

Turbine Meters Technical Data

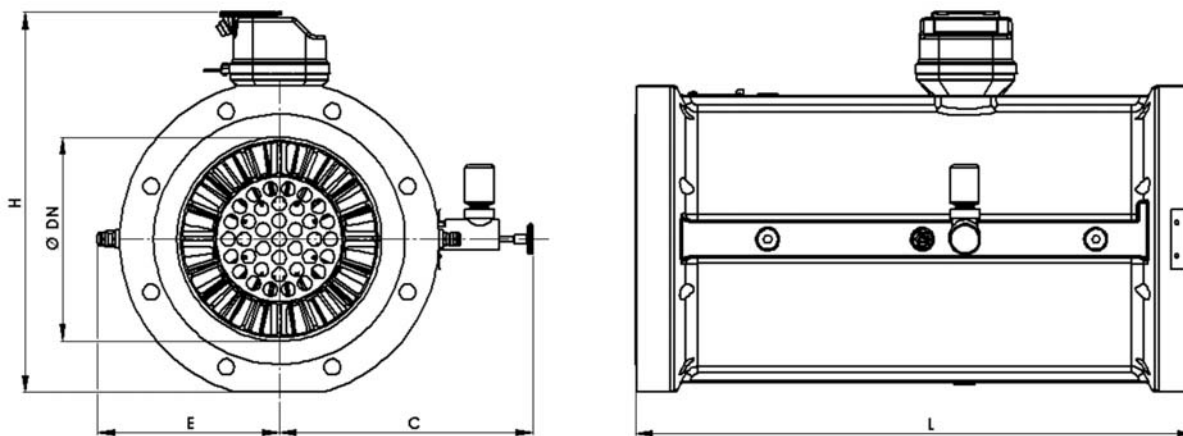

Dimensions

Size	DN	L	C	E	H	Weight		
						AL-150	St-150	St-300-600 ¹
50 mm (2")	50	150	180	100	240	4	10	20
80 mm (3")	80	240	190	115	265	9	28	38
100 mm (4")	100	300	200	125	300	12	35	60
150 mm (6")	150	450	230	155	360	33	85	93
200 mm (8")	200	600	265	175	390	80	125	125
250 mm (10")	250	750	290	205	410	-	150	220
300 mm (12")	300	900	320	235	440	-	180	328

1 AL -> Aluminum Body Turbine meter; St -> Steel Body Turbine meter



Capacity

Size	G-rate ¹	Range Qmin - Q max [m ³ /h]	Pressure Loss (mbar)	Ua Value Tr = [m ³]	LF [pulse/m ³]	HF shaft [Hz] ⁴	HF wheel [Hz] ⁴
50mm (2")	G 40	10 - 65	9.70	0.1	10	250-650	na
	G 65	10 - 100	9.70	0.1	10		
	G 100	8 - 160	16.00	0,1	10		
80mm (3")	G 100	8 - 160	9.70	1	1	250-350	1300-2300
	G 160	13 - 250	9.70	1	1		
	G 250	20 - 400	16.00	1	1		
	G 400	32 - 650	16.00	1	1		
100mm (4")	G 160	13 - 250	6.40	1	1	150-250	1300-1700
	G 250	20 - 400	9.70	1	1		
	G 400	32 - 650	16.00	1	1		
	G 650	50 - 1000	16.00	1	1		
150mm (6")	G 400	32 - 650	9.70	1	1	150-200	1000-1200
	G 650	50 - 1000	9.70	1	1		
	G 1000	80 - 1600	16.00	10	0.1		
	G 1600	125 - 2500	16.00	10	0.1		
200mm (8")	G 650	50 - 1000	6.40	10	0.1	70-150	650-1200
	G 1000	80 - 1600	9.70	10	0.1		
	G 1600	125 - 2500	16.00	10	0.1		
	G 2500	200 - 4000	16.00	10	0.1		
250mm (10")	G 1000	80 - 1600	6.40	10	0.1	70-150	650-1200
	G 1600	125 - 2500	9.70	10	0.1		
	G 2500	200 - 4000	16.00	10	0.1		
300mm (12")	G 1600	125 - 2500	6.40	10	0.1	30-90	250-700
	G 2500	200 - 4000	9.70	10	0.1		
	G4000	320 - 6500	16.00	10	0.1		

- 1) Cast and bare stock meters 4G rates available. Welded housings 3G rates available.
- 2) The table is based on the minimum requirements of EN12261 and with natural gas at atmospheric conditions.
The pressure loss is measured one diameter upstream to one diameter downstream of the meter on straight pipe of the same size as the meter.
- 3) tr = m³ per revolution of the first drum.
- 4) Frequencies in table are indicative

Bolt Configuration

ANSI	Description	Pipe Size (inch)						
		2'	3"	4"	6"	8"	10"	12"
150	Thread (UNC)	5/8	5/8	5/8	3/4	3/4	7/8	7/8
	Thread aluminium screwed	30	34	35	35	40	na	na
	Thread steel screwed	24	29	28	30	45	na	na
	Flange height bolt/nut version	24	23	25	27	28	30	32
	Washer Size	M16	M16	M16	M20	M20	M24	M24
300	Thread (UNC)	5/8	3/4	3/4	3/4	7/8	1	1 1/8
	Thread steel screwed	34	38	na	na	na	na	Na
	Flange height bolt/nut version	na	na	36	42	41	48	51
	Washer Size	M16	M20	M20	M20	M24	M27	M30
600	Thread (UNC)	5/8	3/4	7/8	1	1 1/8	1 1/4	1 1/4
	Thread depth steel bar stock screwed	34	38	na	na	na	na	na
	Flange height (bolt/nut version)	na	na	44	50	56	64	67
	Washer Size	M16	M20	M24	M24	M30	M33	M33

DIN	Description	Pipe Size (mm)						
		50	80	100	150	200	250	300
10	Thread (metric)					20	20	20
	Thread depth (screwed version)					na	na	na
	Flange height (bolt/nut version)		See PN 16			24	26	26
	Washer Size					M20	M20	M20
16	Thread (metric)	16	16	16	20	20	24	24
	Thread depth aluminium screwed	30	34	35	35	40	na	na
	Thread steel screwed	32	29	28	30	45	na	na
	Thread depth steel bar stock trough hole	150	na	na	na	na	na	na
	Flange height (bolt/nut version)	na	23	28	na	24	26	28
Washer Size	M16	M16	M16	M20	M20	M24	M24	
25	Thread (metric)	16	na	16	24	24	27	27
	Thread depth steel bar stock screwed	32	na	na	na	na	na	na
	Thread depth steel bar stock trough hole	150	na	na	na	na	na	na
	Flange height (bolt/nut version)	na	na	35	38	27	29	30
	Washer Size	M16	na	M20	M24	M20	M24	M27
40	Thread (metric)	16	na	20	24	27	30	30
	Thread depth steel bar stock screwed	32	na	na	na	na	na	na
	Thread depth steel bar stock trough hole	150	na	na	na	na	na	na
	Flange height (bolt/nut version)	na	na	35	38	34	38	42
	Washer Size	M16	na	M20	M24	M27	M30	M30
100	Thread (metric)	20	24	27	30	33	36	39
	Thread depth steel bar stock screwed	na	na	na	na	na	na	na
	Flange height (bolt/nut version)	na	na	na	na	52	60	68
	Washer Size	M20	M24	M27	M30	M33	M36	M39

Thread depths and flange heights include raised face and do not include gasket height



GE Oil & Gas
 7051HS Varsseveld
 The Netherlands
 T: +31 (0) 31527 1100
 F: +31 (0) 31527 1105
 Visit us online at:
www.ge-energy.com

2012 General Electric Company
 All Rights Reserved
 * Denotes trademark of
 General Electric Company