

Utility Systems

Product Range
June 2008
Export



+GF+

GEORG FISCHER
PIPING SYSTEMS

General Information

Packaging	GP pcs. pal. kg pal. vol. pal.	Pieces per Bulk Pack pieces per pallet weight per pallet volume per pallet (including pallet)
Measures, units and short cuts	d, d1, d2 DN L, L1, L2 H, H1, H2 e, e1, e2 kg SC AL S SDR	diameter nominal diameter length height wall thickness weight size of bolts number of bolt holes pipe series Standard Dimension Ratio
Working pressure	The pressure rating of Georg Fischer PE-Fittings refers to the calculated values of prEN 12201 and prEN 1555 considering the total security value. National Regulations and standards have to be observed.	
Specification	Georg Fischer Fittings meet the ISO-standards, CEN-standards (respectively draft standards) as well as other national standards.	
Approval	The Georg Fischer products are subjected to extensive internal and external tests and are approved by all major institutes and approval authorities (for example: DVGW, SVGW, KIWA, IIP, Gaz de France, Gas Natural, etc.).	
General Conditions of Supply	Please find the General Conditions of Supply on the last page.	
Works certificates	Works certificates corresponding EN 10204 2.2 will be delivered on request. Works certificates corresponding EN 10204 3.1 B will be delivered on request, we will charge CHF 20.– administrative costs.	
Quality management Environmental management	Quality management system is well established at Georg Fischer and is continuously improved to satisfy our customers. Georg Fischer Piping Systems are certified according to ISO 9001 as well as ISO 14001 (Environmental management).	
Technical documentation	For further technical information we offer you the Georg Fischer “Technical handbook distribution” and the detailed assembly instructions.	
Service, training and consultation	Our comprehensive training program offers you the possibility for extensive advice and training. Please reserve for a our training program for piping systems.	
Your partner	Georg Fischer is a world-wide organisation. Please find the address of your Georg Fischer partner on the cover back.	

Table of Contents

	Page
Electrofusion Couplers	11
Electrofusion Elbows	13
Electrofusion Tees	15
Electrofusion Reducers	17
Transitions	20
<hr/>	
ELGEF Branch Fittings	27
ELGEF Modular System	29
Excess Flow Valves	38
Electrofusion Saddles	41
Tapping Saddles and Valves	43
<hr/>	
PE Ball Valves and POM Service Valves	63
Spigot Fittings	70
Spigot Fittings (short ends)	93
<hr/>	
Hydrants and Hydrant Kits	101
Flanges and Seals	105
<hr/>	
POLY 16 Plus - Fittings	111
POLY 16 Plus - Universal Fittings	134
POLY 16 Plus - Tapping Saddles	136
POLY 16 Plus - Saddles	143
<hr/>	
POLYFAST AZ - Fittings	149
POLYFAST AZ - Saddles	156
<hr/>	
PRIMOFIT	157
<hr/>	
Index	165
<hr/>	

Modular system ELGEF® Plus

Less stock, higher flexibility, more variations – a contradiction? Not with the ELGEF Plus modular system. It is that easy:

Modular System Saddles

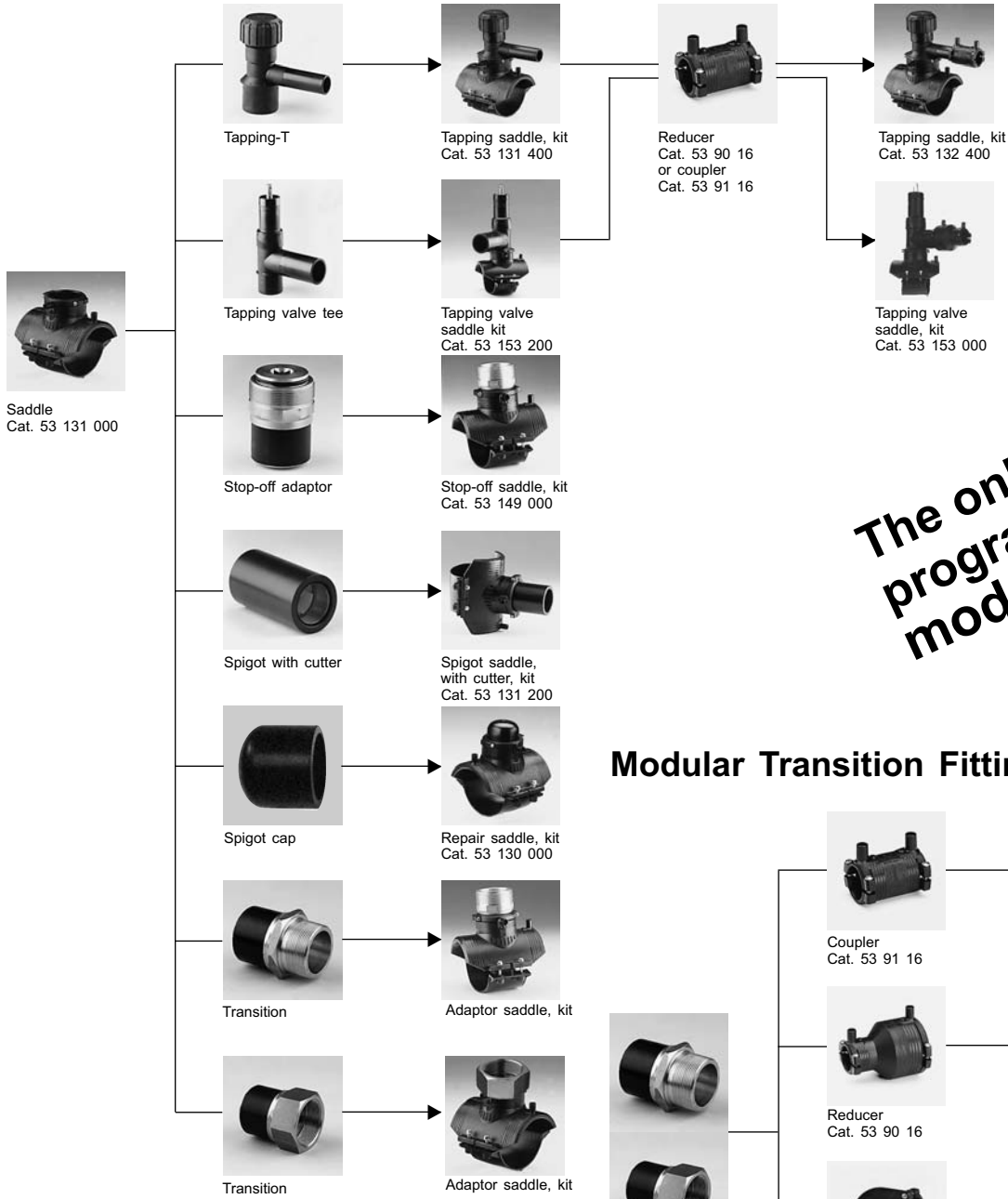

The only programme with a modular system

Modular Transition Fitting System

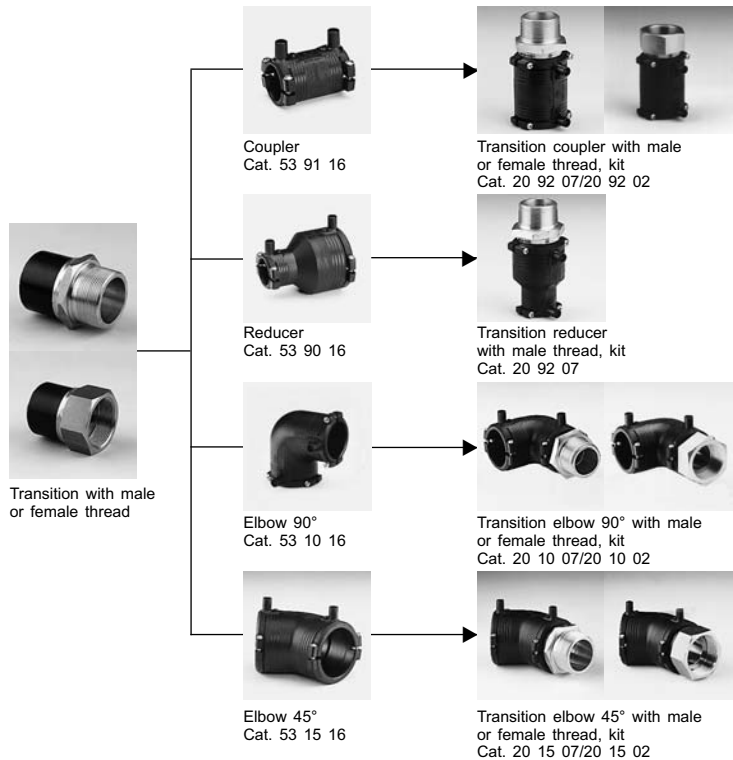

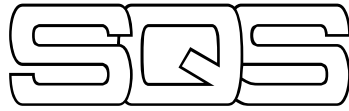

The Swiss Association for Quality and Management Systems

SQS herewith certifies that the company named below has a management system which meets the requirements of the normative bases specified below.

Georg Fischer Piping Systems Ltd. CH-8201 Schaffhausen

Certified area

**Georg Fischer Piping Systems Ltd., Schaffhausen
Georg Fischer Rohrleitungssysteme (Schweiz) AG, Sales Company
Georg Fischer Wavin Ltd., Schaffhausen and Subingen
Georg Fischer Building Technology Ltd., Schaffhausen**

Field of activity

The Piping Systems Group develops, manufactures and distributes plastic or metal components and systems for conducting, pumping, controlling, measuring and regulating liquids and gases and to this end provides comprehensive engineering and related services

Based on the audit result, SQS issues the

SQS Certificate ISO 9001:2000 / ISO 14001:2004

CH-3052 Zollikofen, May 28, 2006

This SQS Certificate is valid up to and including May 27, 2009

Scope number 14

Registration number 10684

President SQS

Managing Director SQS

X. Edelmann

T. Zahner



SCES 002, 023



ELGEF Plus APPROVALS



Certification body	Certificate number	Material	Product range	Country
DGS	04 MAT.PA 002	PE 100	Electrofusion couplers	France
DGS	04 MAT.PA 010	PE 100	Fittings, Spigot	France
DIBt	Z-40.23-282	PE 100, PE 80	Electrofusion couplers, Fittings, Butt Fusion - Transition, Fittings, Butt fusion, mm, Fittings, Socket fusion - Transition, Fittings, Socket fusion, mm, Union, Butt Fusion, Union, Socket Fusion	Germany
DIBt	Z-40.23-282	PE 100, PE 80	Electrofusion couplers, Fittings, Butt Fusion - Transition, Fittings, Butt fusion, mm, Fittings, Socket fusion - Transition, Fittings, Socket fusion, mm, Union, Butt Fusion, Union, Socket Fusion	Germany
DS	1594-A	PE 100	Electrofusion couplers, Electrofusion fittings, Electrofusion fittings, Electrofusion saddles	Denmark
DVGW	DV-8611AS2072 (GF)	PE 100	Electrofusion tapping valves	Germany
DVGW	DV-8601AQ3257 (8601)	PE 100, PE 100/Brass, PE 100/Steel, PE 80	Electrofusion couplers, Electrofusion fittings, Electrofusion saddles, Fittings, Spigot, Fittings, Transition	Germany
DVGW	DV-8606AQ3258 (8606)	PE 100, PE 100/Brass, PE 100/Steel, PE 80	Electrofusion branch fitting, Electrofusion couplers, Electrofusion fittings, Electrofusion saddles, Fittings, Spigot, Fittings, Transition	Germany
DVGW	DV-8611AQ3259 (8611)	PE 100, PE 80	Electrofusion branch fitting, Electrofusion couplers, Electrofusion fittings, Electrofusion saddles, Fittings, Spigot	Germany
ETI	2-8-7/58	PE 100, PE 100/Brass, PE 80	Electrofusion couplers, Electrofusion fittings, Electrofusion saddles, Fittings, Spigot, Fittings, Transition, Valves	Estonia
GdF	2002-082/AD	PE 100	Electrofusion fittings	France
GdF	2002-083/AD	PE 100	Fittings, Spigot	France
GdF	2003-033/PH	PE 100	Electrofusion couplers	France
GdF	2003-034/PH	PE 100	Electrofusion saddles	France
GdF	2004-081/AD	PE 100	Electrofusion saddles	France
GdF	95/020-AD	PE 100	Electrofusion couplers	France
GdF	95/052-AD	PE 100	Electrofusion couplers	France
GdF	BTR	PE 100	Valves, plug	France
GdF	PRISES SDG	PE 100	Electrofusion saddles	France





Certification body	Certificate number	Material	Product range	Country
ITC	05 0286 V/AO 05 0287 V/AO	PE 100	Electrofusion couplers, Electrofusion fittings, Electrofusion saddles, Fittings, Spigot	Czech Republic
MHEW	Water 2004	Machine, PE 100, PE 80	Electrofusion branch fitting, Electrofusion control units, Electrofusion couplers, Electrofusion fittings, Electrofusion saddles, Fittings, Butt fusion, mm	Oman
NIGC	Certificate acc IGS-MS-PL-014 part 2	PE 100	Electrofusion couplers, Electrofusion fittings, Electrofusion saddles, Fittings, Spigot	Iran
ON	ON-N 2005 120 ... 130	PE 100, PE 100/Steel	Electrofusion branch fitting, Electrofusion couplers, Electrofusion fittings, Electrofusion saddles, Electrofusion tapping valves, Fittings, Spigot, Fittings, Transition	Austria
ÖVGW	G 1.321	PE 100, PE 80	Electrofusion branch fitting, Electrofusion couplers, Electrofusion fittings, Electrofusion saddles, Electrofusion tapping valves, Fittings, Socket fusion, mm, Fittings, Spigot	Austria
ÖVGW	G 2.450	PE 100/Steel	Fittings, Transition	Austria
ÖVGW	W 1.229	PE 100, PE 100/Brass, PE 100/Steel, PE 80	Electrofusion branch fitting, Electrofusion couplers, Electrofusion fittings, Electrofusion saddles, Electrofusion tapping valves, Fittings, Socket fusion, mm, Fittings, Spigot, Fittings, Transition	Austria
PROMNAZOR	7/727-1140	PE 100, PE 80	Electrofusion couplers, Electrofusion saddles, Fittings, Spigot	Kasastan
SVGW	G 02-014-9	PE 100, PE 100/Steel, PE 80	Electrofusion branch fitting, Electrofusion couplers, Electrofusion fittings, Electrofusion saddles, Electrofusion tapping valves, Fittings, Spigot, Fittings, Transition	Switzerland
SVGW	W 9506-K 192	PE 100, PE 100/Brass, PE 100/Steel, PE 80	Electrofusion branch fitting, Electrofusion couplers, Electrofusion fittings, Electrofusion saddles, Electrofusion tapping valves, Fittings, Spigot, Fittings, Transition	Switzerland
WBS	9901515	PE 100	Fittings	United Kingdom
WIS	Test Report acc WIS 4-32-14 Section 7.9	PE 100	Electrofusion couplers	United Kingdom



**ELGEF® Plus
Electrofusion System**

ELGEF Plus Couplers
ELGEF Plus Electrofusion
ELGEF Plus Transition Fittings

ELGEF Plus assembly instructions for sockets, fittings and transition adaptors

Sequence of tasks	End Caps d20-d63	End Caps d75-d225	Transition Adaptor d20-d63	Transition Adaptor (loose nut) d20-d63
				
1 Rough clean pipe(s), cut at right angles and deburr.	+	+	+	+
2 Remove oxidised layer on pipe(s) with peeling tool	+	+	O difficult assembly conditions	O difficult assembly conditions
3 Clean pipe(s) in fusion zone with Tangit cleaning cloth or Tangit PE cleaner	+	+	+	+
4 Mark insertion depth ¹ on the pipe	O	O	-	-
5 Remove fitting(s) from the bag without touching the fusion surface(s)	+	+	+	+
6 Screw or unscrew transition adaptor	-	-	+	O
7 Push pipe into socket up to centre stop or marking	+	+	-	-
8 Alternately, tighten integrated pipe clamp screws	+	-	-	-
9 Mount and tighten pipe clamp (if joint is under stress)	-	+	-	-
10 Push second pipe up to centre stop or marking	-	-	+	+
11 Alternately, tighten integrated pipe clamp screws	-	-	+	+
12 Mount and fix pipe clamp (if joint is under stress)	-	+	-	-
13 Complete fusion procedure in accordance with operating instructions for unit	+	+	+	+
14 After fusion, check indicators on fitting and the display in fusion control unit, then remove cables	+	+	+	+
15 Wait for cooling time ² , then remove pipe clamp if used	-	+	-	-
16 Screw or unscrew transition adaptor with loose nut (if used)	-	-	-	O
17 Wait for the minimum cooling time ² and conduct pressure test	+	+	+	+



When using oval pipes, re-rounding clamps should be mounted on both sides of the fitting to be fused.

+ = compulsory
O = optional
- = unnecessary

Distribution

Application technology PE Assembly and operating instructions

Overview ELGEF® Plus couplers, fittings and transition adaptors

¹ Insertion depth for couplers and fittings

d [mm]	Insertion depth L1 [mm]	
	SDR11	SDR17
20	34	
25	34	
32	36	
40	40	
50	44	
63	48	
75	55	
90	62	
110	72	
125	79	
140	84	
160		90
180		95
200		101
225		110
250		122
280		126
315		132
355		122
400		122
450		145
500		145
560		196
630		221

² Minimum cooling time for couplers and fittings in minutes

d [mm]	SDR	Removal of clamp [min.]	Pressure test	
			p ≤ 6 bar [min.]	p ≤ 24 bar [min.]
20-63	11	6	10	30
75-110	11	10	20	60
125-160	11	15	30	75
180-225	11	20	45	90
250-400	11	30	60	150

p = test pressure

d [mm]	SDR	Removal of clamp [min.]	Pressure test	
			p ≤ 6 bar [min.]	p ≤ 24 bar [min.]
125-160	17	15	30	75
180-225	17	20	45	90
250-400	17	30	60	150
450-500	17	40	60	150
560-630	17	60	60	150

p = test pressure

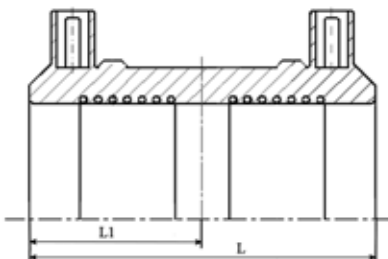

ELGEF® Plus Electrofusion Fittings

53 91 16

Coupler with integral pipe fixation

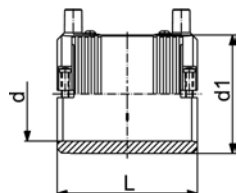

PF 2 51 312 001

- PE 100 SDR 11 (ISO S5)
- 10 bar Gas / 16 bar Water
- 4 mm pin connectors
- Limited path fusion indicators
- Removable centre stop

d [mm]	Code	GP	kg	d1 [mm]	L [mm]	z [mm]
20	753 911 606	50	0.054	31	68	2
25	753 911 607	50	0.060	36	68	2
32	753 911 608	50	0.072	44	72	2
40	753 911 609	50	0.100	54	80	2
50	753 911 610	10	0.136	66	88	2
63	753 911 611	10	0.194	81	96	2

53 91 16

Coupler

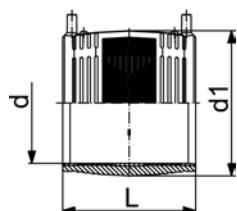

PF 2 51 312 002

- PE 100 SDR 11 (ISO S5)
- 10 bar Gas / 16 bar Water
- 4 mm pin connectors
- Limited path fusion indicators
- Removable centre stop up to d160

d [mm]	Code	GP	kg	d1 [mm]	L [mm]	z [mm]
75	753 911 612	12	0.287	96	110	2
90	753 911 613	10	0.421	113	125	2
110	753 911 614	5	0.697	138	145	2
125	753 911 615	5	0.738	154	158	3
140	753 911 616	5	0.968	172	168	3
160	753 911 617	6	1.390	196	180	3
180	753 911 618	5	1.750	219	194	
200	753 911 619	2	2.350	244	208	
225	753 911 620	3	3.193	273	224	
250	753 911 621	2	4.210	304	244	
280	753 911 622	1	5.675	340	252	
315	753 911 623	1	8.000	382	268	
355	753 911 624	1	12.110	432	246	
400	753 911 625	1	15.993	487	246	

53 91 18

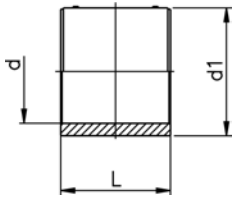

PF 2 51 312 002

Coupler

- PE 100 SDR 17 (ISO S8)
- 5 bar Gas / 10 bar Water
- 4 mm pin connectors
- Limited path fusion indicators
- d160 with removable centre stop

d [mm]	Code	GP	kg	d1 [mm]	L [mm]
160	753 911 817	6	1.050	186	180
180	753 911 818	4	1.450	213	194
200	753 911 819	2	1.800	233	208
225	753 911 820	3	2.385	261	224
250	753 911 821	2	4.345	304	244
280	753 911 822	1	5.675	340	252
315	753 911 823	1	8.000	382	268
355	753 911 824	1	8.200	414	246
400	753 911 825	1	15.993	487	246
450	753 911 826	1	15.500	522	290
500	753 911 827	1	19.000	579	290

53 91 18

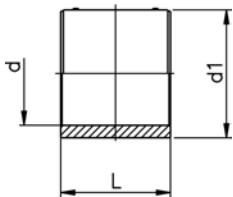

PF 2 51 312 002

Coupler

- PE 100 SDR 17 (ISO S8)
- 5 bar Gas / 10 bar Water
- 4 mm pin connectors
- Limited path fusion indicators
- 2 separate welding zones
- **Installation only with pressure pad kit (799 301 561)**
- Standard welding units required with steady output power of 2500 W
- For generator use: output power of min. 5 kW recommended

d [mm]	Code	GP	kg	d1 [mm]	L [mm]
560	753 911 828	1	25.500	638	392
630	753 911 829	1	35.000	716	442

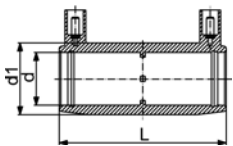

PF 2 51 312 008

Coupler long

- PE 100 SDR 11 (ISO S5)
- 10 bar Gas / 16 bar Water
- 4 mm pin connectors
- Removable centre stop

d [mm]	Code	GP	kg	d1 [mm]	L [mm]	z [mm]
32	753 911 208	288	0.084	44	104	2
40	753 911 209	128	0.135	56	121	2
50	753 911 210	96	0.215	68	139	2
63	753 911 211	48	0.318	82	166	2

53 10 16

Elbow 90° with integral pipe fixation



- PE 100 SDR 11 (ISO S5)
- 10 bar Gas / 16 bar Water
- 4 mm pin connectors
- Limited path fusion indicators

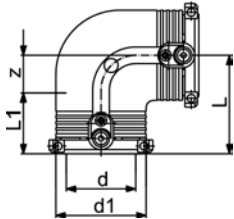

PF 2 51 314 001

d [mm]	Code	GP	kg	d1 [mm]	L [mm]	L1 [mm]	z [mm]
20	753 101 606	10	0.093	35	54	34	20
25	753 101 607	10	0.078	35	54	34	20
32	753 101 608	10	0.098	44	53	36	17
40	753 101 609	10	0.142	54	62	39	23
50	753 101 610	10	0.215	66	71	43	28
63	753 101 611	10	0.280	81	81	48	32

53 10 18

Elbow 90°



- PE 100 SDR 11 (ISO S5)
- 10 bar Gas / 16 bar Water
- 4 mm pin connectors
- Limited path fusion indicators

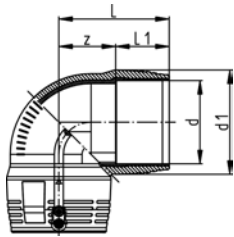

PF 2 51 314 001

d [mm]	Code	GP	kg	d1 [mm]	L [mm]	L1 [mm]	z [mm]
75	753 101 812	33	0.530	97	101	61	40
90	753 101 813	14	0.676	115	122	62	60
110	753 101 814	10	1.190	140	147	72	76
125	753 101 815	5	1.740	151	142	74	68
160	753 101 817	4	3.433	196	178	92	86
180	753 101 818	1	4.286	219	195	95	100

53 10 18

Elbow 90°



- PE 100 SDR 11 (ISO S5)
- 10 bar Gas / 16 bar Water
- 4 mm pin connectors
- Limited path fusion indicators
- Two separate fusion zones

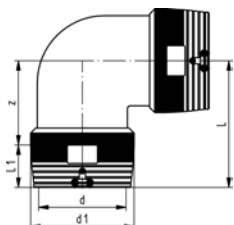

PF 2 51 314 007

d [mm]	Code	GP	kg	d1 [mm]	L [mm]	L1 [mm]	z [mm]
200	753 101 819	1	8.173	245	265	104	161
225	753 101 820	1	12.440	274	305	112	193
250	753 101 821	1	15.800	305	335	123	212

53 15 16

Elbow 45° with integral pipe fixation

- PE 100 SDR 11 (ISO S5)
- 10 bar Gas / 16 bar Water
- 4 mm pin connectors
- Limited path fusion indicators

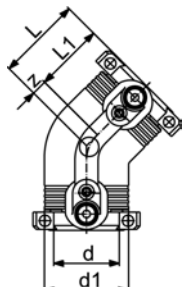

PF 2 51 314 001

d [mm]	Code	GP	kg	d1 [mm]	L [mm]	L1 [mm]	z [mm]
32	753 151 608	20	0.087	44	44	36	8
40	753 151 609	10	0.121	54	50	39	11
50	753 151 610	10	0.140	66	56	43	13
63	753 151 611	10	0.274	81	63	48	15

53 15 18

Elbow 45°

- PE 100 SDR 11 (ISO S5)
- 10 bar Gas / 16 bar Water
- 4 mm pin connectors
- Limited path fusion indicators

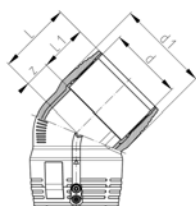

PF 2 51 314 001

d [mm]	Code	GP	kg	d1 [mm]	L [mm]	L1 [mm]	z [mm]
75	753 151 812	-	0.437	97	79	62	17
90	753 151 813	20	0.537	115	91	62	29
110	753 151 814	6	0.974	140	112	72	40
125	753 151 815	6	1.420	160	127	78	49
160	753 151 817	5	1.800	196	134	92	42
180	753 151 818	1	3.200	217	142	95	47

53 15 18

Elbow 45°

- PE 100 SDR 11 (ISO S5)
- 10 bar Gas / 16 bar Water
- 4 mm pin connectors
- Limited path fusion indicators
- Two separate fusion zones

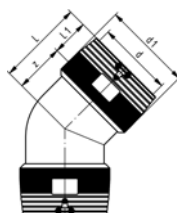

PF 2 51 314 007

d [mm]	Code	GP	kg	d1 [mm]	L [mm]	L1 [mm]	z [mm]
200	753 151 819	1	6.810	245	215	104	111
225	753 151 820	1	10.590	274	235	112	123
250	753 151 821	1	12.740	305	263	123	140

53 21 16

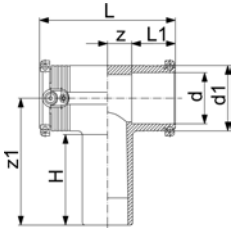

PF 2 51 314 001

Tee 90°, equal with integral pipe fixation

- PE 100 SDR 11 (ISO S5)
- 10 bar Gas / 16 bar Water
- 4 mm pin connectors
- Limited path fusion indicators

d [mm]	Code	GP	kg	d1 [mm]	L [mm]	L1 [mm]	z [mm]	z1 [mm]	H [mm]
20	753 211 606	10	0.100	35	90	34	11	92	67
25	753 211 607	10	0.088	35	90	34	11	92	70
32	753 211 608	10	0.115	44	102	36	15	100	74
40	753 211 609	10	0.176	54	120	39	21	114	82
50	753 211 610	5	0.268	66	135	43	24	126	90
63	753 211 611	5	0.429	81	152	48	28	150	102

53 20 18

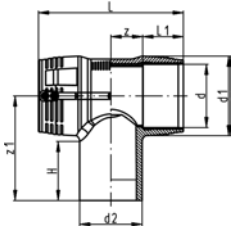

PF 2 51 314 001

Tee 90° equal

- PE 100 SDR 11 (ISO S5)
- 10 bar Gas / 16 bar Water
- 4 mm pin connectors
- Limited path fusion indicators

d [mm]	Code	GP	kg	d1 [mm]	L [mm]	L1 [mm]	z [mm]	z1 [mm]	H [mm]
75	753 201 812	-	0.597	97	187	61	33	126	78
90	753 201 813	10	0.910	115	205	62	41	161	94
110	753 201 814	5	1.420	140	255	72	56	184	104
125	753 201 815	4	1.980	151	256	75	53	174	92
160	753 201 817	3	4.893	196	325	92	71	206	103
180	753 201 818	2	6.770	225	344	90	82	250	110

53 20 18

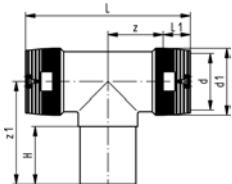

PF 2 51 314 007

Tee 90°, equal

- PE 100 SDR 11 (ISO S5)
- 10 bar Gas / 16 bar Water
- 4 mm pin connectors
- Limited path fusion indicators
- Two separate fusion zones

d [mm]	Code	GP	kg	d1 [mm]	L [mm]	L1 [mm]	z [mm]	z1 [mm]	H [mm]
200	753 201 819	1	10.100	245	560	104	176	250	117
225	753 201 820	1	15.145	274	610	112	193	270	122
250	753 201 821	1	18.100	305	667	123	211	288	127

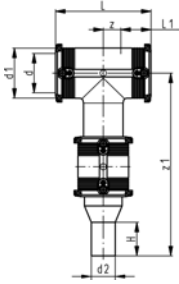

Tee 90°, reduced (Kit)

- PE 100 SDR 11 (ISO S5)
- 10 bar Gas / 16 bar Water
- Integral pipe fixation (up to d63)
- 4 mm pin connectors
- Limited path fusion indicators
- Supplied as kit including ELGEF® Plus Coupler and Spigot Reducer

d [mm]	d2 [mm]	Code	kg	d1 [mm]	L [mm]	L1 [mm]	z [mm]	z1 [mm]	H [mm]
40	20	193 281 004	0.314	54	120	39	21	244	212
40	25	193 281 005	0.319	54	120	39	21	244	212
75	40	193 280 998	1.060	97	187	61	33	296	248
90	50	193 280 999	1.620	112	202	61	41	336	274
110	63	193 280 961	2.670	136	242	65	56	366	293
125	63	193 280 963	3.690	151	256	75	53	361	279
125	110	193 280 965	3.920	151	256	75	53	389	307
160	125	193 280 969	8.250	196	325	92	71	451	348
180	90	193 281 032	10.056	225	344	90	82	487	347
180	110	193 281 033	10.246	225	344	90	82	495	355

PF 2 51 314 001

53 21 10

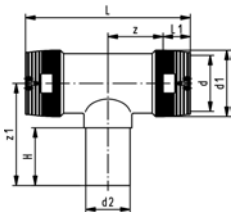

Tee 90°, reduced

- PE 100 SDR 11 (ISO S5)
- 10 bar Gas / 16 bar Water
- 4 mm pin connectors
- Limited path fusion indicators
- Two separate fusion zones
- *Two connected fusion zones

d [mm]	d2 [mm]	Code	GP	kg	d1 [mm]	L [mm]	L1 [mm]	z [mm]	z1 [mm]	H [mm]
160	63	753 211 037	2	4.940	196	405	90	113	176	65
160	90	753 211 039	2	5.040	196	405	90	113	188	79
160	110	753 211 040	2	5.160	196	405	90	113	195	85
200	90	753 211 059	1	11.260	245	557	104	175	215	81
200	110	753 211 060	-	11.260	245	557	104	175	218	84
200	160	753 211 063	-	11.260	245	557	104	175	236	101
225	90	753 211 069	1	12.700	274	615	112	196	226	80
225	110	753 211 070	1	12.750	274	615	112	196	235	85
225	160	753 211 073	1	13.200	274	615	112	196	255	105
250	110	753 211 080	-	11.260	305	668	123	211	245	85
250	160	753 211 083	-	11.260	305	668	123	211	264	101

PF 2 51 314 001

53 20 16

Tee 90° with weldable outlet (Kit) equal or reduced

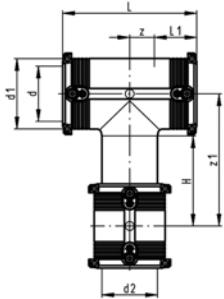

- PE 100 SDR 11 (ISO S5)
- 10 bar Gas / 16 bar Water
- Integral pipe fixation (up to d63)
- 4 mm pin connectors
- Limited path fusion indicators
- Supplied as kit including ELGEF® Plus Coupler or ELGEF® Plus Reducer

d [mm]	d2 [mm]	Code	GP	kg	d1 [mm]	L [mm]	L1 [mm]	z [mm]	z1 [mm]	H [mm]
20	20	753 201 606	6	0.170	35	90	34	11	92	67
25	25	753 201 607	6	0.170	35	90	34	11	92	70
32	32	753 201 608	8	0.213	44	102	36	15	100	74
40	32	193 281 006	-	0.248	54	120	39	21	127	95
40	40	753 201 609	5	0.295	54	120	39	21	114	82
50	32	193 281 007	4	0.364	66	135	43	24	144	108
50	40	193 281 008	4	0.404	66	135	43	24	140	104
50	50	753 201 610	4	0.419	66	135	43	24	126	90
63	32	193 280 997	4	0.550	81	152	48	28	173	125
63	40	193 281 009	4	0.605	81	152	48	28	169	121
63	50	193 281 010	4	0.618	81	152	48	28	165	117
63	63	753 201 611	4	0.641	81	152	48	28	150	102
90	63	193 281 011	3	1.300	112	202	61	41	182	120
90	90	753 201 613	3	1.450	112	202	61	41	146	84
110	90	193 281 012	2	2.294	136	242	65	56	200	127
110	110	753 201 614	2	2.400	136	242	65	56	161	88
125	90	193 281 013	-	2.850	151	256	75	53	214	132
125	125	753 201 615	1	2.930	151	256	75	53	174	92
160	110	193 281 030	-	6.093	196	325	92	71	271	168
160	160	753 201 617	1	6.664	196	325	92	71	206	103
180	125	193 281 031	-	8.770	225	344	90	82	330	190
180	180	753 201 618	1	9.600	225	344	90	82	250	110

PF 2 51 314 001

53 90 16

Reducer with integral pipe fixation

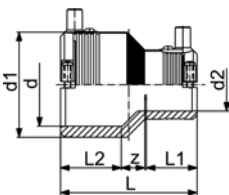

- PE 100 SDR 11 (ISO S5)
- 10 bar Gas / 16 bar Water
- 4 mm pin connectors
- Limited path fusion indicators

d [mm]	d2 [mm]	Code	GP	kg	d1 [mm]	L [mm]	L1 [mm]	L2 [mm]	z [mm]
25	20	753 901 639	20	0.059	35	74	34	34	6
32	20	753 901 640	20	0.071	44	79	33	36	10
32	25	753 901 641	20	0.060	44	79	33	36	10
40	20	753 901 644	20	0.069	54	88	33	39	15
40	25	753 901 645	20	0.071	54	88	33	39	15
40	32	753 901 646	20	0.072	54	88	33	39	13
50	32	753 901 651	10	0.096	66	96	35	43	18
50	40	753 901 652	15	0.136	66	96	39	43	14
63	32	753 901 656	10	0.171	81	106	35	48	23
63	40	753 901 657	10	0.176	81	106	39	48	19
63	50	753 901 658	10	0.189	81	106	43	48	15

PF 2 51 314 001

53 90 18

Reducer

- PE 100 SDR 11 (ISO S5)
- 10 bar Gas / 16 bar Water
- 4 mm pin connectors
- Limited path fusion indicators

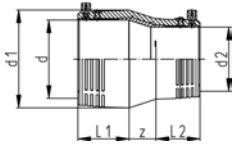

PF 2 51 314 001

d [mm]	d2 [mm]	Code	GP	kg	d1 [mm]	L [mm]	L1 [mm]	L2 [mm]	z [mm]
90	63	753 901 831	12	0.360	113	146	63	47	36
110	90	753 901 833	16	0.657	138	173	73	63	38
125	90	753 901 836	6	0.870	152	180	79	61	40
160	110	753 901 834	5	1.200	196	226	91	70	65
180	125	753 901 835	4	2.000	220	247	97	70	80

53 90 18

Reducer

- PE 100 SDR 11 (ISO S5)
- 10 bar Gas / 16 bar Water
- 4 mm pin connectors
- Limited path fusion indicators
- Two separate fusion zones

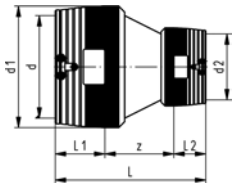

PF 2 51 314 007

d [mm]	d2 [mm]	Code	GP	kg	d1 [mm]	L [mm]	L1 [mm]	L2 [mm]	z [mm]
200	160	753 901 837	1	4.150	245	311	104	90	117
225	160	753 901 838	1	5.240	274	331	112	90	129
250	160	753 901 840	2	7.100	305	362	123	90	149
250	200	753 901 841	2	7.680	305	380	123	104	153

93 28 09

Reducer (Kit)

- PE 100 SDR 11 (ISO S5)
- 10 bar Gas / 16 bar Water
- Integral pipe fixation (up to d63)
- 4 mm pin connectors
- Limited path fusion indicators
- Supplied as kit including ELGEF® Plus Coupler and Spigot Reducer

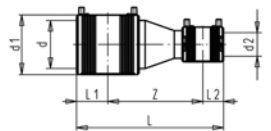

PF 2 51 314 001

d [mm]	d2 [mm]	Code	kg	d1 [mm]	L [mm]	L1 [mm]	L2 [mm]	z [mm]
75	40	193 280 992	0.567	96	265	55	40	170
75	50	193 280 993	0.610	96	269	55	44	170
75	63	193 280 994	0.700	96	273	55	48	170
90	50	193 280 958	0.848	113	297	63	44	190
90	75	193 280 995	1.070	113	308	63	55	190
110	63	193 280 950	1.490	138	326	73	48	205
110	75	193 280 996	1.480	138	333	73	55	205
125	63	193 280 953	1.580	154	314	79	48	187
125	110	193 280 951	2.360	154	367	79	73	215
160	90	193 280 954	3.060	196	370	90	63	217
160	125	193 280 952	3.680	196	414	90	79	245
180	110	193 280 959	4.167	214	413	95	73	245

53 96 16

End Cap with integral pipe fixation

- PE 100 SDR 11 (ISO S5)
- 10 bar Gas / 16 bar Water
- 4 mm pin connectors
- Limited path fusion indicators

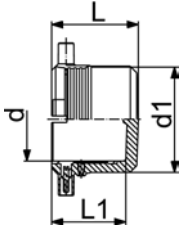

PF 2 51 314 001

d [mm]	Code	GP	kg	d1 [mm]	L [mm]	L1 [mm]
20	753 961 606	50	0.038	35	52	44
25	753 961 607	50	0.030	35	52	44
32	753 961 608	50	0.080	44	52	44
40	753 961 609	50	0.074	54	56	47
50	753 961 610	10	0.086	66	60	49
63	753 961 611	10	0.154	81	66	54

53 96 16

End Cap

- PE 100 SDR 11 (ISO S5)
- 10 bar Gas / 16 bar Water
- 4 mm pin connectors
- Limited path fusion indicators

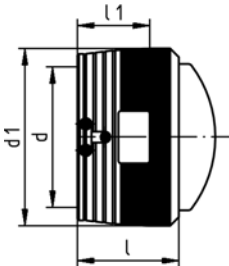

PF 2 51 314 001

d [mm]	Code	GP	kg	d1 [mm]	L [mm]	L1 [mm]
160	753 961 617	2	1.840	196	129	90
200	753 961 619	2	3.040	245	147	104
225	753 961 620	4	4.140	274	157	112
250	753 961 621	1	5.860	305	173	123

53 96 17

End cap (Kit)

- PE 100 SDR 11 (ISO S5)
- 10 bar Gas / 16 bar Water
- 4 mm pin connectors
- Limited path fusion indicators
- Supplied as kit including ELGEF® Plus Coupler
- * Article to be discontinued, replaced by 53 96 16

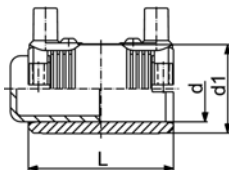

PF 2 51 314 001

d [mm]	Code	GP	kg	d1 [mm]	L [mm]
75	753 961 712	6	0.446	96	110
90	753 961 713	5	0.680	113	125
110	753 961 714	3	1.126	133	145
125	753 961 715	3	1.594	155	158
140	753 961 716	3	2.250	175	170
*160	753 961 717	1	2.712	197	180
180	753 961 718	1	4.136	220	194
*200	753 961 719	1	4.906	245	208
*225	753 961 720	1	6.500	296	224

20 92 07

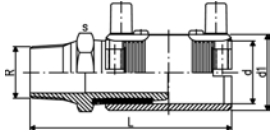

Transition Coupler PE/brass (Ms 58) Male Thread

- PE 100 SDR 11 (ISO S5)
- 10 bar Gas / 16 bar Water
- With integral pipe fixation
- 4 mm pin connectors
- Limited path fusion indicators
- Supplied as kit

d [mm]	R [inch]	Code	GP	kg	d1 [mm]	L [mm]	s [mm]
20	½	720 920 756	6	0.217	31	110	30
20	1	720 920 754	6	0.344	44	124	40
25	¾	720 920 757	6	0.280	36	111	35
25	1	720 920 763	6	0.364	44	124	40
32	½	720 920 764	6	0.235	44	121	30
32	¾	720 920 765	6	0.287	44	122	35
32	1	720 920 758	6	0.355	44	117	40
32	1 ¼	720 920 766	6	0.543	54	135	50
32	1 ½	720 920 767	6	0.685	60	143	60
32	2	720 920 768	6	1.000	81	157	70
40	1	720 920 771	6	0.387	54	133	40
40	1 ¼	720 920 759	6	0.541	54	127	50
40	1 ½	720 920 772	3	0.694	66	143	60
40	2	720 920 773	3	0.992	81	157	70
50	1	720 920 776	6	0.416	66	141	40
50	1 ¼	720 920 777	3	0.578	66	143	50
50	1 ½	720 920 760	6	0.670	66	135	60
50	2	720 920 778	3	0.994	81	157	70
63	1	720 920 781	3	0.460	81	151	40
63	1 ¼	720 920 782	3	0.626	81	153	40
63	1 ½	720 920 783	3	0.741	81	153	60
63	2	720 920 761	4	1.005	81	147	70

PF 2 51 314 002

20 92 02

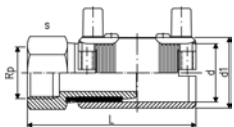

Transition Coupler PE/brass (Ms 58) Female Thread

- PE 100 SDR 11 (ISO S5)
- 10 bar Gas / 16 bar Water
- With integral pipe fixation
- 4 mm pin connectors
- Limited path fusion indicators
- Supplied as kit

d [mm]	Rp [inch]	Code	GP	kg	d1 [mm]	L [mm]	s [mm]
32	1	720 920 258	6	0.338	44	108	40
40	1 ¼	720 920 259	6	0.511	54	118	50
50	1 ½	720 920 260	6	0.744	66	126	60
63	1	720 920 281	3	1.280	81	138	70
63	1 ¼	720 920 282	3	1.230	81	138	70
63	1 ½	720 920 283	3	1.115	81	138	70
63	2	720 920 261	3	1.016	81	138	70

PF 2 51 314 002

20 10 07

Transition Elbow 90° PE/brass (Ms 58) Male Thread

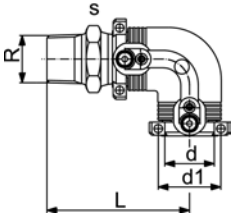

- PE 100 SDR 11 (ISO S5)
- 10 bar Gas / 16 bar Water
- With integral pipe fixation
- 4 mm pin connectors
- Limited path fusion indicators
- Supplied as kit

d [mm]	R [inch]	Code	GP	kg	d1 [mm]	L [mm]	s [mm]
20	½	720 100 756	6	0.240	31	96	30
25	¾	720 100 757	6	0.260	36	97	35
32	1	720 100 758	6	0.383	44	98	40
32	1 ¼	720 100 766	6	0.500	44	100	50
32	1 ½	720 100 767	6	0.562	44	100	60
40	1	720 100 771	6	0.528	54	107	50
40	1 ¼	720 100 759	6	0.584	54	109	50
40	1 ½	720 100 772	6	0.642	54	109	60
50	1	720 100 776	6	0.710	66	116	60
50	1 ¼	720 100 777	6	0.771	66	118	60
50	1 ½	720 100 760	6	0.757	66	118	60
63	1 ¼	720 100 782	3	1.040	81	128	70
63	1 ½	720 100 783	3	1.045	81	128	70
63	2	720 100 761	3	1.115	81	132	70

PF 2 51 314 002

20 10 02

Transition Elbow 90° PE/brass (Ms 58) Female Thread

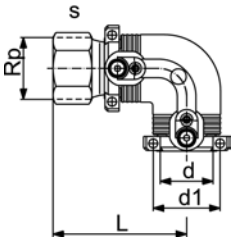

- PE 100 SDR 11 (ISO S5)
- 10 bar Gas / 16 bar Water
- With integral pipe fixation
- 4 mm pin connectors
- Limited path fusion indicators
- Supplied as kit

d [mm]	Rp [inch]	Code	GP	kg	d1 [mm]	L [mm]	s [mm]
32	1	720 100 258	6	0.365	44	89	40
40	1 ¼	720 100 259	6	0.556	54	100	50
50	1 ½	720 100 260	6	0.819	66	109	60
63	1	720 100 281	3	1.420	81	123	70
63	1 ¼	720 100 282	3	1.380	81	123	70
63	1 ½	720 100 283	3	1.305	81	123	70
63	2	720 100 261	3	1.165	81	123	70

PF 2 51 314 002

20 15 07

Transition Elbow 45° PE/brass (Ms 58) Male Thread

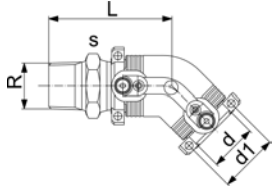

- PE 100 SDR 11 (ISO S5)
- 10 bar Gas / 16 bar Water
- With integral pipe fixation
- 4 mm pin connectors
- Limited path fusion indicators
- Supplied as kit

d [mm]	R [inch]	Code	GP	kg	d1 [mm]	L [mm]	s [mm]
32	1	720 150 758	6	0.374	44	89	40
32	1 ¼	720 150 766	6	0.380	44	91	50
32	1 ½	720 150 767	6	0.560	44	91	60
40	1	720 150 771	1	0.510	54	95	50
40	1 ¼	720 150 759	6	0.560	54	97	50
40	1 ½	720 150 772	1	0.630	54	97	60
50	1	720 150 776	1	0.670	66	101	60
50	1 ¼	720 150 777	1	0.740	66	103	60
50	1 ½	720 150 760	6	0.720	66	103	60
63	1 ¼	720 150 782	3	0.990	81	110	70
63	1 ½	720 150 783	3	0.990	81	110	70
63	2	720 150 761	3	1.069	81	114	70

PF 2 51 314 002

20 15 02

Transition Elbow 45° PE/brass (Ms 58) Female Thread

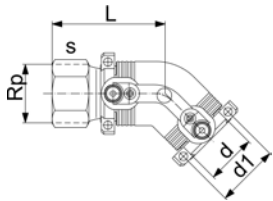

- PE 100 SDR 11 (ISO S5)
- 10 bar Gas / 16 bar Water
- With integral pipe fixation
- 4 mm pin connectors
- Limited path fusion indicators
- Supplied as kit

d [mm]	Rp [inch]	Code	GP	kg	d1 [mm]	L [mm]	s [mm]
32	1	720 150 258	6	0.354	44	80	40
40	1 ¼	720 150 259	6	0.530	54	88	50
50	1 ½	720 150 260	6	0.780	66	94	60
63	1	720 150 281	3	1.360	81	105	70
63	1 ¼	720 150 282	3	1.320	81	105	70
63	1 ½	720 150 283	3	1.240	81	105	70
63	2	720 150 261	3	1.090	81	105	70

PF 2 51 314 002

20 91 00

Transition Coupler PE/brass (Ms 58) with loose Nut

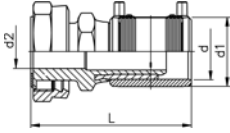

- PE 100 SDR 11 (ISO S5)
- Gas on request / 16 bar Water
- With integral pipe fixation
- 4 mm pin connectors
- Limited path fusion indicators
- Delivered as a kit. Further combinations modular system with threaded adapter and reductions
- Incl. flat gasket for water applications (KTW / WRC approved)

d [mm]	Rp [inch]	Code	GP	kg	d1 [mm]	d2 [mm]	L [mm]
25	¾	720 910 007	8	0.240	36	15	104
25	1	720 910 017	8	0.315	36	16	106
32	1	720 910 008	6	0.342	44	20	110
32	1 ¼	720 910 018	6	0.460	44	22	114
32	1 ½	720 910 028	6	0.480	44	22	114
40	1	720 910 009	6	0.465	54	21	119
40	1 ¼	720 910 019	6	0.520	54	25	123
40	1 ½	720 910 029	12	0.595	54	28	123
50	1	720 910 020	6	0.685	66	20	128
50	1 ¼	720 910 030	3	0.730	66	25	133
50	1 ½	720 910 010	3	0.774	66	29	133
50	2	720 910 040	3	0.980	66	36	137
63	1	720 910 021	3	1.025	81	20	137
63	1 ¼	720 910 031	3	1.060	81	25	141
63	1 ½	720 910 041	3	1.070	81	29	141
63	2	720 910 011	3	1.235	81	36	145
63	2 ½	720 910 051	3	1.495	81	46	148

PF 2 51 314 003

20 10 00

Transition Elbow 90° PE/brass (Ms 58) with loose Nut

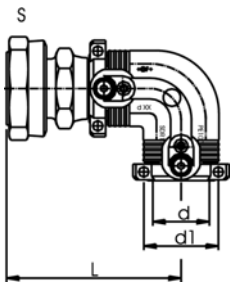

- PE 100 SDR 11 (ISO S5)
- Gas on request / 16 bar Water
- With integral pipe fixation
- 4 mm pin connectors
- Limited path fusion indicators
- Supplied as kit
- Incl. flat gasket for water applications (KTW / WRC approved)

d [mm]	Rp [inch]	Code	GP	kg	d1 [mm]	L [mm]
25	¾	720 100 007	8	0.260	36	90
25	1	720 100 017	8	0.335	36	92
32	1	720 100 008	6	0.370	44	91
32	1 ¼	720 100 018	6	0.490	44	95
32	1 ½	720 100 028	6	0.505	44	95
40	1	720 100 009	6	0.505	54	101
40	1 ¼	720 100 019	6	0.565	54	105
40	1 ½	720 100 029	6	0.635	54	105
50	1	720 100 020	6	0.760	66	111
50	1 ¼	720 100 030	3	0.805	66	116
50	1 ½	720 100 010	6	0.850	66	116
50	2	720 100 040	3	1.060	66	120
63	1	720 100 021	3	1.171	81	121
63	1 ¼	720 100 031	3	1.200	81	125
63	1 ½	720 100 041	6	1.210	81	125
63	2	720 100 011	3	1.375	81	129
63	2 ½	720 100 051	3	1.635	81	132

PF 2 51 314 003

20 15 00

Transition Elbow 45° PE/brass (Ms 58) with loose Nut

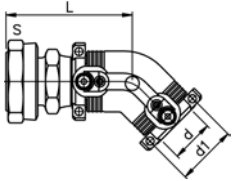

- PE 100 SDR 11 (ISO S5)
- Gas on request / 16 bar Water
- With integral pipe fixation
- 4 mm pin connectors
- Limited path fusion indicators
- Supplied as kit
- Incl. flat gasket for water applications (KTW / WRC approved)

d [mm]	Rp [inch]	Code	GP	kg	d1 [mm]	L [mm]	
32	1	720 150 008	6	0.355	44	82	
32	1 ¼	720 150 018	6	0.475	44	86	
32	1 ½	720 150 028	6	0.495	44	86	
40	1	720 150 009	6	0.485	54	89	
40	1 ¼	720 150 019	6	0.540	54	93	
40	1 ½	720 150 029	6	0.615	54	93	
50	1	720 150 020	6	0.725	66	96	
50	1 ¼	720 150 030	6	0.770	66	101	
50	1 ½	720 150 010	6	0.815	66	101	
50	2	720 150 040	3	1.024	66	105	
63	1	720 150 021	6	1.105	81	104	
63	1 ¼	720 150 031	6	1.140	81	108	
63	1 ½	720 150 041	6	1.150	81	108	
63	2	720 150 011	3	1.315	81	112	
63	2 ½	720 150 051	6	1.575	81	115	

PF 2 51 314 003

24 92 07

Transition Coupler PE/steel (stainless 1.4305) Male Thread

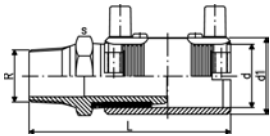

- PE 100 SDR 11 (ISO S5)
- 10 bar Gas / 16 bar Water
- With integral pipe fixation
- 4 mm pin connectors
- Limited path fusion indicators
- Delivered as a kit. Further combinations modular system with threaded adapter and reductions

d [mm]	R [inch]	Code	GP	kg	d1 [mm]	L [mm]	s [mm]
20	½	724 920 756	-	0.210	31	110	30
25	¾	724 920 757	6	0.260	36	111	35
32	1	724 920 758	6	0.347	44	117	40
32	1 ½	724 920 767	6	0.330	44	125	60
40	1 ¼	724 920 759	-	0.519	54	127	50
40	1 ½	724 920 772	6	0.690	66	143	60
50	1 ½	724 920 760	6	0.657	66	135	60
63	1 ½	724 920 771	3	0.904	81	147	70
63	2	724 920 761	3	0.963	81	147	70

PF 2 51 314 004

24 92 02

Transition Coupler PE/steel (stainless 1.4305) Female Thread

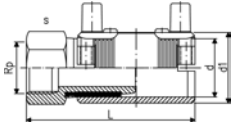

- PE 100 SDR 11 (ISO S5)
- 10 bar Gas / 16 bar Water
- With integral pipe fixation
- 4 mm pin connectors
- Limited path fusion indicators
- Supplied as kit

d [mm]	Rp [inch]	Code	GP	kg	d1 [mm]	L [mm]	s [mm]
20	½	724 920 256	-	0.197	31	100	30
25	¾	724 920 257	-	0.253	36	101	35
32	1	724 920 258	6	0.340	44	108	40
40	1 ¼	724 920 259	6	0.505	54	118	50
50	1 ½	724 920 260	-	0.725	66	126	60
63	2	724 920 261	-	0.995	81	138	70

PF 2 51 314 004

24 10 07

Transition Elbow 90° PE/steel (stainless 1.4305) Male Thread

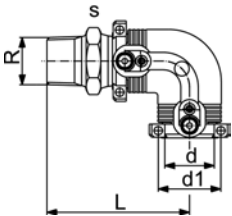

- PE 100 SDR 11 (ISO S5)
- 10 bar Gas / 16 bar Water
- With integral pipe fixation
- 4 mm pin connectors
- Limited path fusion indicators
- Supplied as kit

d [mm]	R [inch]	Code	GP	kg	d1 [mm]	L [mm]	s [mm]
20	½	724 100 756	6	0.211	31	96	30
25	¾	724 100 757	6	0.230	36	97	35
32	1	724 100 758	6	0.370	44	98	40
40	1 ¼	724 100 759	-	0.560	54	109	50
40	1 ½	724 100 772	6	0.730	54	109	60
50	1 ½	724 100 760	6	0.730	66	118	60
63	1 ½	724 100 771	3	1.040	81	132	70
63	2	724 100 761	3	1.105	81	132	70

PF 2 51 314 004

24 10 02

Transition Elbow 90° PE/steel (stainless 1.4305) Female Thread

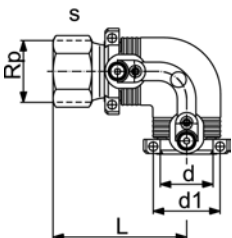

- PE 100 SDR 11 (ISO S5)
- 10 bar Gas / 16 bar Water
- With integral pipe fixation
- 4 mm pin connectors
- Limited path fusion indicators
- Supplied as kit

d [mm]	Rp [inch]	Code	GP	kg	d1 [mm]	L [mm]	s [mm]
20	½	724 100 256	6	0.211	31	86	30
25	¾	724 100 257	6	0.237	36	87	35
32	1	724 100 258	6	0.360	44	89	40
40	1 ¼	724 100 259	6	0.545	54	100	50
50	1 ½	724 100 260	-	0.805	66	109	60
63	2	724 100 261	3	1.135	81	123	70

PF 2 51 314 004



ELGEF® Plus
Electrofusion System

- ELGEF Plus Branch Fitting
- ELGEF Plus Modular System
- ELGEF Plus Saddles/Valves

ELGEF® Plus Branch Fitting

51 336 001

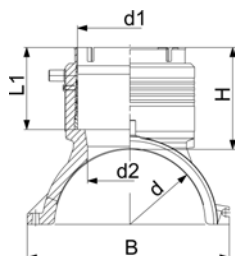

Branch Fitting

- PE 100 SDR 11 (ISO S5)
- 10 bar Gas / 16 bar Water
- Branch Fitting complete, incl. lower part and 3 screws
- Additional fixing with snatch hinge
- Electrofusion outlet with integrated pipe fixation
- Protected wire without medium contact
- 4 mm pin connectors
- Limited path fusion indicators
- * Delivered without lower part. Pipe fixation with multiple use assembly tool no. 193 281 027

d [mm]	d1 [mm]	Code	GP	kg	H [mm]	L [mm]	L1 [mm]	B [mm]	d2 [mm]
110	90	193 135 009	4	1.074	101	220	82	164	65
110	110	193 135 010	4	1.152	107	220	88	164	65
125	90	193 135 019	4	1.134	101	220	82	179	65
125	110	193 135 020	4	1.258	107	220	88	179	65
*140	90	193 135 029	4	1.134	101	220	81	195	65
*140	110	193 135 030	4	1.258	107	220	87	195	65
160	90	193 135 039	4	1.444	102	240	82	215	65
160	110	193 135 040	4	1.523	108	240	88	215	86
160	125	193 135 041	4	1.738	129	240	99	215	86
180	90	193 135 049	1	1.714	102	260	82	237	65
180	110	193 135 050	1	1.782	108	260	88	237	86
180	125	193 135 051	1	1.972	129	260	99	237	86
200	90	193 135 059	1	1.811	102	260	82	253	65
200	110	193 135 060	1	1.879	108	260	88	253	86
200	125	193 135 061	1	2.069	129	260	99	253	86
225	90	193 135 069	1	1.959	102	260	82	287	65
225	110	193 135 070	1	2.027	108	260	88	287	86
225	125	193 135 071	1	2.217	129	260	99	287	86
250	90	193 135 079	1	2.116	102	260	82	312	65
250	110	193 135 080	2	2.184	108	260	88	312	86
250	125	193 135 081	1	2.374	129	260	99	312	86

PF 2 51 336 001



PF 2 51 336 001

Multiple use Assembly Tool Branch fitting d140mm

- Only to be used with Branch Fitting d140mm
- Delivered as complete Kit including screws and belt

d [mm]	Code	kg
140	193 281 027	0.740



PF 2 51 336 001

Cross Connection Branch Fitting

-
-

d [mm]	d1 [mm]	Code	kg
110	160	193 280 880	0.250
180	250	193 280 881	0.250

51 336 001

Branch Fitting Topload

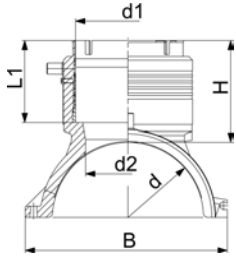

- PE 100 SDR 11 (ISO S5)
- 10 bar Gas / 16 bar Water
- Branch Fitting for assembling as Topload with tool 799.350.477
- Electrofusion outlet with integrated pipe fixation
- Protected wire without medium contact
- 4 mm pin connectors
- Limited path fusion indicators

d [mm]	d1 [mm]	Code	GP	kg	H [mm]	L [mm]	L1 [mm]	B [mm]	d2 [mm]
280 - 315	90	193 135 099	5	1.180	102	260	82	243	65
280 - 315	110	193 135 100	5	1.280	108	260	88	243	86
280 - 315	125	193 135 101	5	1.480	129	260	99	243	86
355 - 450	90	193 135 129	5	1.180	102	260	82	250	65
355 - 450	110	193 135 130	4	1.280	108	260	88	250	86
355 - 450	125	193 135 131	5	1.480	129	260	99	250	86
500 - 630	90	193 135 159	5	1.060	102	260	82	263	65
500 - 630	110	193 135 160	5	1.160	108	260	88	263	86
500 - 630	125	193 135 161	5	1.360	129	260	99	263	86

PF 2 51 336 001

ELGEF® Plus Modular System

Tapping Tee

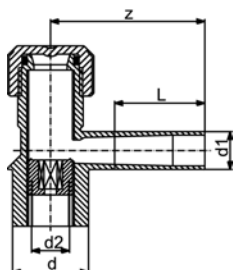

PF 2 51 313 001

- PE 100 SDR 11 (ISO S5)
- 10 bar Gas / 16 bar Water
- With integrated cutter to tap live mains under pressure
- For ELGEF® Plus Branch Saddle (53 131 000) d63-225, pipe SDR 11
- For ELGEF® Plus Branch Saddle (53 131 000) d75-315, pipe SDR 17
- *
- *For ELGEF® Plus Branch Saddle (53 131 000) d 250 - 315 mm, pipe SDR 11 and d 250 - 400 mm, pipe SDR 17
- Long fusion outlet
- O-ring sealed screw-cap

d [mm]	d1 [mm]	Code	GP	kg	d2 [mm]	L [mm]	z [mm]	SW [mm]	
63	20	193 280 358	15	0.384	32	69	130	17	
63	25	193 280 359	15	0.383	32	70	130	17	
63	32	193 280 184	12	0.383	32	76	130	17	
63	40	193 280 360	12	0.401	32	81	137	17	
63	63	193 280 185	12	1.120	32	100	160	17	
*63	63	193 280 711	12	1.120	35	100	160	17	

Tapping Tee with Gas-Stop Type U

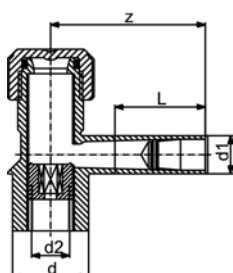

PF 2 51 313 001

- PE 100 SDR 11 (ISO S5)
- 5 bar Gas (for pressure 35 mbar -5 bar)
- With integrated cutter to tap live mains under pressure
- For ELGEF® Plus Branch Saddle (53 131 000) d63-225, pipe SDR 11
- For ELGEF® Plus Branch Saddle (53 131 000) d75-315, pipe SDR 17
- Gas-Stop System Pipelife Type U (GS 32/35 or GS 63/35)
- **Without overflow orifice**
- Set comes with Gas-Stop pre-assembled
- Installation instructions of Gas-Stop manufacturer are to be observed
- Long fusion outlet
- O-ring sealed screw-cap

d [mm]	d1 [mm]	Code	GP	kg	d2 [mm]	L [mm]	z [mm]	SW [mm]	Vn max [m³/h]	
63	32	193 281 054	20	0.430	32	76	130	17	35	
63	63	193 281 055	5	1.200	32	100	160	17	120	

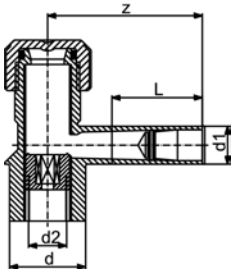

PF 2 51 313 001

Tapping Tee with Gas-Stop Type U UE

- PE 100 SDR 11 (ISO S5)
- 5 bar Gas (for pressure 35 mbar -5 bar)
- With integrated cutter to tap live mains under pressure
- For ELGEF® Plus Branch Saddle (53 131 000) d63-225, pipe SDR 11
- For ELGEF® Plus Branch Saddle (53 131 000) d75-315, pipe SDR 17
- Gas-Stop System Pipelife Type U (GS 32/35 UE or GS 63/35 UE)
- **With overflow orifice**
- Set comes with Gas-Stop pre-assembled
- Installation instructions of Gas-Stop manufacturer are to be observed
- Long fusion outlet
- O-ring sealed screw-cap

d [mm]	d1 [mm]	Code	GP	kg	d2 [mm]	L [mm]	z [mm]	SW [mm]	Vn max [m³/h]
63	32	193 281 052	20	0.430	32	76	130	17	35
63	63	193 281 053	5	1.200	32	100	160	17	120

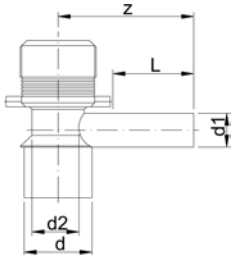

PF 2 51 313 001

Tapping Tee with Electrofusion Cap

- PE 100 SDR 11 (ISO S5)
- 10 bar Gas / 16 bar Water
- With integrated cutter to tap live mains under pressure
- For ELGEF® Plus Branch Saddle (53 131 000) d63-225, pipe SDR 11
- For ELGEF® Plus Branch Saddle (53 131 000) d75-315, pipe SDR 17
- Long fusion outlet

d [mm]	d1 [mm]	Code	GP	kg	D2 [mm]	d2 [mm]	L [mm]	z [mm]	SW [mm]
63	32	193 280 300	20	0.430	32	32	76	130	17
63	63	193 280 301	5	1.200	32	32	100	160	17

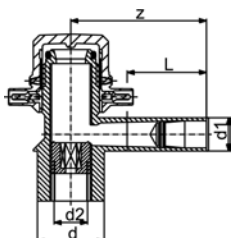

PF 2 51 313 001

Tapping Tee with Gas-Stop Type U and Electrofusion Cap

- PE 100 SDR 11 (ISO S5)
- 5 bar Gas (for pressure 35 mbar -5 bar)
- With integrated cutter to tap live mains under pressure
- For ELGEF® Plus Branch Saddle (53 131 000) d63-225, pipe SDR 11
- For ELGEF® Plus Branch Saddle (53 131 000) d75-315, pipe SDR 17
- Gas-Stop System Pipelife Type U (GS 32/35 or GS 63/35)
- **Without overflow orifice**
- Set comes with Gas-Stop pre-assembled
- Installation instructions of Gas-Stop manufacturer are to be observed
- Long fusion outlet

d [mm]	d1 [mm]	Code	kg	d2 [mm]	L [mm]	z [mm]	SW [mm]	Vn max [m³/h]
63	32	193 281 048	0.430	32	76	130	17	35
63	63	193 281 049	1.200	32	100	160	17	120



Tapping Tee with Gas-Stop Type U UE and Electrofusion Cap

- PE 100 SDR 11 (ISO S5)
- 5 bar Gas (for pressure 35 mbar -5 bar)
- With integrated cutter to tap live mains under pressure
- For ELGEF® Plus Branch Saddle (53 131 000) d63-225, pipe SDR 11
- For ELGEF® Plus Branch Saddle (53 131 000) d75-315, pipe SDR 17
- Gas-Stop System Pipelife Type U (GS 32/35 UE or GS 63/35 UE)
- **With overflow orifice**
- Set comes with Gas-Stop pre-assembled
- Installation instructions of Gas-Stop manufacturer are to be observed
- Long fusion outlet

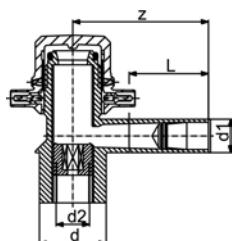

PF 2 51 313 001

d [mm]	d1 [mm]	Code	kg	d2 [mm]	L [mm]	z [mm]	SW [mm]	Vn max [m³/h]
63	32	193 281 046	0.430	32	76	130	17	35
63	63	193 281 047	1.200	32	100	160	17	120



Electrofusion Cap

- PE 100 SDR 11 (ISO S5)
- 10 bar Gas / 16 bar Water
- For ELGEF® Plus Tapping Saddles
- 193 280 153 suits for all Tapping Saddles Type Monobloc d63 mm and all Tapping Tee with outlet d20, d25, d32, d40 mm
- 193 280 154 suits for all Tapping Tee with outlet d63 mm

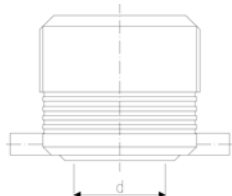

PF 2 51 313 001

d [mm]	Code	GP	kg
55	193 280 153	10	0.125
68	193 280 154	10	0.207

Tapping Valve Tee

- PE 100 SDR 11 (ISO S5)
- 10 bar Gas / 16 bar Water
- With integrated puncher(P) / cutter(C) to tap live mains under pressure
- For ELGEF® Plus Branch Saddle (53 131 000) d63-225, pipe SDR 11
- For ELGEF® Plus Branch Saddle (53 131 000) d 75 - 315 mm, pipe SDR 17 and d 250 - 400 mm, pipe SDR 26
- Opening of the spanner (SW) is 14
- Long fusion outlet

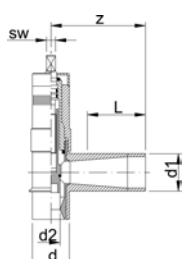

PF 2 51 313 002

d [mm]	d1 [mm]	Code	GP	kg	d2 [mm]	L [mm]	z [mm]	Description
63	32	193 281 558	5	1.430	21	70	127	System P
63	63	193 280 680	5	2.600	30	100	160	System P
63	32	193 281 250	5	1.405	27	70	127	System C
63	63	193 280 410	5	2.405	33	100	160	System C



Tapping Valve Tee with Gas-Stop Type U

- PE 100 SDR 11 (ISO S5)
- 5 bar Gas (for pressure 35 mbar -5 bar)
- With integrated puncher(P) / cutter(C) to tap live mains under pressure
- For ELGEF® Plus Branch Saddle (53 131 000) d63-225, pipe SDR 11
- For ELGEF® Plus Branch Saddle (53 131 000) d 75 - 315 mm, pipe SDR 17 and d 250 - 400 mm, pipe SDR 26
- Gas-Stop System Pipelife Type U (GS 32/35 or GS 63/35)
- **Without overflow orifice**
- Set comes with Gas-Stop pre-assembled
- Installation instructions of Gas-Stop manufacturer are to be observed
- Opening of the spanner (SW) is 14
- Long fusion outlet

d [mm]	d1 [mm]	Code	GP	kg	d2 [mm]	L1 [mm]	z [mm]	Vn max [m³/h]	Description
63	32	193 281 131	5	2.700	21	70	127	35	System P
63	63	193 281 060	5	2.700	30	100	160	120	System P
63	32	193 281 178	5	1.400	27	70	127	35	System C
63	63	193 281 061	5	1.400	33	100	160	120	System C

PF 2 51 313 002



Tapping Valve Tee with Gas-Stop Type U UE

- PE 100 SDR 11 (ISO S5)
- 5 bar Gas (for pressure 35 mbar -5 bar)
- With integrated puncher(P) / cutter(C) to tap live mains under pressure
- For ELGEF® Plus Branch Saddle (53 131 000) d63-225, pipe SDR 11
- For ELGEF® Plus Branch Saddle (53 131 000) d 75 - 315 mm, pipe SDR 17 and d 250 - 400 mm, pipe SDR 26
- Gas-Stop System Pipelife Type U (GS 32/35 UE or GS 63/35 UE)
- **With overflow orifice**
- Set comes with Gas-Stop pre-assembled
- Installation instructions of Gas-Stop manufacturer are to be observed
- Opening of the spanner (SW) is 14
- Long fusion outlet

d [mm]	d1 [mm]	Code	GP	kg	d2 [mm]	L1 [mm]	z [mm]	Vn max [m³/h]	Description
63	32	193 281 130	5	2.700	21	70	127	35	System P
63	63	193 281 058	5	2.700	30	100	160	120	System P
63	32	193 281 177	-	2.700	27	70	127	35	System C
63	63	193 281 059	5	2.700	33	100	160	120	System C

PF 2 51 313 002

Stop-Off Adaptor with brass plug

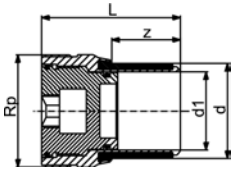

PF 2 51 313 001

- PE 100 SDR 11 (ISO S5)
- 10 bar Gas / 16 bar Water
- For ELGEF® Plus Branch Saddle (53 131 000) d 63 - 400 mm, pipe SDR 11
- For main dimension d 63 and d 75mm we recommend a maximum cutting diameter of d = 39mm

d [mm]	Rp [inch]	Code	GP	kg	d1 [mm]	L [mm]	z [mm]	SW [mm]
63	2 ½	193 280 274	6	1.489	50	93	46	19
63	2 ½	193 280 294	6	1.462	56	93	46	19

Stop-Off Adaptor PE

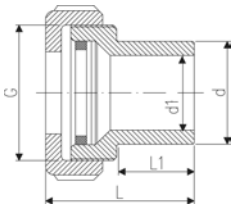

PF 2 51 313 001

- PE 100 SDR 11 (ISO S5)
- 10 bar Gas / 16 bar Water
- For ELGEF® Plus Branch Saddle (53 131 000) d 63 - 400 mm, pipe SDR 11, d 75 - 400 mm, pipe SDR 17
- PE Stop-Off insert d 63
- Plug with rubber seal
- PVP nut
- For main dimension d 63 and d 75mm we recommend a maximum cutting diameter of d = 39mm

d [mm]	G [inch]	Code	GP	kg	d1 [mm]	L [mm]	z [mm]
63	2 ¾	193 280 279	10	0.300	51	87	45

Spigot with Cutter

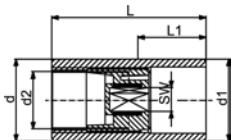

PF 2 51 313 001

- PE 100 SDR 11 (ISO S5)
- 10 bar Gas / 16 bar Water
- For ELGEF® Plus Branch Saddle (53 131 000) d63-225, pipe SDR 11
- For ELGEF® Plus Branch Saddle (53 131 000) d 75 - 315 mm, pipe SDR 17 and d 250 - 400 mm, pipe SDR 26

d [mm]	d1 [mm]	Code	GP	kg	d2 [mm]	L [mm]	L1 [mm]	SW [mm]
63	32	193 280 272	20	0.200	19	113	50	13
63	63	193 280 273	12	0.701	32	120	50	17

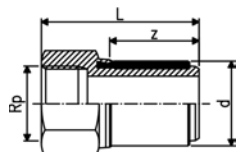

PF 2 51 314 002

Transition adaptor PE/brass (Ms 58) Female thread

- PE 100 SDR 11 (ISO S5)
- 10 bar Gas / 16 bar Water
- For ELGEF® Plus Couplers and Fittings

d [mm]	Rp [inch]	Code	kg	L [mm]	z [mm]
32	1	720 920 208	0.250	71	35
40	1 ¼	720 920 209	0.397	77	39
50	1 ½	720 920 210	0.589	81	43
63	1	720 920 221	1.071	89	47
63	1 ¼	720 920 231	1.027	89	47
63	1 ½	720 920 241	0.950	89	47
63	2	720 920 211	0.800	89	47

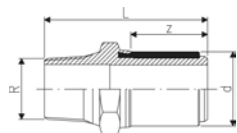

PF 2 51 314 002

Transition Adaptor PE/brass (Ms 58) Male thread

- PE 100 SDR 11 (ISO S5)
- 10 bar Gas / 16 bar Water
- For ELGEF® Plus Couplers and Fittings

d [mm]	R [inch]	Code	kg	L [mm]	z [mm]
20	½	720 920 706	0.151	75	33
25	¾	720 920 707	0.195	76	33
32	1	720 920 708	0.273	80	35
32	1 ¼	720 920 718	0.389	82	35
32	1 ½	720 920 728	0.454	82	35
40	1	720 920 719	0.370	84	39
40	1 ¼	720 920 709	0.425	86	39
40	1 ½	720 920 729	0.490	86	39
50	1	720 920 720	0.479	88	43
50	1 ¼	720 920 730	0.546	90	43
50	1 ½	720 920 710	0.528	90	43
63	1 ¼	720 920 721	0.702	94	47
63	1 ½	720 920 731	0.698	94	47
63	2	720 920 711	0.792	98	47

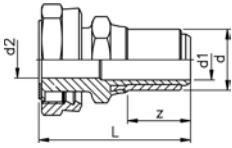

Transition adaptor PE/brass Loose nut (Ms 58)

- PE 100 SDR 11 (ISO S5)
- Gas on request / 16 bar Water
- For ELGEF® Plus Couplers and Fittings
- Incl. flat gasket for water applications (KTW / WRC approved)

d [mm]	Rp [inch]	Code	kg	d2 [mm]	L [mm]	z [mm]
25	¾	720 920 007	0.165	15	68	32
25	1	720 920 017	0.240	16	70	32
32	1	720 920 008	0.255	20	72	34
32	1 ¼	720 920 018	0.374	22	76	34
32	1 ½	720 920 028	0.393	22	76	34
40	1	720 920 009	0.349	21	77	38
40	1 ¼	720 920 019	0.406	25	81	38
40	1 ½	720 920 029	0.480	28	81	38
50	1	720 920 020	0.532	20	82	42
50	1 ¼	720 920 030	0.577	25	87	42
50	1 ½	720 920 010	0.621	29	87	42
50	2	720 920 040	0.831	36	91	42
63	1	720 920 021	0.816	20	87	46
63	1 ¼	720 920 031	0.850	25	91	46
63	1 ½	720 920 041	0.862	29	91	46
63	2	720 920 011	1.025	36	95	46
63	2 ½	720 920 051	1.284	46	98	46

PF 2 51 314 003

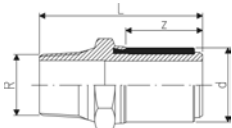

Transition Adaptor PE/steel (stainless 1.4305) Male thread

- PE 100 SDR 11 (ISO S5)
- 10 bar Gas / 16 bar Water
- For ELGEF® Plus Couplers and Fittings

d [mm]	R [inch]	Code	kg	L [mm]	z [mm]
20	½	724 920 706	0.139	75	33
25	¾	724 920 707	0.189	76	33
32	1	724 920 708	0.256	80	35
32	1 ½	724 920 718	0.400	80	35
40	1 ¼	724 920 709	0.404	86	39
40	1 ½	724 920 719	0.572	86	39
50	1 ½	724 920 710	0.502	90	43
63	1 ½	724 920 721	0.690	98	47
63	2	724 920 711	0.756	98	47

PF 2 51 314 004

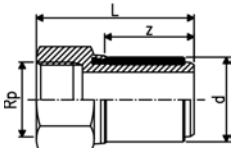

Transition adaptor PE/steel (stainless 1.4305) Female thread

- PE 100 SDR 11 (ISO S5)
- 10 bar Gas / 16 bar Water
- For ELGEF® Plus Couplers and Fittings

d [mm]	Rp [inch]	Code	kg	L [mm]	z [mm]
20	½	724 920 206	0.153	65	33
25	¾	724 920 207	0.195	66	33
32	1	724 920 208	0.250	71	35
40	1 ¼	724 920 209	0.388	77	39
50	1 ½	724 920 210	0.575	81	43
63	2	724 920 211	0.785	89	47

PF 2 51 314 004



Union Adaptor

- With female thread and PE-union end
- The Code Nr. includes the entire union (galvanised)
- **PE 100 SDR 11 (ISO S5)**

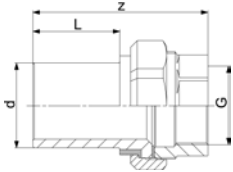

PF 2 90 703 001

d	Rp	Code	GP	kg	L	L2	SW1	G	
[mm]	[inch]				[mm]	[mm]	[mm]	[inch]	
20	½	701 485 560	30	0.152	94	52	27	1	
25	¾	701 485 561	25	0.252	100	52	32	11/4	
32	1	701 485 562	20	0.331	108	54	34	11/2	
40	1 ¼	701 485 563	12	0.590	114	57	43	2	
50	1 ½	701 485 564	15	0.645	124	65	50	21/4	
63	2	701 485 565	16	0.975	134	65	61	23/4	

Transition Fittings PE / steel

- **PE 100 SDR 11 (ISO S5)**
- 6 bar Gas / 16 bar Water
- Electrofusion weldable
- Steel pipe acc. to EN 10208-1, PE coated for corrosion resistance

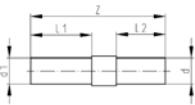

* Steel pipe without plastic shroud

d	d1	Code	kg	d1	z	L1	L2	
[mm]	[inch]			[mm]	[mm]	[mm]	[mm]	
*20	½	775 641 502	0.500	21	450	310	85	
25	¾	775 641 507	0.640	27	460	310	100	
32	1	775 641 510	0.940	34	460	310	100	
40	1 ¼	775 641 514	1.200	42	460	310	100	
50	1 ½	775 641 518	1.440	48	460	310	100	
63	2	775 641 524	1.930	60	460	310	100	
75	2 ½	775 641 632	2.800	76	510	310	100	
90	3	775 641 636	3.700	89	520	310	100	
110	3	775 641 640	3.800	89	520	310	100	
110	4	775 641 641	6.600	114	520	310	100	
125	4	775 641 645	6.700	114	520	310	100	
160	6	775 641 655	11.300	168	580	310	120	
180	6	775 641 659	11.800	168	580	310	130	
200	8	775 642 664	19.100	219	600	310	130	
225	8	775 642 669	19.500	219	600	310	130	
250	8	775 642 665	20.500	219	620	310	160	
250	10	775 642 666	30.000	273	620	310	160	
280	10	775 642 673	31.000	273	620	310	160	
315	12	775 642 672	47.000	324	630	310	220	
355	12	775 642 675	49.000	324	630	310	220	
400	16	775 642 678	94.000	406	640	310	220	

PF 1 27 142 415



PE Adaptor Female thread

- PE 80 SDR 11 (ISO S5)
- 5 bar Gas / 12,5 bar Water
- Connection to plastic or metal
- Reinforcing ring stainless (A2)
- For ELGEF® Plus Branch Saddle (53 131 000) d 63 - 400 mm, pipe SDR 11, d 75 - 400 mm, pipe SDR 17
- Parallel female thread

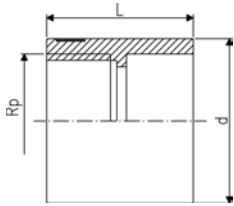

PF 2 51 313 001

d [mm]	Rp [inch]	Code	GP	kg	L [mm]	
63	1 ½	173 281 925	30	0.096	54	

Instrument Installation Spigots, PE80, Thread G

Model:

- For the connection of measuring instruments only
- Usable with all types of electrofusion couplers

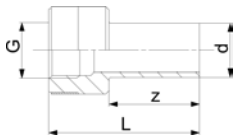

PF 2 90 703 001

d [mm]	G [inch]	Code	GP	kg	L [mm]	z [mm]	
20	½	701 473 809	-	0.050	90	52	
25	½	701 473 803	-	0.050	90	52	
25	¾	701 473 810	-	0.060	90	52	
32	½	701 473 804	-	0.060	90	52	
32	1	701 473 811	-	0.060	90	54	
40	½	701 473 812	-	0.049	75	57	
40	1 ¼	701 473 806	-	0.090	100	57	
50	½	701 473 813	-	0.075	80	63	
50	1 ¼	701 473 805	-	0.060	80	63	
50	1 ½	701 473 807	-	0.100	105	63	
63	½	701 473 814	-	0.117	80	65	
63	2	701 473 808	-	0.110	110	65	

Excess Flow Valves

53 92 06

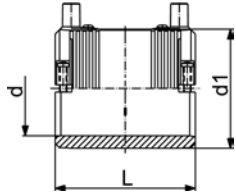

PF 2 51 314 009

Coupler with integrated Excess Flow Valve Type D with overflow orifice

- PE 100 SDR 11 (ISO S5)
- 1 bar Gas
- Pressure rating **25 mbar - 1 bar**. Excess Flow Valve system Mertik Maxitrol
- With integral pipe fixation
- 4 mm pin connectors
- Limited path fusion indicators

d [mm]	Code	GP	kg	d1 [mm]	L [mm]	z [mm]	
32	753 920 608	50	0.101	44	72	2	
40	753 920 609	50	0.160	54	80	2	
50	753 920 610	10	0.279	66	88	2	
63	753 920 611	10	0.382	81	96	2	

53 92 07

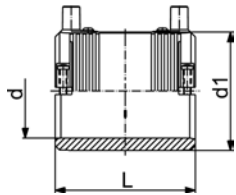

PF 2 51 314 009

Coupler with integrated Excess Flow Valve Type B with overflow orifice

- PE 100 SDR 11 (ISO S5)
- 5 bar Gas
- Pressure rating **100 mbar - 5 bar**. Excess Flow Valve system Mertik Maxitrol
- With integral pipe fixation
- 4 mm pin connectors
- Limited path fusion indicators

d [mm]	Code	GP	kg	d1 [mm]	L [mm]	z [mm]	
32	753 920 708	50	0.103	44	72	2	
40	753 920 709	50	0.163	54	80	2	
50	753 920 710	10	0.286	66	88	2	
63	753 920 711	10	0.394	81	96	2	

53 90 16

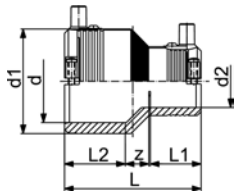

PF 2 51 314 009

Reducer with integrated Excess Flow Valve Type D with overflow orifice

- PE 100 SDR 11 (ISO S5)
- 1 bar Gas
- Pressure rating **25 mbar - 1 bar**. Excess Flow Valve system Mertik Maxitrol
- With integral pipe fixation
- 4 mm pin connectors
- Limited path fusion indicators

d [mm]	d2 [mm]	Code	GP	kg	d1 [mm]	L [mm]	L1 [mm]	L2 [mm]	z [mm]	
63	32	753 901 605	10	0.213	81	106	35	48	23	
63	40	753 901 606	10	0.249	81	106	39	48	19	
63	50	753 901 607	10	0.381	81	106	43	48	15	

53 90 16

Reducer with integrated Excess Flow Valve Type B with overflow orifice

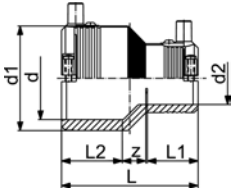







PF 2 51 314 009

- PE 100 SDR 11 (ISO S5)
- 5 bar Gas
- Pressure rating **100 mbar - 5 bar**. Excess Flow Valve system Mertik Maxitrol
- With integral pipe fixation
- 4 mm pin connectors
- Limited path fusion indicators

d [mm]	d2 [mm]	Code	GP	kg	d1 [mm]	L [mm]	L1 [mm]	L2 [mm]	z [mm]	
63	32	753 901 612	10	0.215	81	106	35	48	23	
63	40	753 901 613	10	0.252	81	106	39	48	19	
63	50	753 901 614	10	0.393	81	106	43	48	15	

ELGEF Plus Assembly Instructions for Saddles and Tapping Valves

Sequence of work	Tapping saddle Monoblock d 40-d 63	Tapping saddle with rotatable outlet d 63-d 315	Pressure tapping valve d 63-d 315	Spigot saddle d 63-d 315	Stopoff saddle d 63-d 315	Repair saddle d 63-d 315	Strengthening saddle (24 V) d 40-d 250
							
1 Clean pipe in fusion area, remove oxide film of pipe using scraper (machine it)							
2 Clean pipe in fusion area using duster and PE cleaner							
3 Remove saddle from packaging without touching; hang lower part on its hinge							
4 Place saddle on pipe and tighten with pre-mounted screws (stress clamp for strengthening saddle)		<= 250	<= 250	<= 250	<= 250	<= 250	
5 Remove modular system component from the packaging and assemble (without touching fusion surface)							
6 Place saddle on pipe and assemble with top-Load tool (detailed assembly instructions)		>= 250	>= 250	>= 250	>= 250	>= 250	
7 Align rotatable outlet and firmly fasten integrated bracket of saddle outlet							
8 Fusion in accordance with operating instructions of unit							
9 After fusion: Check fusion indicator; check fusion unit display, then remove cable							
10 Wait for minimum time until pressure test, then conduct pressure test *1							
11 Remove screw and fusion cap							
12 Tap clockwise, withdraw cutter up to top stop; (detailed assembly instructions) *1							
13 Fasten screw and fusion cap by hand							
14 Fusion in accordance with operating instructions of unit							

 = compulsory  = if required

*1 Minimum cooling time for saddles in minutes

d (mm)	Pressure test/Tapping	
	p <= 6 bar (min)	p <= 24 bar (min)
40	10	30
63-315	20	60

p = test pressure

ELGEF® Plus Saddles and Valves

53 131 000

Electrofusion Saddle



- PE 100 SDR 11 (ISO S5)
- 10 bar Gas / 16 bar Water
- Complete with lower part
- 4 mm pin connectors
- Limited path fusion indicators

* = not suitable for all tapping-tee, tapping-valve and spigot with cutter of the modular systems

** = not suitable for all tapping-tee, tapping-valve and spigot with cutter of the modular systems / delivery without lower part for assembling as Top load with tool 799.350.475

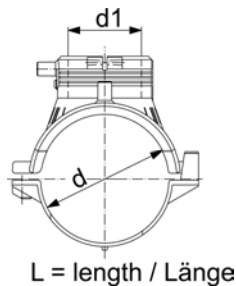

d [mm]	d1 [mm]	Code	GP	kg	L [mm]
63	63	193 131 037	5	0.335	165
75	63	193 131 047	5	0.465	165
90	63	193 131 057	5	0.425	165
110	63	193 131 067	3	0.493	165
125	63	193 131 077	3	0.523	165
140	63	193 131 087	3	0.523	165
160	63	193 131 097	4	0.526	165
180	63	193 131 107	5	0.632	165
200	63	193 131 117	5	0.651	165
225	63	193 131 127	4	0.653	165
*250	63	193 131 137	3	0.665	165
**280	63	193 131 147	8	0.370	165
**315 - 400	63	193 131 157	8	0.370	165

PF 2 51 313 001

53 130 000

Repair Saddle



- PE 100 SDR 11 (ISO S5)
- 10 bar Gas / 16 bar Water
- Complete with lower part
- 4 mm pin connectors
- Limited path fusion indicators
- Supplied as kit including Spigot Cap (753.961.011)
- *Delivery without lower part for assembling as Top Load with tool no. 799.350.475

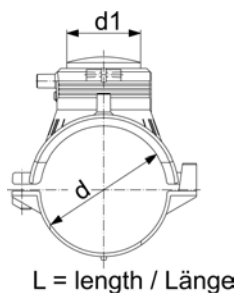

d [mm]	d1 [mm]	Code	GP	kg	L [mm]
63	63	193 130 037	5	0.433	165
75	63	193 130 047	3	0.574	165
90	63	193 130 057	5	0.538	165
110	63	193 130 067	3	0.592	165
125	63	193 130 077	3	0.622	165
140	63	193 130 087	3	0.660	165
160	63	193 130 097	3	0.627	165
180	63	193 130 107	5	0.733	165
200	63	193 130 117	5	0.751	165
225	63	193 130 127	5	0.768	165
250	63	193 130 137	3	0.758	165
*280	63	193 130 147	6	0.450	165
*315 - 400	63	193 130 157	6	0.450	165

PF 2 51 313 001

53 149 000

Stop-Off Saddle (Kit) maximum passage 56 mm

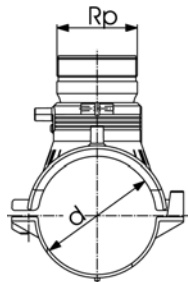

L = length / Länge

- PE 100 SDR 11 (ISO S5)
- 10 bar Gas / 16 bar Water
- Complete with lower part
- Stop-Off insert (brass 58) and plug
- 4 mm pin connectors
- Limited path fusion indicators
- Stop-Off insert with outside thread Rp 2 1/2" and internal thread Rp 2" suited for common tapping devices permitting "gas-tight" installation
- *Delivery without lower part for assembling as Top Load with tool no. 799.350.475
- For main dimension d 63 and d 75mm we recommend a maximum cutting diameter of d = 39mm

d [mm]	Rp [inch]	Code	GP	kg	L [mm]
63	2 ½	193 149 437	3	1.744	165
75	2 ½	193 149 447	3	1.900	165
90	2 ½	193 149 457	3	1.865	165
110	2 ½	193 149 467	3	1.916	165
125	2 ½	193 149 477	3	1.945	165
140	2 ½	193 149 487	3	1.945	165
160	2 ½	193 149 497	5	1.954	165
180	2 ½	193 149 507	5	2.055	165
200	2 ½	193 149 517	5	2.074	165
225	2 ½	193 149 527	5	2.062	165
250	2 ½	193 149 537	5	2.080	165
*280	2 ½	193 149 547	5	1.550	165
*315 - 400	2 ½	193 149 557	5	1.550	165

PF 2 51 313 001

53 149 200

Stop-off Saddle with PE-Adaptor maximum passage 50 mm

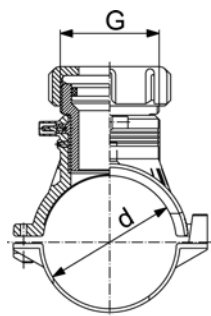

L = length / Länge

- PE 100 SDR 11 (ISO S5)
- 10 bar Gas / 16 bar Water
- Complete with lower part
- Supplied as Kit with PE-Stop-Off Adaptor
- PE Stop-Off insert (for use with by-pass unit 799150376)
- 4 mm pin connectors
- Limited path fusion indicators
- *Delivery without lower part for assembling as Top Load with tool no. 799.350.475

d [mm]	G [inch]	Code	GP	kg	L [mm]
63	2 ¾	193 149 237	5	0.630	165
75	2 ¾	193 149 247	5	0.765	165
90	2 ¾	193 149 257	5	0.734	165
110	2 ¾	193 149 267	5	0.782	165
125	2 ¾	193 149 277	5	0.820	165
140	2 ¾	193 149 287	3	0.820	165
160	2 ¾	193 149 297	5	0.816	165
180	2 ¾	193 149 307	5	0.920	165
200	2 ¾	193 149 317	5	0.944	165
225	2 ¾	193 149 327	5	0.943	165
250	2 ¾	193 149 337	5	0.950	165
*280	2 ¾	193 149 347	6	0.920	165
*315 - 400	2 ¾	193 149 357	5	0.920	165

PF 2 51 313 001

53 131 400

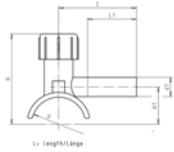

PF 2 51 313 001

Tapping Saddle Monobloc topload

- PE 100 SDR 11 (ISO S5)
- 10 bar Gas / 16 bar Water
- With integrated cutter to tap live mains under pressure
- Delivery without lower part for assembling as Topload with tool no. 799 301 558
- 4 mm pin connectors
- Fusion indicator
- Long fusion outlet
- O-ring sealed screw-cap

d [mm]	d1 [mm]	Code	GP	kg	d2 [mm]	H [mm]	H1 [mm]	L [mm]	L1 [mm]	z [mm]
32	20	193 281 459	10	0.142	12	83	29	101	65	90

53 131 400

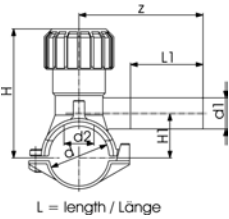

PF 2 51 313 001

Tapping Saddle Monobloc version

- PE 100 SDR 11 (ISO S5)
- 10 bar Gas / 16 bar Water
- With integrated cutter to tap live mains under pressure
- Complete with lower part
- 4 mm pin connectors
- Limited path fusion indicators
- Long fusion outlet
- O-ring sealed screw-cap

d [mm]	d1 [mm]	Code	GP	kg	d2 [mm]	H [mm]	H1 [mm]	L [mm]	L1 [mm]	z [mm]
40	20	193 131 412	6	0.270	16	99	33	103	70	102
40	25	193 131 413	6	0.272	16	99	33	103	70	102
40	32	193 131 414	6	0.277	16	99	33	103	70	120
50	20	193 131 422	5	0.260	16	104	38	103	70	102
50	25	193 131 423	5	0.262	16	104	38	103	70	102
50	32	193 131 424	5	0.270	16	104	38	103	70	120



Tapping Saddle Monobloc version



- PE 100 SDR 11 (ISO S5)
- 10 bar Gas / 16 bar Water
- With integrated cutter to tap live mains under pressure
- Complete with moulded-on lower part
- 4 mm pin connectors
- Limited path fusion indicators
- Long fusion outlet
- O-ring sealed screw-cap

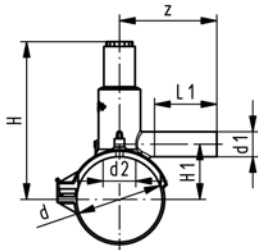

L = length / Länge

d [mm]	d1 [mm]	Code	GP	kg	d2 [mm]	H [mm]	H1 [mm]	L [mm]	L1 [mm]	z [mm]
63	20	193 131 932	20	0.390	25	146	44	144	76	110
63	25	193 131 933	20	0.390	25	146	44	144	76	110
63	32	193 131 934	20	0.390	25	146	44	144	76	110
90	20	193 131 952	12	0.450	32	198	61	162	76	115
90	25	193 131 953	12	0.450	32	198	61	162	76	115
90	32	193 131 954	12	0.450	32	198	61	162	76	115
110	20	193 131 962	9	0.535	32	208	71	162	76	115
110	25	193 131 963	9	0.665	32	208	71	162	76	115
110	32	193 131 964	9	0.535	32	208	71	162	76	125
110	63	193 131 967	8	0.600	32	208	71	162	100	160
125	20	193 131 972	6	0.600	32	216	79	162	76	120
125	25	193 131 973	6	0.600	32	216	79	162	76	120
125	32	193 131 974	6	0.600	32	216	79	162	76	120
160	20	193 131 992	6	0.665	32	233	96	162	76	120
160	25	193 131 993	6	0.665	32	233	96	162	76	125
160	32	193 131 994	6	0.665	32	233	96	162	76	130
160	63	193 131 997	6	0.700	32	233	96	162	100	170

PF 2 51 313 001

53 132 400

Tapping Saddle (Kit) Monobloc version



- PE 100 SDR 11 (ISO S5)
- 10 bar Gas / 16 bar Water
- With integrated cutter to tap live mains under pressure
- Complete with lower part
- 4 mm pin connectors
- Limited path fusion indicators
- Long fusion outlet
- O-ring sealed screw-cap
- Supplied as Kit with enclosed service line fitting (ELGEF® Plus Coupler or Reducer)

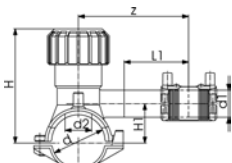

L = length / Länge

d [mm]	d1 [mm]	Code	GP	kg	d2 [mm]	H [mm]	H1 [mm]	L [mm]	L1 [mm]	z [mm]
40	20	193 132 412	6	0.324	16	99	33	103	70	102
40	25	193 132 413	6	0.331	16	99	33	103	70	102
40	32	193 132 414	5	0.353	16	99	33	103	70	120
50	20	193 132 422	5	0.325	16	105	38	103	70	102
50	25	193 132 423	5	0.323	16	105	38	103	70	102
50	32	193 132 424	5	0.342	16	105	38	103	70	120
63	40	193 132 435	6	0.534	25	134	44	126	70	130

PF 2 51 313 001

53 131 600

Tapping Saddle with Electrofusion Cap Monobloc version

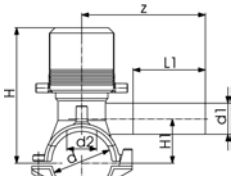

L = length / Länge

PF 2 51 313 001

- PE 100 SDR 11 (ISO S5)
- 10 bar Gas / 16 bar Water
- With integrated cutter to tap live mains under pressure
- Complete with lower part
- 4 mm pin connectors
- Limited path fusion indicators
- Long fusion outlet
- Electrofusion Cap

d [mm]	d1 [mm]	Code	GP	kg	d2 [mm]	H [mm]	H1 [mm]	L [mm]	L1 [mm]	z [mm]	
63	20	193 131 632	6	0.479	25	134	44	126	71	130	
63	25	193 131 633	6	0.483	25	134	44	126	71	130	
63	32	193 131 634	4	0.483	25	134	44	126	76	130	

53 130 600

Tapping Saddle with Gas-Stop Type 1-5 bar Monobloc version

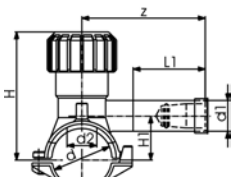

L = length / Länge

PF 2 51 313 003

- PE 100 SDR 11 (ISO S5)
- 5 bar Gas (for pressure 1 bar -5 bar)
- With integrated cutter to tap live mains under pressure
- Gas-Stop System Pipelife (GS 20/1 or GS 32/1)
- **Without overflow orifice**
- Set comes with Gas-Stop pre-assembled
- Installation instructions of Gas-Stop manufacturer are to be observed
- Complete with lower part
- 4 mm pin connectors
- Limited path fusion indicators
- Long fusion outlet
- O-ring sealed screw-cap

d [mm]	d1 [mm]	Code	GP	kg	d2 [mm]	H [mm]	H1 [mm]	L [mm]	L1 [mm]	z [mm]	Vn max [m³/h]
40	20	193 281 113	6	0.270	16	99	33	103	70	102	25
40	32	193 281 152	6	0.277	16	99	33	103	70	120	100

53 130 600

Tapping Saddle with Gas-Stop Type 1-5 bar Monobloc version

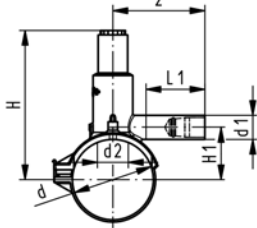

L = length / Länge

- PE 100 SDR 11 (ISO S5)
- 5 bar Gas (for pressure 1 bar -5 bar)
- With integrated cutter to tap live mains under pressure
- Complete with moulded-on lower part
- Gas-Stop System Pipelife (GS 20/1 or GS 32/1)
- **Without overflow orifice**
- Set comes with Gas-Stop pre-assembled
- Installation instructions of Gas-Stop manufacturer are to be observed
- 4 mm pin connectors
- Limited path fusion indicators
- Long fusion outlet
- O-ring sealed screw-cap

d [mm]	d1 [mm]	Code	GP	kg	d2 [mm]	H [mm]	H1 [mm]	L [mm]	L1 [mm]	z [mm]	Vn max [m ³ /h]
63	20	193 130 432	20	0.400	25	146	44	144	76	110	25
63	32	193 130 434	20	0.400	25	146	44	144	76	110	100
90	20	193 130 452	12	0.564	32	198	61	162	76	115	25
90	32	193 130 454	12	0.624	32	198	61	162	76	115	100
110	20	193 130 462	9	0.615	32	208	71	162	76	115	25
110	32	193 130 464	9	0.677	32	208	71	162	76	125	100
125	20	193 130 472	6	0.664	32	216	79	162	76	120	25
125	32	193 130 474	6	0.724	32	216	79	162	76	120	100
160	20	193 130 492	6	0.725	32	233	96	162	76	120	25
160	32	193 130 494	6	0.786	32	233	96	162	76	130	100

PF 2 51 313 003

53 130 600

Tapping Saddle with Gas-Stop Type AD UE Monobloc version

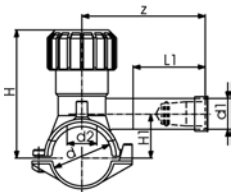

L = length / Länge

- PE 100 SDR 11 (ISO S5)
- 1 bar Gas (for pressure **25 mbar - 1 bar**)
- With integrated cutter to tap live mains under pressure
- Gas-Stop System Pipelife Type AD (GS 32/25 UE)
- **With overflow orifice**
- Set comes with Gas-Stop pre-assembled
- Installation instructions of Gas-Stop manufacturer are to be observed
- Complete with lower part
- 4 mm pin connectors
- Limited path fusion indicators
- Long fusion outlet
- O-ring sealed screw-cap

d [mm]	d1 [mm]	Code	GP	kg	d2 [mm]	H [mm]	H1 [mm]	L [mm]	L1 [mm]	z [mm]	Vn max [m ³ /h]
40	32	193 130 614	6	0.290	16	99	33	103	76	120	10
50	32	193 130 624	6	0.283	16	104	38	103	76	120	10
63	32	193 130 634	6	0.446	25	134	44	126	76	130	10

PF 2 51 313 003

53 130 800

Tapping Saddle with Gas-Stop Type B UE Monobloc Version

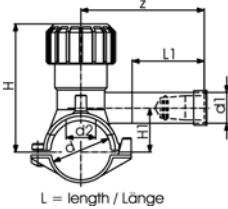

L = length / Länge

- PE 100 SDR 11 (ISO S5)
- 5 bar Gas (for pressure **150 mbar - 5 bar**)
- With integrated cutter to tap live mains under pressure
- Gas-Stop System Pipelife Type B (GS 32/150 UE)
- **With overflow orifice**
- Set comes with Gas-Stop pre-assembled
- Installation instructions of Gas-Stop manufacturer are to be observed
- Complete with lower part
- 4 mm pin connectors
- Limited path fusion indicators
- Long fusion outlet
- O-ring sealed screw-cap

d	d1	Code	GP	kg	D2	d2	H	H1	L	L1	z	Vn max	
[mm]	[mm]				[mm]	[mm]	[mm]	[mm]	[mm]	[mm]	[mm]	[m ³ /h]	
40	32	193 130 814	6	0.290	16	16	99	33	103	76	120	45	
50	32	193 130 824	6	0.283	16	16	104	38	103	76	120	45	
63	32	193 130 834	6	0.446	25	25	134	44	126	76	130	45	

PF 2 51 313 003

Tapping Saddle with 360° rotatable outlet

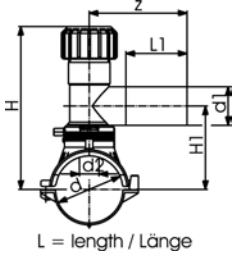

- PE 100 SDR 11 (ISO S5)
- 10 bar Gas / 16 bar Water
- With integrated cutter to tap live mains under pressure
- Complete with lower part
- 4 mm pin connectors
- Limited path fusion indicators
- Long fusion outlet
- O-ring sealed screw-cap
- D 315 - 400 mm: application is limited on pipes d 355 and d 400 mm. Not suitable for pipes with an SDR value higher than 17.
- *Delivery without lower part for assembling as Top Load with tool no. 799.350.475

d [mm]	d1 [mm]	Code	GP	kg	d2 [mm]	H [mm]	H1 [mm]	L [mm]	L1 [mm]	z [mm]
63	20	193 131 402	3	0.695	32	186	108	165	71	130
63	25	193 131 403	3	0.713	32	186	108	165	71	130
63	32	193 131 404	3	0.715	32	186	108	165	76	130
63	40	193 131 405	3	0.731	32	186	108	165	81	137
63	63	193 131 437	5	1.455	32	134	112	165	100	160
75	20	193 131 442	3	0.825	32	191	113	165	71	130
75	25	193 131 443	3	0.839	32	191	113	165	71	130
75	32	193 131 444	3	0.841	32	191	113	165	76	130
75	40	193 131 445	3	0.858	32	191	113	165	81	137
75	63	193 131 447	5	1.579	32	240	118	165	100	160
90	20	193 131 452	3	0.791	32	199	121	165	71	130
90	25	193 131 453	3	0.802	32	199	121	165	71	130
90	32	193 131 454	3	0.801	32	199	121	165	76	130
90	40	193 131 455	3	0.819	32	199	121	165	81	137
90	63	193 131 457	5	1.541	32	248	126	165	100	160
110	20	193 131 462	3	0.853	32	209	131	165	71	130
110	25	193 131 463	3	0.860	32	209	131	165	71	130
110	32	193 131 464	3	0.860	32	209	131	165	76	130
110	40	193 131 465	3	0.877	32	209	131	165	81	137
110	63	193 131 467	3	1.590	35	258	136	165	100	160
125	20	193 131 472	3	0.879	32	216	138	165	71	130
125	25	193 131 473	4	0.883	32	216	138	165	71	130
125	32	193 131 474	3	0.889	32	216	138	165	76	130
125	40	193 131 475	3	0.906	32	216	138	165	81	137
125	63	193 131 477	3	1.623	35	265	143	165	100	160
140	20	193 131 482	3	0.887	32	233	146	165	71	130
140	25	193 131 483	3	0.884	32	233	146	165	71	130
140	32	193 131 484	3	0.900	32	233	146	165	76	130
140	40	193 131 485	3	0.920	32	233	146	165	81	137
140	63	193 131 487	3	1.639	35	273	151	165	100	160
160	20	193 131 492	3	0.886	32	243	156	165	71	130
160	25	193 131 493	3	0.896	32	243	156	165	71	130
160	32	193 131 494	3	0.896	32	243	156	165	76	130
160	40	193 131 495	3	0.920	32	243	156	165	81	137
160	63	193 131 497	3	1.636	35	283	161	165	100	160
180	20	193 131 502	3	1.002	32	244	166	165	71	130
180	25	193 131 503	3	1.002	32	244	166	165	71	130
180	32	193 131 504	5	1.002	32	244	166	165	76	130
180	40	193 131 505	3	1.022	32	244	166	165	81	137
180	63	193 131 507	3	1.742	35	293	171	165	100	160
200	20	193 131 512	3	1.011	32	254	176	165	71	137
200	25	193 131 513	5	1.011	32	254	176	165	71	130
200	32	193 131 514	3	1.021	32	254	176	165	76	130
200	40	193 131 515	3	1.041	32	254	176	165	81	137
200	63	193 131 517	3	1.761	35	303	181	165	100	160
225	20	193 131 522	3	1.014	32	266	188	165	71	130
225	25	193 131 523	3	1.014	32	266	188	165	71	130
225	32	193 131 524	3	1.014	32	266	188	165	76	130

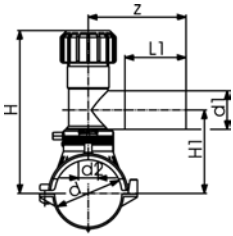

L = length / Länge

PF 2 51 313 001

d [mm]	d1 [mm]	Code	GP	kg	d2 [mm]	H [mm]	H1 [mm]	L [mm]	L1 [mm]	z [mm]	
225	40	193 131 525	5	1.043	32	266	188	165	81	137	
225	63	193 131 527	3	1.763	35	315	193	165	100	160	
250	20	193 131 532	3	1.025	32	279	201	165	76	130	
250	25	193 131 533	3	1.035	32	279	201	165	76	130	
250	32	193 131 534	3	1.035	32	279	201	165	76	130	
250	40	193 131 535	3	1.055	32	279	201	165	81	137	
250	63	193 131 537	3	1.775	35	328	206	165	100	160	
*280	63	193 131 547	5	1.240	35	328	206	165	100	160	
*315-400	63	193 131 557	5	1.513	35	328	206	165	100	160	

Tapping Saddle (Kit) with 360° rotatable outlet

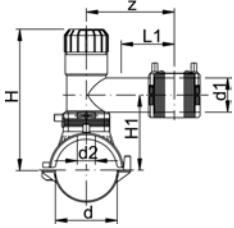

- PE 100 SDR 11 (ISO S5)
- 10 bar Gas / 16 bar Water
- With integrated cutter to tap live mains under pressure
- Complete with lower part
- 4 mm pin connectors
- Limited path fusion indicators
- Long fusion outlet
- O-ring sealed screw-cap
- Supplied as Kit with enclosed service line fitting (ELGEF® Plus Coupler or Reducer)
- D 315 - 400 mm: application is limited on pipes d 355 and d 400 mm. Not suitable for pipes with an SDR value higher than 17.
- *Delivery without lower part for assembling as Top Load with tool no. 799.350.475

d [mm]	d1 [mm]	Code	GP	kg	d2 [mm]	H [mm]	H1 [mm]	L [mm]	L1 [mm]	z [mm]
63	20	193 132 402	3	0.749	32	186	108	165	76	130
63	25	193 132 403	3	0.773	32	186	108	165	76	130
63	32	193 132 404	3	0.787	32	186	108	165	76	130
63	40	193 132 405	3	0.831	32	186	108	165	76	130
63	50	193 132 436	5	1.651	32	234	112	165	100	160
63	63	193 132 437	5	1.649	32	234	112	165	100	160
75	20	193 132 442	3	0.879	32	191	113	165	76	130
75	25	193 132 443	3	0.900	32	191	113	165	76	130
75	32	193 132 444	3	0.913	32	191	113	165	76	130
75	40	193 132 445	3	0.958	32	240	118	165	76	160
75	50	193 132 446	5	1.775	32	240	118	165	100	160
75	63	193 132 447	5	1.773	32	240	118	165	100	160
90	20	193 132 452	3	0.845	32	199	121	165	76	130
90	25	193 132 453	3	0.862	32	199	121	165	76	130
90	32	193 132 454	3	0.875	32	199	121	165	76	130
90	40	193 132 455	3	0.919	32	199	126	165	76	130
90	50	193 132 456	5	1.737	32	248	126	165	100	160
90	63	193 132 457	5	1.735	32	248	126	165	100	160
110	20	193 132 462	3	0.907	32	209	131	165	76	130
110	25	193 132 463	3	0.920	32	209	131	165	76	130
110	32	193 132 464	3	0.932	32	209	131	165	76	130
110	40	193 132 465	3	0.977	32	209	136	165	76	130
110	50	193 132 466	3	1.786	35	258	136	165	100	160
110	63	193 132 467	3	1.784	35	258	136	165	100	160
125	20	193 132 472	3	0.933	32	216	138	165	76	130
125	25	193 132 473	3	0.943	32	216	138	165	76	130
125	32	193 132 474	3	0.961	32	216	138	165	76	130
125	40	193 132 475	3	1.006	32	216	143	165	76	130
125	50	193 132 476	3	1.819	35	256	143	165	100	160
125	63	193 132 477	3	1.817	35	256	143	165	100	160
140	20	193 132 482	3	0.941	32	234	146	165	76	130
140	25	193 132 483	3	0.944	32	234	146	165	76	130
140	32	193 132 484	3	0.972	32	234	146	165	76	130
140	40	193 132 485	3	1.020	32	234	146	165	76	130
140	50	193 132 486	3	1.835	35	283	151	165	100	160
140	63	193 132 487	3	1.833	35	283	151	165	100	160
160	20	193 132 492	3	0.940	32	234	156	165	76	130
160	25	193 132 493	3	0.956	32	234	156	165	76	130
160	32	193 132 494	3	0.968	32	234	156	165	76	130
160	40	193 132 495	3	1.016	32	234	161	165	76	130
160	50	193 132 496	3	1.832	35	283	161	165	100	160
160	63	193 132 497	3	1.830	35	283	161	165	100	160
180	20	193 132 502	3	1.020	32	244	166	165	71	130
180	25	193 132 503	3	1.210	32	244	166	165	71	130
180	32	193 132 504	3	1.074	32	244	166	165	76	130
180	40	193 132 505	3	1.122	32	244	171	165	76	130

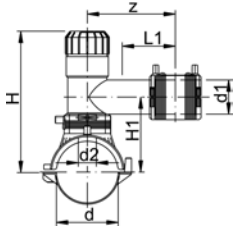

d [mm]	d1 [mm]	Code	GP	kg	d2 [mm]	H [mm]	H1 [mm]	L [mm]	L1 [mm]	z [mm]
180	50	193 132 506	3	1.938	35	293	171	165	100	160
180	63	193 132 507	3	1.936	35	293	171	165	100	160
200	20	193 132 512	3	1.065	32	254	176	165	76	130
200	25	193 132 513	3	1.065	32	254	176	165	71	130
200	32	193 132 514	3	1.093	32	254	176	165	76	130
200	40	193 132 515	3	1.141	32	254	181	165	76	130
200	50	193 132 516	3	1.957	35	303	181	165	100	160
200	63	193 132 517	3	1.955	35	303	181	165	100	160
225	20	193 132 522	3	1.460	32	266	188	165	71	130
225	25	193 132 523	3	1.460	32	266	188	165	71	130
225	32	193 132 524	3	1.086	32	266	188	165	76	130
225	40	193 132 525	3	1.143	32	266	193	165	76	130
225	50	193 132 526	3	1.959	35	315	193	165	100	160
225	63	193 132 527	3	1.957	35	315	193	165	100	160
250	20	193 132 532	5	1.079	32	279	201	165	76	130
250	25	193 132 533	3	1.095	32	279	201	165	76	130
250	32	193 132 534	3	1.107	32	279	201	165	76	130
250	40	193 132 535	3	1.155	32	279	206	165	76	160
250	50	193 132 536	3	1.971	35	328	206	165	100	160
250	63	193 132 537	3	1.969	35	328	206	165	100	160
*280	32	193 132 544	3	1.460	35	328	206	165	100	160
*280	40	193 132 545	3	1.500	35	328	206	165	100	160
*280	50	193 132 546	5	1.500	35	328	206	165	100	160
*280	63	193 132 547	5	1.510	35	328	206	165	100	160
*315 - 400	32	193 132 554	5	1.015	35	328	206	165	100	160
*315 - 400	40	193 132 555	5	1.015	35	328	206	165	100	160
*315 - 400	50	193 132 556	5	1.440	35	328	206	165	100	160
*315 - 400	63	193 132 557	5	1.450	35	328	206	165	100	160

PF 2 51 313 001

53 130 600

Tapping Saddle with Gas-Stop Type 1-5 bar with 360° rotatable outlet

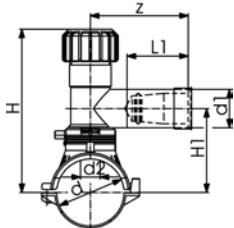

L = length / Länge

- PE 100 SDR 11 (ISO S5)
- 5 bar Gas (for pressure 1 bar -5 bar)
- With integrated cutter to tap live mains under pressure
- Gas-Stop System Pipelife (GS 20/1, GS 32/1, GS 63/1)
- **Without overflow orifice**
- Set comes with Gas-Stop pre-assembled
- Installation instructions of Gas-Stop manufacturer are to be observed
- Complete with lower part
- 4 mm pin connectors
- Limited path fusion indicators
- Long fusion outlet
- O-ring sealed screw-cap

d [mm]	d1 [mm]	Code	GP	kg	d2 [mm]	H [mm]	H1 [mm]	L [mm]	L1 [mm]	z [mm]	Vn max [m³/h]
63	63	193 281 159	5	1.556	32	134	112	165	100	160	280
90	20	193 281 435	3	0.728	25	199	121	165	71	130	25
90	32	193 281 154	3	0.728	25	199	121	165	76	130	100
90	63	193 281 160	5	1.642	32	248	126	165	100	160	280
110	20	193 281 437	3	0.873	25	209	131	165	71	130	25
110	32	193 281 155	3	0.873	25	209	131	165	76	130	100
110	63	193 281 161	3	1.691	35	258	136	165	100	160	280
125	20	193 281 438	3	0.902	25	216	138	165	71	130	25
125	32	193 281 156	3	0.902	25	216	138	165	76	130	100
125	63	193 281 162	3	1.724	35	265	143	165	100	160	280
160	20	193 281 439	3	0.909	25	243	156	165	71	130	25
160	32	193 281 157	3	0.909	25	243	156	165	76	130	100
160	63	193 281 163	3	1.737	35	283	161	165	100	160	280
225	20	193 281 122	3	1.011	25	266	188	165	71	130	25
225	32	193 281 158	3	1.011	25	266	188	165	76	130	100
225	63	193 281 164	3	1.864	35	315	193	165	100	160	280

PF 2 51 313 003

Tapping Saddle with Gas-Stop Type AD UE with 360° rotatable outlet

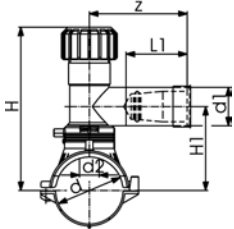

L = length / Länge

- PE 100 SDR 11 (ISO S5)
- 1 bar Gas (for pressure **25 mbar - 1 bar**)
- With integrated cutter to tap live mains under pressure
- Gas-Stop System Pipelife Type AD (GS 32/25 UE or GS 63/25 UE)
- **With overflow orifice**
- Set comes with Gas-Stop pre-assembled
- Installation instructions of Gas-Stop manufacturer are to be observed
- Complete with lower part
- 4 mm pin connectors
- Limited path fusion indicators
- Long fusion outlet
- O-ring sealed screw-cap

d	d1	Code	GP	kg	d2	H	H1	L	L1	z	Vn max	
[mm]	[mm]				[mm]	[mm]	[mm]	[mm]	[mm]	[mm]	[m ³ /h]	
63	32	193 130 604	3	0.728	32	186	108	165	76	130	10	
63	63	193 130 637	5	1.556	32	134	112	165	100	160	40	
75	32	193 130 644	3	0.854	32	191	113	165	76	130	10	
75	63	193 130 647	5	1.680	32	240	118	165	100	160	40	
90	32	193 130 654	3	0.814	32	199	121	165	76	130	10	
90	63	193 130 657	5	1.642	32	248	126	165	100	160	40	
110	32	193 130 664	3	0.873	32	209	131	165	76	130	10	
110	63	193 130 667	3	1.691	35	258	136	165	100	160	40	
125	32	193 130 674	3	0.902	32	216	138	165	76	130	10	
125	63	193 130 677	3	1.724	35	265	143	165	100	160	40	
140	32	193 130 684	3	0.913	32	233	146	165	76	130	10	
140	63	193 130 687	3	1.740	35	273	151	165	100	160	40	
160	32	193 130 694	3	0.909	32	243	156	165	76	130	10	
160	63	193 130 697	3	1.737	35	283	161	165	100	160	40	
180	32	193 130 704	3	1.015	32	244	166	165	76	130	10	
180	63	193 130 707	3	1.843	35	293	171	165	100	160	40	
200	32	193 130 714	3	1.034	32	254	176	165	76	130	10	
200	63	193 130 717	3	1.862	35	303	181	165	100	160	40	
225	32	193 130 724	3	1.027	32	266	188	165	76	130	10	
225	63	193 130 727	3	1.864	35	315	193	165	100	160	40	
250	32	193 130 734	3	1.048	32	279	201	165	76	130	10	
250	63	193 130 737	3	1.876	35	328	206	165	100	160	40	

PF 2 51 313 003

Tapping Saddle with Gas-Stop Type B UE with 360° rotatable outlet

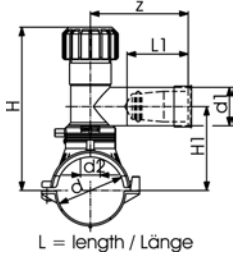

- PE 100 SDR 11 (ISO S5)
- 5 bar Gas (for pressure **150 mbar - 5 bar**)
- With integrated cutter to tap live mains under pressure
- Gas-Stop System Pipelife Type B (GS 32/150 UE or GS 63/150 UE)
- **With overflow orifice**
- Set comes with Gas-Stop pre-assembled
- Installation instructions of Gas-Stop manufacturer are to be observed
- Complete with lower part
- 4 mm pin connectors
- Limited path fusion indicators
- Long fusion outlet
- O-ring sealed screw-cap

d	d1	Code	GP	kg	d2	H	H1	L	L1	z	Vn max	
[mm]	[mm]				[mm]	[mm]	[mm]	[mm]	[mm]	[mm]	[m ³ /h]	
63	32	193 130 804	3	0.728	32	186	108	165	76	130	45	
63	63	193 130 837	5	1.556	32	134	112	165	100	160	180	
75	32	193 130 844	5	0.854	32	191	113	165	76	130	45	
75	63	193 130 847	5	1.680	32	240	118	165	100	160	180	
90	32	193 130 854	3	0.814	32	199	121	165	76	130	45	
90	63	193 130 857	5	1.642	32	248	126	165	100	160	180	
110	32	193 130 864	3	0.873	32	209	131	165	76	130	45	
110	63	193 130 867	3	1.691	35	258	136	165	100	160	180	
125	32	193 130 874	3	0.902	32	216	138	165	76	130	45	
125	63	193 130 877	3	1.724	35	265	143	165	100	160	180	
140	32	193 130 884	3	0.913	32	233	146	165	76	130	45	
140	63	193 130 887	3	1.740	35	273	151	165	100	160	180	
160	32	193 130 894	3	0.909	32	243	156	165	76	130	45	
160	63	193 130 897	3	1.737	35	283	161	165	100	160	180	
180	32	193 130 904	3	1.015	32	244	166	165	76	130	45	
180	63	193 130 907	3	1.843	35	293	171	165	100	160	180	
200	32	193 130 914	3	1.034	32	254	176	165	76	130	45	
200	63	193 130 917	3	1.862	35	303	181	165	100	160	180	
225	32	193 130 924	3	1.027	32	266	188	165	76	130	45	
225	63	193 130 927	3	1.864	35	315	193	165	100	160	180	
250	32	193 130 934	3	1.048	32	279	201	165	76	130	45	
250	63	193 130 937	3	1.876	35	328	206	165	100	160	180	

PF 2 51 313 003

Pressure Tapping Valve System P - Punching drill with 360° rotatable outlet

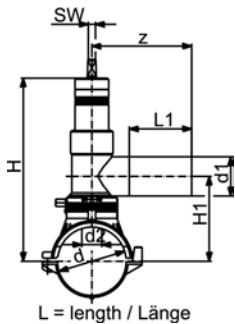

- PE 100 SDR 11 (ISO S5)
- 10 bar Gas / 16 bar Water
- With integrated puncher to tap live mains under pressure
- Complete with lower part and premounted PE100 coated valve piece
- The valve is closed clockwise
- Number of turns to fully open or close valve is 28 for outlet d 63
- Number of turns to fully open or close valve is 13 for outlet d 32
- Opening of the spanner (SW) is 14
- 4 mm pin connectors
- Limited path fusion indicators
- Long fusion outlet

d	d1	Code	GP	kg	d2	H	H1	L	L1	z
[mm]	[mm]				[mm]	[mm]	[mm]	[mm]	[mm]	[mm]
63	32	193 152 234	5	2.935	21	202	97	165	70	127
63	63	193 152 237	5	2.935	30	272	112	165	100	160
75	32	193 152 244	5	3.065	21	208	103	165	70	127
75	63	193 152 247	5	3.065	30	278	118	165	100	160
90	32	193 152 254	5	3.025	21	216	111	165	70	127
90	63	193 152 257	5	3.025	30	286	126	165	100	160
110	32	193 152 264	3	3.093	21	226	121	165	70	127
110	63	193 152 267	3	3.093	30	296	136	165	100	160
125	32	193 152 274	3	3.123	21	233	128	165	70	127
125	63	193 152 277	3	3.123	30	303	143	165	100	160
140	32	193 152 284	3	3.123	21	241	136	165	70	127
140	63	193 152 287	3	3.123	30	311	151	165	100	160
160	32	193 152 294	3	3.126	21	251	146	165	70	127
160	63	193 152 297	3	3.126	30	321	161	165	100	160
180	32	193 152 304	3	3.232	21	261	156	165	70	127
180	63	193 152 307	3	3.232	30	331	171	165	100	160
200	32	193 152 314	3	3.251	21	271	166	165	70	127
200	63	193 152 317	3	3.251	30	341	181	165	100	160
225	32	193 152 324	3	3.253	21	281	178	165	70	127
225	63	193 152 327	3	3.253	30	353	193	165	100	160

PF 2 51 313 004

Pressure Tapping Valve System P - Punching drill with 360° rotatable outlet

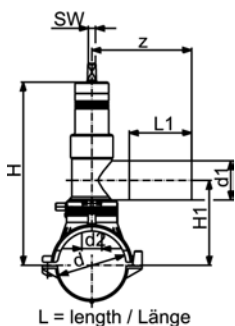

- PE 100 SDR 17 (ISO S8)
- 10 bar Gas / 16 bar Water
- With integrated puncher to tap live mains under pressure
- **Not suitable for pipes with an SDR value higher than 17.**
- Complete with lower part and premounted PE100 coated valve piece
- The valve is closed clockwise
- Number of turns to fully open or close valve is 28 for outlet d 63
- Number of turns to fully open or close valve is 13 for outlet d 32
- Opening of the spanner (SW) is 14
- 4 mm pin connectors
- Limited path fusion indicators
- Long fusion outlet
- D 315 - 400 mm: application is limited on pipes d 400 mm. Not suitable for pipes with an SDR value higher than 26.
- *Delivery without lower part for assembling as Top Load with tool no. 799.350.475

d	d1	Code	GP	kg	d2	H	H1	L	L1	z
[mm]	[mm]				[mm]	[mm]	[mm]	[mm]	[mm]	[mm]
250	32	193 152 334	3	3.000	21	293	191	165	70	127
250	63	193 152 337	3	3.000	30	366	206	165	100	160
*280	32	193 152 344	3	3.000	21	293	191	165	70	127
*280	63	193 152 347	3	3.000	30	366	206	165	100	160
*315 - 400	32	193 152 354	3	3.000	21	293	191	165	70	127
*315 - 400	63	193 152 357	3	3.000	30	366	206	165	100	160

PF 2 51 313 004

Pressure Tapping Valve (Kit) System P - Punching drill with 360° rotatable outlet

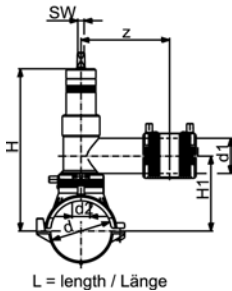

- PE 100 SDR 11 (ISO S5)
- 10 bar Gas / 16 bar Water
- With integrated puncher to tap live mains under pressure
- Complete with lower part and premounted PE100 coated valve piece
- The valve is closed clockwise
- Number of turns to fully open or close valve is 28 for outlet d 40, d 50, d 63
- Number of turns to fully open or close valve is 13 for outlet d 32
- Opening of the spanner (SW) is 14
- 4 mm pin connectors
- Limited path fusion indicators
- Long fusion outlet
- Supplied as Kit with enclosed service line fitting (ELGEF® Plus Coupler or Reducer)

d	d1	Code	GP	kg	d2	H	H1	L	z
[mm]	[mm]				[mm]	[mm]	[mm]	[mm]	[mm]
63	32	193 152 034	5	3.113	21	202	97	165	127
63	40	193 152 035	5	3.119	30	272	112	165	160
63	50	193 152 036	5	3.131	30	272	112	165	160
63	63	193 152 037	5	3.129	30	272	112	165	160
75	32	193 152 044	3	3.243	21	208	103	165	127
75	40	193 152 045	3	3.249	30	278	118	165	160
75	50	193 152 046	5	3.261	30	278	118	165	160
75	63	193 152 047	1	3.259	30	278	118	165	160
90	32	193 152 054	5	3.203	21	216	111	165	127
90	40	193 152 055	5	3.209	30	286	126	165	160
90	50	193 152 056	5	3.215	30	286	126	165	160
90	63	193 152 057	5	3.213	30	286	126	165	160
110	32	193 152 064	3	3.241	21	226	121	165	127
110	40	193 152 065	3	3.247	30	296	136	165	160
110	50	193 152 066	3	3.253	30	296	136	165	160
110	63	193 152 067	3	3.251	30	296	136	165	160
125	32	193 152 074	3	3.271	21	233	128	165	127
125	40	193 152 075	3	3.307	30	303	143	165	160
125	50	193 152 076	3	3.319	30	303	143	165	160
125	63	193 152 077	3	3.317	30	303	143	165	160
140	32	193 152 084	1	3.301	21	241	136	165	127
140	40	193 152 085	3	3.307	30	311	151	165	160
140	50	193 152 086	3	3.315	30	311	151	165	160
140	63	193 152 087	1	3.313	30	311	151	165	160
160	32	193 152 094	3	3.304	21	251	146	165	127
160	40	193 152 095	3	3.310	30	321	161	165	160
160	50	193 152 096	3	3.318	30	321	161	165	160
160	63	193 152 097	3	3.308	30	321	161	165	160
180	32	193 152 104	3	3.410	21	261	156	165	127
180	40	193 152 105	3	3.416	30	331	171	165	160
180	50	193 152 106	3	3.424	30	331	171	165	160
180	63	193 152 107	3	3.426	30	331	171	165	160
200	32	193 152 114	3	3.431	21	271	166	165	127
200	40	193 152 115	1	3.435	30	341	181	165	160
200	50	193 152 116	3	3.453	30	341	181	165	160
200	63	193 152 117	1	3.451	30	341	181	165	160
225	32	193 152 124	3	3.431	21	281	178	165	127
225	40	193 152 125	3	3.437	30	353	193	165	160
225	50	193 152 126	3	3.445	30	353	193	165	160
225	63	193 152 127	3	3.443	30	353	193	165	160

PF 2 51 313 004

Pressure Tapping Valve (Kit) System P - Punching drill with 360° rotatable outlet

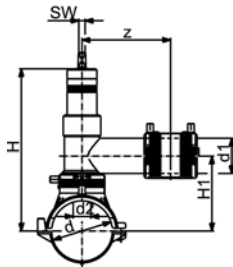

L = length / Länge

- PE 100 SDR 17 (ISO S8)
- 10 bar Gas / 16 bar Water
- With integrated puncher to tap live mains under pressure
- **Not suitable for pipes with an SDR value higher than 17.**
- Complete with lower part and premounted PE100 coated valve piece
- The valve is closed clockwise
- Number of turns to fully open or close valve is 28 for outlet d 40, d 50, d 63
- Number of turns to fully open or close valve is 13 for outlet d 32
- Opening of the spanner (SW) is 14
- 4 mm pin connectors
- Limited path fusion indicators
- Long fusion outlet
- Supplied as Kit with enclosed service line fitting (ELGEF® Plus Coupler or Reducer)
- D 315 - 400 mm: application is limited on pipes d 400 mm. Not suitable for pipes with an SDR value higher than 26.
- *Delivery without lower part for assembling as Top Load with tool no. 799.350.475

d [mm]	d1 [mm]	Code	GP	kg	d2 [mm]	H [mm]	H1 [mm]	L [mm]	z [mm]
250	32	193 152 134	3	3.443	21	293	191	165	127
250	40	193 152 135	3	3.449	30	366	206	165	160
250	50	193 152 136	1	3.457	30	366	206	165	160
250	63	193 152 137	1	3.455	30	366	206	165	160
*280	32	193 152 144	5	3.118	21	293	191	165	127
*280	40	193 152 145	5	3.124	30	366	206	165	160
*280	50	193 152 146	5	3.136	30	366	206	165	160
*280	63	193 152 147	5	3.134	30	366	206	165	160
*315 - 400	32	193 152 154	5	3.118	21	293	191	165	127
*315 - 400	40	193 152 155	5	3.124	30	366	206	165	160
*315 - 400	50	193 152 156	3	3.136	30	366	206	165	160
*315 - 400	63	193 152 157	5	3.134	30	366	206	165	160

PF 2 51 313 004

53 154 200

Pressure Tapping Valve System C - Cutting drill with 360° rotatable outlet

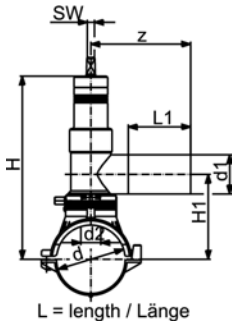

- PE 100 SDR 11 (ISO S5)
- 10 bar Gas / 16 bar Water
- With integrated cutter to tap live mains under pressure
- Complete with lower part and premounted PE100 coated valve piece
- The valve is closed clockwise
- Number of turns to fully open or close valve is 22 for outlet d 63
- Number of turns to fully open or close valve is 13 for outlet d 75
- Opening of the spanner (SW) is 14
- 4 mm pin connectors
- Limited path fusion indicators
- Long fusion outlet

d	d1	Code	GP	kg	d2	H	H1	L	L1	z
[mm]	[mm]				[mm]	[mm]	[mm]	[mm]	[mm]	[mm]
63	32	193 154 234	5	1.635	27	202	97	165	70	127
63	63	193 154 237	5	2.740	33	272	112	165	100	160
75	32	193 154 244	5	1.765	27	208	103	165	70	127
75	63	193 154 247	5	2.870	33	278	118	165	100	160
90	32	193 154 254	5	1.725	27	216	111	165	70	127
90	63	193 154 257	5	2.830	33	286	126	165	100	160
110	32	193 154 264	3	1.793	27	226	121	165	70	127
110	63	193 154 267	3	2.900	33	296	136	165	100	160
125	32	193 154 274	3	1.823	27	233	128	165	70	127
125	63	193 154 277	3	2.930	33	303	143	165	100	160
140	32	193 154 284	3	1.823	27	241	136	165	70	127
140	63	193 154 287	3	2.930	33	311	151	165	100	160
160	32	193 154 294	3	1.826	27	251	146	165	70	127
160	63	193 154 297	3	2.930	33	321	161	165	100	160
180	32	193 154 304	3	1.932	27	261	156	165	70	127
180	63	193 154 307	3	3.037	33	331	171	165	100	160
200	32	193 154 314	3	1.951	27	271	166	165	70	127
200	63	193 154 317	3	3.056	33	341	181	165	100	160
225	32	193 154 324	3	1.953	27	281	178	165	70	127
225	63	193 154 327	4	3.058	33	353	193	165	100	160

PF 2 51 313 002

53 154 300

Pressure Tapping Valve System C - Cutting drill with 360° rotatable outlet

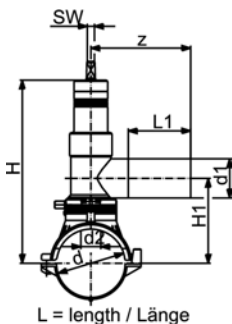

- PE 100 SDR 17 (ISO S8)
- 10 bar Gas / 16 bar Water
- With integrated cutter to tap live mains under pressure
- **Not suitable for pipes with an SDR value higher than 17.**
- Complete with lower part and premounted PE100 coated valve piece
- The valve is closed clockwise
- Number of turns to fully open or close valve is 22 for outlet d 63
- Number of turns to fully open or close valve is 13 for outlet d 32
- Opening of the spanner (SW) is 14
- 4 mm pin connectors
- Limited path fusion indicators
- Long fusion outlet
- D 315 - 400 mm: application is limited on pipes d 400 mm. Not suitable for pipes with an SDR value higher than 26.
- *Delivery without lower part for assembling as Top Load with tool no. 799.350.475

d	d1	Code	GP	kg	d2	H	H1	L	L1	z	
[mm]	[mm]				[mm]	[mm]	[mm]	[mm]	[mm]	[mm]	
	250	32	193 154 334	3	1.700	27	293	191	165	70	127
	250	63	193 154 337	3	3.070	33	366	206	165	100	160
	*280	32	193 154 344	3	1.700	27	293	191	165	70	127
	*280	63	193 154 347	3	2.800	33	366	206	165	100	160
	*315 - 400	32	193 154 354	3	1.700	27	293	191	165	70	127
	*315 - 400	63	193 154 357	3	2.800	33	366	206	165	100	160

PF 2 51 313 002

Pressure Tapping Valve (Kit) System C - Cutting drill with 360° rotatable outlet

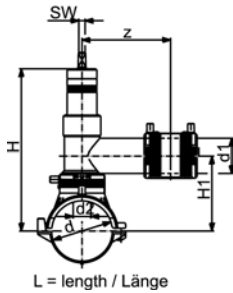

- PE 100 SDR 11 (ISO S5)
- 10 bar Gas / 16 bar Water
- With integrated cutter to tap live mains under pressure
- Complete with lower part and premounted PE100 coated valve piece
- The valve is closed clockwise
- Number of turns to fully open or close valve is 22 for outlet d 40, d 50, d 63
- Number of turns to fully open or close valve is 13 for outlet d 32
- Opening of the spanner (SW) is 14
- 4 mm pin connectors
- Limited path fusion indicators
- Long fusion outlet
- Supplied as Kit with enclosed service line fitting (ELGEF® Plus Coupler or Reducer)

d	d1	Code	GP	kg	d2	H	H1	L	z
[mm]	[mm]				[mm]	[mm]	[mm]	[mm]	[mm]
63	32	193 154 034	5	1.618	27	202	97	165	127
63	40	193 154 035	5	2.924	33	272	112	165	160
63	50	193 154 036	5	2.936	33	272	112	165	160
63	63	193 154 037	5	2.934	33	272	112	165	160
75	32	193 154 044	5	1.748	27	208	103	165	127
75	40	193 154 045	5	3.054	33	278	118	165	160
75	50	193 154 046	5	3.066	33	278	118	165	160
75	63	193 154 047	5	3.064	33	278	118	165	160
90	32	193 154 054	5	1.708	27	216	111	165	127
90	40	193 154 055	5	3.014	33	286	126	165	160
90	50	193 154 056	5	3.026	33	286	126	165	160
90	63	193 154 057	5	3.024	33	286	126	165	160
110	32	193 154 064	3	1.776	27	226	121	165	127
110	40	193 154 065	3	3.082	33	296	136	165	160
110	50	193 154 066	3	3.094	33	296	136	165	160
110	63	193 154 067	3	3.092	33	296	136	165	160
125	32	193 154 074	3	1.806	27	233	128	165	127
125	40	193 154 075	3	3.112	33	303	143	165	160
125	50	193 154 076	3	3.124	33	303	143	165	160
125	63	193 154 077	3	3.122	33	303	143	165	160
140	32	193 154 084	3	1.806	27	241	136	165	127
140	40	193 154 085	3	3.112	33	311	151	165	160
140	50	193 154 086	3	3.124	33	311	151	165	160
140	63	193 154 087	3	3.122	33	311	151	165	160
160	32	193 154 094	3	1.809	27	251	146	165	127
160	40	193 154 095	3	3.115	33	321	161	165	160
160	50	193 154 096	3	3.127	33	321	161	165	160
160	63	193 154 097	3	3.125	33	321	161	165	160
180	32	193 154 104	3	1.915	27	262	156	165	127
180	40	193 154 105	3	3.221	33	331	171	165	160
180	50	193 154 106	3	3.233	33	331	171	165	160
180	63	193 154 107	3	3.231	33	331	171	165	160
200	32	193 154 114	3	1.934	27	271	166	165	127
200	40	193 154 115	3	3.240	33	341	181	165	160
200	50	193 154 116	3	3.252	33	341	181	165	160
200	63	193 154 117	3	3.250	33	341	181	165	160
225	32	193 154 124	4	1.936	27	283	178	165	127
225	40	193 154 125	3	3.242	33	353	193	165	160
225	50	193 154 126	3	3.254	33	353	193	165	160
225	63	193 154 127	3	3.252	33	353	193	165	160

Pressure Tapping Valve (Kit) System C - Cutting drill with 360° rotatable outlet

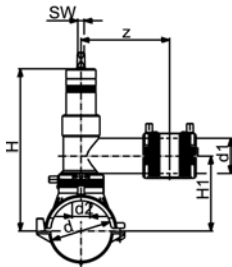

L = length / Länge

- PE 100 SDR 17 (ISO S8)
- 10 bar Gas / 16 bar Water
- With integrated cutter to tap live mains under pressure
- **Not suitable for pipes with an SDR value higher than 17.**
- Complete with lower part and premounted PE100 coated valve piece
- The valve is closed clockwise
- Number of turns to fully open or close valve is 22 for outlet d 40, d 50, d 63
- Number of turns to fully open or close valve is 13 for outlet d 32
- Opening of the spanner (SW) is 14
- 4 mm pin connectors
- Limited path fusion indicators
- Long fusion outlet
- Supplied as kit with enclosed service line fitting (ELGEF® Plus Coupler or Reducer)
- D 315 - 400 mm: application is limited on pipes d 400 mm. Not suitable for pipes with an SDR value higher than 26.
- *Delivery without lower part for assembling as Top Load with tool no. 799.350.475

d [mm]	d1 [mm]	Code	GP	kg	d2 [mm]	H [mm]	H1 [mm]	L [mm]	z [mm]
250	32	193 154 134	3	1.948	27	296	191	165	127
250	40	193 154 135	3	3.254	33	366	206	165	160
250	50	193 154 136	3	3.266	33	366	206	165	160
250	63	193 154 137	3	3.264	33	366	206	165	160
*280	32	193 154 144	5	1.670	27	296	191	165	127
*280	40	193 154 145	5	2.975	33	366	206	165	160
*280	50	193 154 146	5	2.990	33	366	206	165	160
*280	63	193 154 147	5	2.990	33	366	206	165	160
*315 - 400	32	193 154 154	3	1.670	27	296	191	165	127
*315 - 400	40	193 154 155	3	2.975	33	366	206	165	160
*315 - 400	50	193 154 156	3	2.990	33	366	206	165	160
*315 - 400	63	193 154 157	3	2.990	33	366	206	165	160

PF 2 51 313 002

53 131 200

Spigot Saddle with Cutter

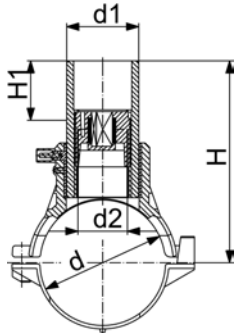

L = length / Länge

- PE 100 SDR 11 (ISO S5)
- 10 bar Gas / 16 bar Water
- Complete with lower part
- 4 mm pin connectors
- Limited path fusion indicators
- D 315 - 400 mm: application is limited on pipes d 355 and d 400 mm. Not suitable for pipes with an SDR value higher than 17.
- *Delivery without lower part for assembling as Top Load with tool no. 799.350.475

d [mm]	d1 [mm]	Code	GP	kg	d2 [mm]	H [mm]	H1 [mm]	L [mm]	SW [mm]
63	32	193 131 234	5	0.538	19	145	50	165	13
63	63	193 131 237	5	1.036	32	152	50	165	17
75	32	193 131 244	5	0.668	19	151	50	165	13
75	63	193 131 247	5	1.166	32	158	50	165	17
90	32	193 131 254	5	0.628	19	158	50	165	13
90	63	193 131 257	5	1.126	32	165	50	165	17
110	32	193 131 264	3	0.696	19	168	50	165	13
110	63	193 131 267	5	1.194	32	175	50	165	17
125	32	193 131 274	5	0.726	19	176	50	165	13
125	63	193 131 277	5	1.224	32	183	50	165	17
140	32	193 131 284	5	0.726	19	183	50	165	13
140	63	193 131 287	3	1.224	32	190	50	165	17
160	32	193 131 294	5	0.729	19	193	50	165	13
160	63	193 131 297	5	1.227	32	200	50	165	17
180	32	193 131 304	5	0.835	19	203	50	165	13
180	63	193 131 307	5	1.333	32	210	50	165	17
200	32	193 131 314	1	0.854	19	213	50	165	13
200	63	193 131 317	1	1.352	32	220	50	165	17
225	32	193 131 324	5	0.856	19	226	50	165	13
225	63	193 131 327	5	1.354	32	233	50	165	17
250	32	193 131 334	5	0.868	19	238	50	165	13
250	63	193 131 337	5	1.366	32	245	50	165	17
*280	63	193 131 347	5	0.830	35	245	50	165	17
PF 2 51 313 001	*315 - 400	63 193 131 357	5	0.830	35	245	50	165	17

53 130 200

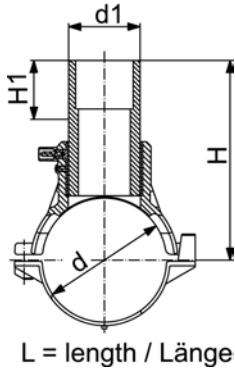

Spigot Saddle

- PE 100 SDR 11 (ISO S5)
- 10 bar Gas / 16 bar Water
- Complete with lower part
- 4 mm pin connectors
- Limited path fusion indicators
- D 315 - 400 mm: application is limited on pipes d 355 and d 400 mm. Not suitable for pipes with an SDR value higher than 17.
- *Delivery without lower part for assembling as Top Load with tool no. 799.350.475

d [mm]	d1 [mm]	Code	GP	kg	H [mm]	H1 [mm]	L [mm]
63	32	193 130 234	5	0.500	145	50	165
63	63	193 130 237	5	0.630	152	50	165
75	32	193 130 244	5	0.634	151	50	165
75	63	193 130 247	5	0.536	158	50	165
90	32	193 130 254	5	0.590	158	50	165
90	63	193 130 257	5	0.495	165	50	165
110	32	193 130 264	3	0.662	168	50	165
110	63	193 130 267	5	0.564	175	50	165
125	32	193 130 274	5	0.692	176	50	165
125	63	193 130 277	5	0.592	183	50	165
140	32	193 130 284	5	0.692	183	50	165
140	63	193 130 287	3	0.594	190	50	165
160	32	193 130 294	5	0.693	193	50	165
160	63	193 130 297	5	0.597	200	50	165
180	32	193 130 304	5	0.800	203	50	165
180	63	193 130 307	5	0.700	210	50	165
200	32	193 130 314	5	0.820	213	50	165
200	63	193 130 317	5	0.722	220	50	165
225	32	193 130 324	5	0.820	226	50	165
225	63	193 130 327	5	0.724	233	50	165
250	32	193 130 334	5	0.834	238	50	165
250	63	193 130 337	5	0.736	245	50	165
*280	63	193 130 347	5	0.400	245	50	165
*315 - 400	63	193 130 357	5	0.400	245	50	165

PF 2 51 313 001

53 127 000

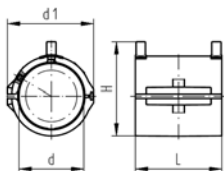

Reinforcing Saddle

- PE 100 SDR 11 (ISO S5)
- 10 bar Gas / 16 bar Water
- Fusion voltage 24 Volt
- 4 mm pin connectors
- For use as a repair saddle with PE repair plug (Code 799.199.088 and 799.199.089) and as
- Reinforcing saddle with an fusion area which extends the whole circumference of the pipe
- Use Spring clamp (Code 799.150.090) for installation

d [mm]	Code	GP	kg	d1 [mm]	L [mm]	H [mm]
40	193 127 017	14	0.140	104	105	108
50	193 127 027	10	0.200	80	105	85
63	193 127 037	8	0.279	132	120	153
75	193 127 047	-	0.430	162	130	122
90	193 127 057	12	0.558	104	130	147
110	193 127 067	12	0.562	120	120	191
125	193 127 077	-	0.710	158	130	184
160	193 127 097	6	0.961	192	130	218
180	193 127 107	-	1.095	214	130	239
200	193 127 117	4	1.250	236	130	260
225	193 127 127	-	1.413	262	140	286

PF 2 51 303 020

60 050 600



PF 2 51 313 017

Rigid Extension Spindle



- PE-casing with anti-sand cap
- PE-sleeve, suitable for tapping valve and service valve (insert needed)
- Square bar steel, hot-dip galvanized
- Clip-pin from stainless steel 1.4301
- Bush CI40 with slot and clip-pin (tool-free connection)

Pipe cover [m]	Code	kg	
0.75	160 050 620	1.200	
1.00	160 050 621	1.592	
1.25	160 050 622	2.031	
1.50	160 050 623	2.448	

60 050 500



PF 2 51 313 017

Telescopic Extension Spindle



- Continuously adjustable and self-supporting
- Pullout- and dirt-safe
- Rod hot-dip galvanized
- PE-casing, PE-centering cap with gasket
- Clip-pin from stainless steel 1.4301
- Bush CI40 with slot and clip-pin (tool-free connection)
- PE-sleeve, suitable for tapping valve and service valve (insert needed)

Pipe cover [m]	Code	kg	
0.75-1.05	160 050 520	2.031	
1.00-1.50	160 050 521	2.500	
1.30-1.90	160 050 522	2.700	
1.70-2.70	160 050 523	2.000	



Stop-off Valves PE 100

Valves

Accessories/Spindles

Extension Spindle

93 103 025

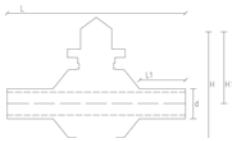
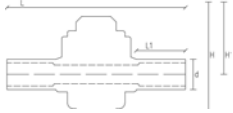

Polyvalve Stop-Off Valve

- PE 100 SDR 11 (ISO S5) - d20 up to d200
- 10 bar Gas / 16 bar Water
- Spherical valve d20 up to d40
- Ball valve d50 up to d225
- d160 up to d225 are supplied with base plate and straps
- d1 = diameter of bore

* PE 80 SDR 11 5 bar Gas

d [mm]	Code	kg	L [mm]	L1 [mm]	H [mm]	H1 [mm]	d1 [mm]
20	193 103 031	0.750	254	75	127	78	23
25	193 103 032	0.750	254	75	127	78	23
32	193 103 033	0.750	254	75	127	78	23
40	193 103 034	0.750	254	75	127	78	23
50	193 103 035	1.500	325	91	231	164	47
63	193 103 036	1.700	325	91	231	164	47
75	193 103 037	1.900	325	91	231	164	47
90	193 103 038	2.000	325	91	231	164	47
110	193 103 039	4.000	405	112	290	205	64
125	193 103 040	4.300	405	112	290	205	64
160	193 103 042	9.600	508	160	363	263	92
180	193 103 043	10.000	540	123	364	247	92
200	193 103 044	10.800	540	123	364	247	92
*225	173 103 045	24.400	508	127	472	320	120

PF 2 51 308 004

Polyvalve Stop-Off Valve "Full Bore"

- PE 100 SDR 11 (ISO S5)
- 10 bar Gas / 16 bar Water
- Ball valve
- d1 = diameter of bore
- Free cross section according to SDR 11

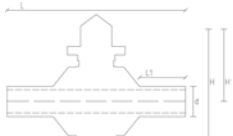

d [mm]	Code	kg	L [mm]	L1 [mm]	H [mm]	H1 [mm]	d1 [mm]
63	193 103 036	1.700	325	91	231	164	47
90	193 104 038	3.600	430	90	280	190	64
110	193 104 039	7.800	561	100	359	242	92
160	193 104 042	17.000	645	145	475	325	120

PF 2 51 308 005

Polyvalve operational key

- Made out of PVC
- Suitable for all dimensions



Length [mm]	Code	kg
200	173 103 082	1.000
500	173 103 083	0.692
1300	173 103 084	1.670

PF 2 51 308 003



PF 2 51 308 003

Polyvalve Accessory kit

- Extension spindle with protection pipe (500-900 mm) and cap

Article	Code	kg	
Kit	173 103 056	1.892	

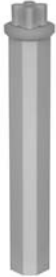

PF 2 51 308 003

Extension spindle

Length [mm]	Code	kg	
500	173 103 080	0.621	

Base plate with straps

Code	kg	
173 103 081	0.945	

PF 2 51 308 003



PF 2 51 308 003

Extension spindle, Telescopic



- Continuously adjustable and self-supporting
- Pullout- and dirt-safe
- Rod hot-dip galvanized
- PE-casing, PE-centering cap with gasket
- Polygon-bush from galvanized steel
- Clip-pin from stainless steel 1.4301
- PE-sleeve, fitted for all dimensions
- Torque max. 140 Nm

d-d [mm]	Pipe cover [m]	Code	kg	
32 - 225	0.75-1.10	173 103 075	1.700	
32 - 225	1.10-1.80	173 103 076	2.000	



Adapter for Polyvalve extension spindle



- Galvanized
- According to DIN 3223-C

L [mm]	Code	kg	
28	173 103 105	1.500	

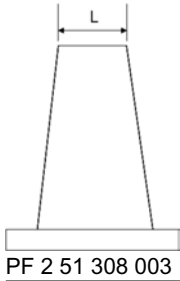

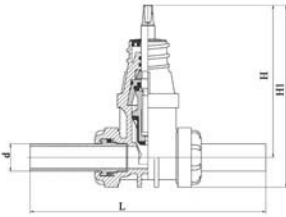

PF 2 51 786 099

POM Service Valve with PE Spigot ends



- PE 100 SDR 11 (ISO S5) Spigot ends
- 16 bar Water
- Gate valve is closed clockwise
- Spanner opening is 14 mm
- Resilient-seated Gate Valve
- Number of turns to fully open or close gate valve is 8 (d 32mm) and 11 (d 63mm)

d [mm]	Code	GP	kg	Bore d [mm]	L [mm]	H [mm]	H1 [mm]
32	193 301 008	8	1.050	25	277	177	216
63	193 301 011	4	2.050	40	206	206	261

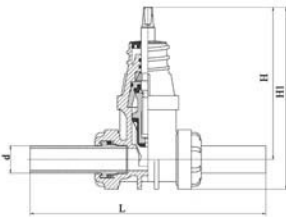

PF 2 51 786 099

POM Service Valve with PE Spigot ends (Kit)



- PE 100 SDR 11 (ISO S5) Spigot ends
- 16 bar Water
- Gate valve is closed clockwise
- Spanner opening is 14 mm
- Resilient-seated Gate Valve
- Number of turns to fully open or close gate valve is 8 (d 32mm) and 11 (d 63mm)
- Kit consists of 1x Service Valve (d32 or d63 mm) and 2x enclosed Service Line Fitting (ELGEF® Plus Coupler or Reducer)

d [mm]	d2 [mm]	Code	GP	kg	Bore d [mm]
32	20	193 301 016	4	1.192	25
32	25	193 301 017	4	1.170	25
32	32	193 301 018	4	1.170	25
63	40	193 301 019	2	2.402	40
63	50	193 301 020	2	2.410	40
63	63	193 301 021	2	2.438	40



POM Service Valve with male threads on both ends



- 16 bar Water
- Male Threads according to ISO 7-1
- Gate valve is closed clockwise
- Spanner opening is 14 mm
- Resilient-seated Gate Valve
- Number of turns to fully open or close gate valve is 8

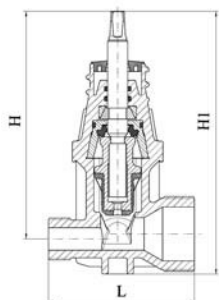

PF 2 51 786 099

R [inch]	Code	GP	kg	Bore d [mm]	L [mm]	H [mm]	H1 [mm]
1 - 1	193 301 028	12	0.800	25	110	182	201
1 - 2	193 301 031	12	0.850	25	116	182	210



POM Service Valve with male threads on both ends (Kit)



- 16 bar Water
- Male Threads according to ISO 7-1
- Gate valve is closed clockwise
- Spanner opening is 14 mm
- Resilient-seated Gate Valve
- Number of turns to fully open or close gate valve is 8

- Kit consists of 1x Service Valve DN 1" Male Thread R1"-R1" (Code 193 301 028) and 2x Poly16 Plus compression fittings with female thread Rp 1"

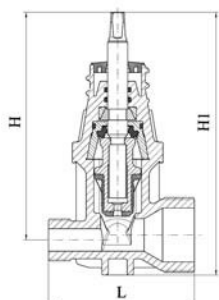

PF 2 51 786 099

R [inch]	d [mm]	Code	GP	kg	Bore d [mm]
1	25	193 301 037	6	0.966	25
1	32	193 301 038	6	1.034	25
1	40	193 301 039	6	1.224	25
1	50	193 301 040	6	1.364	25

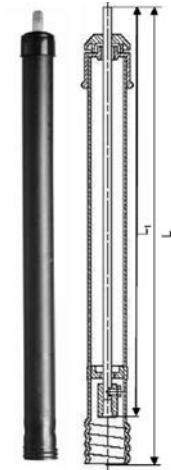

PF 2 51 786 002

Extension Spindle for POM Service Valve rigid



- Tight connection with the service valve through threaded end
- No additional split-pin needed
- PE outer protecting tube

Pipe cover [m]	Code	GP	kg	L [mm]	L1 [mm]
1.00	193 301 100	-	1.700	790	710
1.25	193 301 101	-	2.200	1040	960
1.50	193 301 102	-	2.700	1290	1210
2.00	193 301 105	-	3.700	1790	1710

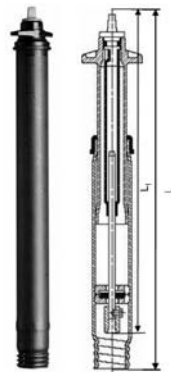

PF 2 51 786 002

Extension Spindle for POM Service Valve telescopic



- Tight connection with the service valve through threaded end
- No additional split-pin needed
- PE inner/outer protecting tube
- Perfect match to any ground level

Pipe cover [m]	Code	GP	kg	L [mm]	L1 [mm]
0,8-1,2	193 301 103	-	2.400	670 - 1040	590 - 960
1,3-1,8	193 301 104	-	3.500	960 - 1580	880 - 1500
1,8-2,3	193 301 106	-	4.910	1380 - 2080	1300 - 2000



**Polyethylene
Piping Systems PE 100**

Spigot Fittings for electrofusion
and butt fusion (long ends)

Spigot Fittings for
butt fusion (short ends)

Transition Fittings PE/steel

Flanges, seals

Spigot Fittings in PE 100

53 10 10

Elbow 90° Type L

- PE 100 SDR 11 (ISO S5)
- 10 bar Gas / 16 bar Water

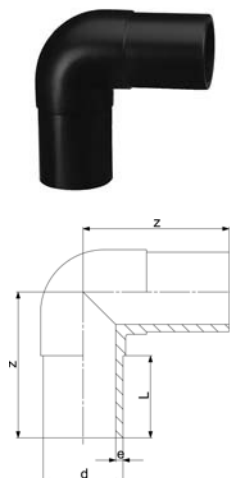

PF 2 51 301 001

d [mm]	Code	GP	kg	z [mm]	L [mm]	e [mm]
20	753 101 006	40	0.027	75	52	3.0
25	753 101 007	40	0.037	80	52	3.0
32	753 101 008	40	0.053	85	54	3.0
40	753 101 009	30	0.093	95	57	3.7
50	753 101 010	30	0.159	105	63	4.6
63	753 101 011	20	0.275	115	65	5.8
75	753 101 012	12	0.413	130	72	6.8
90	753 101 013	8	0.704	150	81	8.2
110	753 101 014	8	1.145	165	86	10.0
125	753 101 015	6	1.609	180	93	11.4
140	753 101 016	-	1.920	202	92	12.7
160	753 101 017	5	3.100	210	103	14.6
180	753 101 018	3	4.319	232	107	16.4
200	753 101 019	3	5.733	253	117	18.2
225	753 101 020	1	7.780	270	122	20.5
250	753 101 001	-	11.091	292	130	22.7
280	753 100 922	-	15.286	320	140	25.4
315	753 100 923	-	21.960	370	150	28.6

53 10 08

Elbow 90° Type L

- PE 100 SDR 17 (ISO S8)
- 5 bar Gas / 10 bar Water

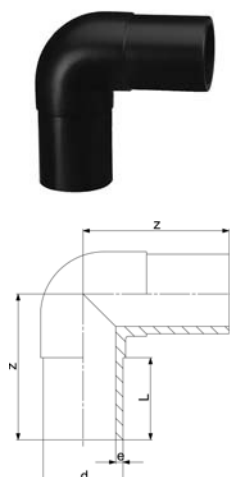

PF 2 51 301 001

d [mm]	Code	GP	kg	z [mm]	L [mm]	e [mm]
90	753 100 813	8	0.544	150	81	5,4
110	753 100 814	8	0.625	165	86	6,6
125	753 100 815	6	0.927	180	93	7,4
140	753 100 816	5	1.430	202	92	8,3
160	753 100 817	5	3.040	210	102	9,5
180	753 100 818	3	3.750	232	107	10,7
200	753 100 819	3	4.980	253	115	11,9
225	753 100 820	1	6.850	270	120	13,4
250	753 100 821	-	8.274	292	130	14,8
280	753 100 822	-	11.423	320	140	16,6
315	753 100 823	-	16.050	370	150	18,7

53 15 10

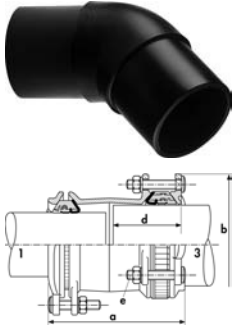

Elbow 45° Type L

- PE 100 SDR 11 (ISO S5)
- 10 bar Gas / 16 bar Water

d [mm]	Code	GP	kg	z [mm]	L [mm]	e [mm]
20	753 151 006	40	0.026	70	52	3,0
25	753 151 007	30	0.035	75	52	3,0
32	753 151 008	25	0.051	80	54	3,0
40	753 151 009	30	0.082	85	57	3,7
50	753 151 010	22	0.137	90	63	4,6
63	753 151 011	12	0.300	95	65	5,8
75	753 151 012	12	0.346	105	72	6,8
90	753 151 013	6	0.578	120	81	8,2
110	753 151 014	12	0.931	130	86	10,0
125	753 151 015	6	1.286	140	92	11,4
140	753 151 016	-	1.600	164	120	12,7
160	753 151 017	6	2.461	162	102	14,6
180	753 151 018	5	3.283	170	107	16,4
200	753 151 019	3	4.371	186	116	18,2
225	753 151 020	2	6.013	200	123	20,5
250	753 151 021	4	8.541	220	130	22,7
280	753 150 922	-	10.924	230	140	25,4
315	753 150 923	-	14.818	250	150	28,6

PF 2 51 301 001

53 15 08

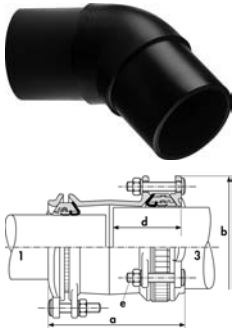

Elbow 45° Type L

- PE 100 SDR 17 (ISO S8)
- 5 bar Gas / 10 bar Water

d [mm]	Code	GP	kg	z [mm]	L [mm]	e [mm]
90	753 150 813	6	0.450	120	81	5,4
110	753 150 814	12	0.900	130	86	6,6
125	753 150 815	6	1.250	140	92	7,4
140	753 150 816	-	1.100	164	120	8,3
160	753 150 817	6	2.390	162	102	9,5
180	753 150 818	5	3.060	170	107	10,7
200	753 150 819	3	4.100	186	116	11,9
225	753 150 820	2	5.610	205	123	13,4
250	753 150 821	-	6.227	220	130	14,8
280	753 150 822	-	7.819	230	140	16,6
315	753 150 823	-	10.596	250	150	18,7

PF 2 51 301 001

53 12 09

Elbow 30° LS

- PE 100 SDR 11 (ISO S5)
- 10 bar Gas / 16 bar Water
- Welded design

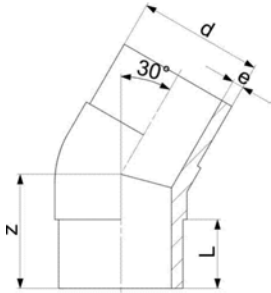

PF 2 51 301 005

d [mm]	Code	GP	kg	z [mm]	L [mm]	e [mm]
32	753 120 908	20	0.050	70	54	3,0
40	753 120 909	40	0.530	80	57	3,7
50	753 120 910	6	0.530	80	63	4,6
63	753 120 911	8	0.207	80	65	5,8
75	753 120 912	10	0.530	90	72	6,8
90	753 120 913	-	0.540	100	81	8,2
110	753 120 914	4	0.840	105	86	10,0
125	753 120 915	6	1.240	115	92	11,4
140	753 120 916	-	1.760	135	92	12,7
160	753 120 917	6	2.050	130	102	14,6
180	753 120 918	5	2.907	140	107	16,4
200	753 120 919	2	8.600	150	116	18,2
225	753 120 920	2	5.360	165	123	20,5
250	753 120 921	2	7.300	190	130	22,7
280	753 120 922	1	10.600	200	139	25,4
315	753 120 923	1	10.100	200	150	28,6

53 12 08

Elbow 30° LS

- PE 100 SDR 17 (ISO S8)
- 5 bar Gas / 10 bar Water
- Welded design

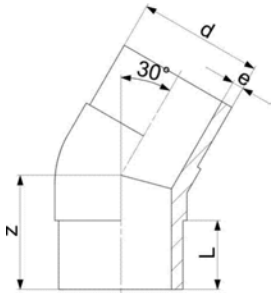

PF 2 51 301 005

d [mm]	Code	GP	kg	z [mm]	L [mm]	e [mm]
90	753 120 813	-	0.430	110	81	5,4
110	753 120 814	4	0.620	115	86	6,6
125	753 120 815	2	1.070	125	92	7,4
140	753 120 816	-	1.490	150	92	8,3
160	753 120 817	6	1.600	140	102	9,5
180	753 120 818	2	2.040	150	107	10,7
200	753 120 819	2	2.780	160	116	11,9
225	753 120 820	2	3.880	180	123	13,4
250	753 120 821	2	5.830	200	130	14,8
280	753 120 822	-	8.100	200	139	16,6
315	753 120 823	1	11.200	220	150	18,7

Elbow 15° LS

- PE 100 SDR 11 (ISO S5)
- 10 bar Gas / 16 bar Water
- Welded design

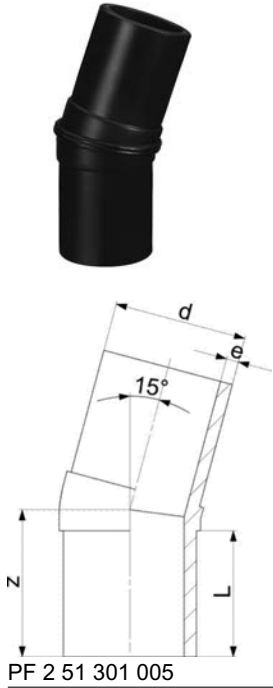

d [mm]	Code	GP	kg	z [mm]	L [mm]	e [mm]
32	753 141 008	-	0.051	70	54	3.0
40	753 141 009	15	0.082	80	57	3.7
50	753 141 010	20	0.137	80	63	4.6
63	753 141 011	8	0.200	80	65	5.8
75	753 141 012	2	0.250	90	72	6.8
90	753 141 013	5	0.487	100	81	8.2
110	753 141 014	4	0.785	105	86	10.0
125	753 141 015	6	1.070	115	92	11.4
140	753 141 016	6	1.600	135	92	12.7
160	753 141 017	6	2.050	130	102	14.6
180	753 141 018	2	2.669	140	107	16.4
200	753 141 019	3	3.440	150	116	18.2
225	753 141 020	2	4.900	165	123	20.5
250	753 141 021	1	8.300	190	130	22.7
280	753 141 022	1	9.500	200	139	25.4
315	753 141 023	1	13.100	200	150	28.6

Elbow 15° LS

- PE 100 SDR 17 (ISO S8)
- 5 bar Gas / 10 bar Water
- Welded design

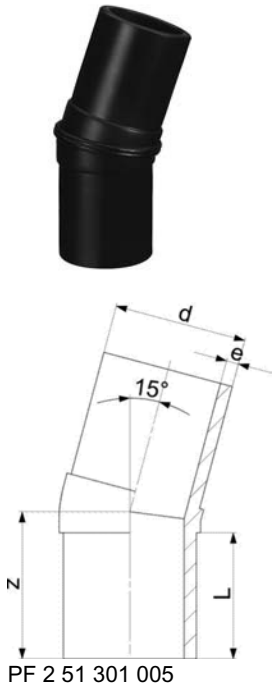

d [mm]	Code	GP	kg	z [mm]	L [mm]	e [mm]
90	753 140 813	4	0.370	100	81	5.4
110	753 140 814	3	0.620	105	86	6.6
125	753 140 815	2	0.990	115	92	7.4
140	753 140 816	2	0.370	135	92	8.3
160	753 140 817	5	1.600	130	102	9.5
180	753 140 818	-	2.040	140	107	10.7
200	753 140 819	2	2.780	150	116	11.9
225	753 140 820	2	4.820	165	123	13.4
250	753 140 821	2	5.830	190	130	14.8
280	753 140 822	2	8.100	195	139	16.6
315	753 140 823	1	11.200	200	150	18.7

53 00 09

Bend 90° LS

- PE 100 SDR 11 (ISO S5)
- 10 bar Gas / 16 bar Water

* made out of seamless pipe

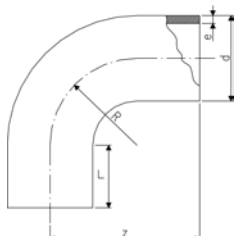

d [mm]	Code	GP	kg	z [mm]	L [mm]	R [mm]	e [mm]
20	753 001 006	-	0.020	63	41	20	1,9
25	753 001 007	-	0.030	68	41	25	2,3
32	753 001 008	-	0.050	78	46	32	2,9
40	753 001 009	-	0.090	91	49	40	3,7
50	753 001 010	-	0.160	107	55	50	4,6
63	753 001 011	-	0.290	130	63	63	5,8
75	753 001 012	32	0.300	152	70	75	6,8
90	753 001 013	-	0.530	168	79	90	8,2
110	753 001 014	12	0.890	193	82	110	10,0
125	753 001 015	-	1.290	216	87	125	11,4
140	753 001 016	-	2.230	232	92	140	12,7
160	753 001 017	8	2.460	258	98	160	14,6
180	753 001 018	-	5.000	290	105	180	16,4
200	753 001 019	-	4.480	317	112	200	18,2
225	753 001 020	-	9.770	350	120	225	20,5
250	753 001 021	-	9.230	375	130	250	22,7
280	753 001 022	-	17.410	430	150	280	25,4
315	753 001 023	-	23.950	470	150	315	28,6
*355	753 001 024	-	53.300	900	250	533	32,3
*400	753 001 025	-	71.900	980	250	600	36,4
*450	753 001 026	-	97.300	1070	250	675	40,9
*500	753 001 027	-	134.000	1200	280	750	45,5
*560	753 001 028	-	179.300	1290	280	840	50,9
*630	753 001 029	-	243.200	1400	280	945	57,3

PF 2 51 301 005

53 00 08

Bend 90° Type L

- PE 100 SDR 17 (ISO S8)
- 5 bar Gas / 10 bar Water

* made out of seamless pipe

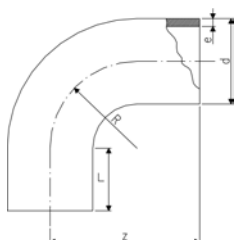

d [mm]	Code	GP	kg	z [mm]	L [mm]	R [mm]	e [mm]
90	753 000 813	-	0.600	168	79	90	5,4
110	753 000 814	-	1.000	193	82	110	6,6
125	753 000 815	-	1.300	216	87	125	7,4
140	753 000 816	-	2.500	232	92	140	8,3
160	753 000 817	-	2.500	258	98	160	9,5
180	753 000 818	-	4.000	290	105	180	10,7
200	753 000 819	-	6.500	317	112	200	11,9
225	753 000 820	-	8.500	350	120	225	13,4
250	753 000 821	-	8.500	375	130	250	14,8
280	753 000 822	-	15.000	430	150	280	16,6
315	753 000 823	-	24.000	470	150	315	18,7
*355	753 000 824	-	36.700	900	250	533	21,1
*400	753 000 825	-	49.700	980	250	600	23,7
*450	753 000 826	-	66.600	1070	250	675	26,7
*500	753 000 827	-	87.400	1200	280	750	29,7
*560	753 000 828	-	116.000	1290	280	840	33,2
*630	753 000 829	-	159.600	1400	280	945	37,4

PF 2 51 301 005

53 07 10

Bend 60° LS

- PE 100 SDR 11 (ISO S5)
- 10 bar Gas / 16 bar Water
- made out of seamless pipe

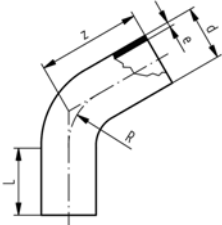

d [mm]	Code	GP	kg	z [mm]	L [mm]	R [mm]	e [mm]
32	753 071 008	-	0.070	128	80	48	2,9
40	753 071 009	-	0.120	135	80	60	3,7
50	753 071 010	-	0.240	158	100	75	4,6
63	753 071 011	-	0.420	173	100	95	5,8
75	753 071 012	-	0.600	182	100	113	6,8
90	753 071 013	-	0.900	193	100	135	8,2
110	753 071 014	-	1.780	270	150	165	10,0
125	753 071 015	-	2.500	283	150	188	11,4
140	753 071 016	-	2.700	296	150	210	12,7
160	753 071 017	-	4.500	313	150	240	14,6
180	753 071 018	-	4.900	330	150	270	16,4
200	753 071 019	-	6.400	348	150	300	18,2
225	753 071 020	-	8.600	370	150	338	20,5
250	753 071 021	-	14.500	500	250	375	22,7
280	753 071 022	-	19.100	530	250	420	25,4
315	753 071 023	-	25.600	612	250	473	28,6
355	753 071 024	-	41.700	690	300	533	32,3
400	753 071 025	-	55.800	730	300	600	36,4
450	753 071 026	-	76.000	780	300	675	40,9
500	753 071 027	-	104.600	880	350	750	45,5
560	753 071 028	-	139.500	930	350	840	50,9
630	753 071 029	-	188.500	1000	350	945	57,3

PF 2 51 301 009

53 07 08

Bend 60° LS

- PE 100 SDR 17 (ISO S8)
- 5 bar Gas / 10 bar Water
- made out of seamless pipe

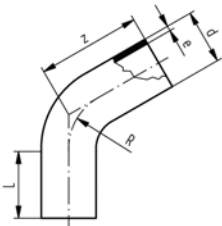

d [mm]	Code	GP	kg	z [mm]	L [mm]	R [mm]	e [mm]
90	753 070 813	-	0.600	193	100	135	5,4
110	753 070 814	-	1.280	270	150	165	6,6
125	753 070 815	-	1.300	283	150	187	7,4
140	753 070 816	-	1.800	296	150	210	8,3
160	753 070 817	-	3.160	313	150	240	9,5
180	753 070 818	-	3.190	330	150	270	10,7
200	753 070 819	-	4.200	348	150	300	11,9
225	753 070 820	-	5.600	370	150	337	13,4
250	753 070 821	-	9.250	500	250	375	14,8
280	753 070 822	-	15.000	530	250	420	16,6
315	753 070 823	-	19.500	612	250	472	18,7
355	753 070 824	-	30.100	690	300	532	21,1
400	753 070 825	-	38.200	730	300	600	23,7
450	753 070 826	-	53.700	780	300	675	26,7
500	753 070 827	-	73.900	880	350	750	29,7
560	753 070 828	-	98.200	930	350	840	33,2
630	753 070 829	-	132.300	1000	350	945	37,4

PF 2 51 301 009

53 05 10

Bend 45° LS

- PE 100 SDR 11 (ISO S5)
- 10 bar Gas / 16 bar Water
- made out of seamless pipe

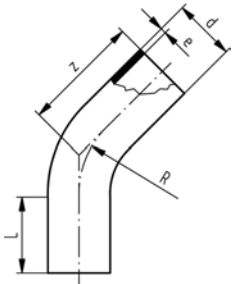

PF 2 51 301 009

d [mm]	Code	GP	kg	z [mm]	L [mm]	R [mm]	e [mm]
32	753 051 008	-	0.077	120	80	48	2,9
40	753 051 009	-	0.120	120	80	60	3,7
50	753 051 010	-	0.240	149	100	75	4,6
63	753 051 011	-	0.360	161	100	95	5,8
75	753 051 012	-	0.560	168	100	113	6,8
90	753 051 013	-	0.760	177	100	135	8,2
110	753 051 014	-	1.700	243	150	165	10,0
125	753 051 015	-	2.300	253	150	188	11,4
140	753 051 016	-	2.800	262	150	210	12,7
160	753 051 017	-	3.800	274	160	240	14,6
180	753 051 018	-	5.140	287	150	270	16,4
200	753 051 019	-	5.600	299	150	300	18,2
225	753 051 020	-	7.400	315	150	338	20,5
250	753 051 021	-	13.000	440	250	375	22,7
280	753 051 022	-	15.000	460	250	420	25,4
315	753 051 023	-	24.930	535	250	473	28,6
355	753 051 024	-	39.500	620	300	533	32,3
400	753 051 025	-	48.500	650	300	600	36,4
450	753 051 026	-	69.800	680	300	675	40,9
500	753 051 027	-	96.300	760	350	750	45,5
560	753 051 028	-	129.800	800	350	840	50,9
630	753 051 029	-	174.000	870	350	945	57,3

53 05 08

Bend 45° LS

- PE 100 SDR 17 (ISO S8)
- 5 bar Gas / 10 bar Water
- made out of seamless pipe

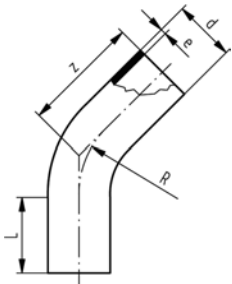

PF 2 51 301 009

d [mm]	Code	GP	kg	z [mm]	L [mm]	R [mm]	e [mm]
90	753 050 813	-	0.600	177	100	135	5,4
110	753 050 814	-	1.100	243	150	165	6,6
125	753 050 815	-	1.200	253	150	188	7,4
140	753 050 816	-	1.720	262	150	210	8,3
160	753 050 817	-	2.200	274	150	240	9,5
180	753 050 818	-	3.000	287	150	270	10,7
200	753 050 819	-	3.700	299	150	300	11,9
225	753 050 820	-	5.000	315	150	338	13,4
250	753 050 821	-	10.000	440	250	375	14,8
280	753 050 822	-	15.000	460	250	420	16,6
315	753 050 823	-	17.800	535	250	473	18,7
355	753 050 824	-	25.600	620	300	533	21,1
400	753 050 825	-	36.600	650	300	600	23,7
450	753 050 826	-	45.300	680	300	675	26,7
500	753 050 827	-	62.400	760	350	750	29,7
560	753 050 828	-	81.900	800	350	840	33,2
630	753 050 829	-	62.400	870	350	945	37,4

53 06 10

Bend 30° LS

- PE 100 SDR 11 (ISO S5)
- 10 bar Gas / 16 bar Water
- made out of seamless pipe

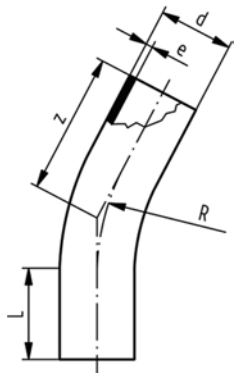

PF 2 51 301 009

d [mm]	Code	GP	kg	z [mm]	L [mm]	R [mm]	e [mm]
32	753 061 008	-	0.077	113	80	48	2,9
40	753 061 009	-	0.120	116	80	60	3,7
50	753 061 010	-	0.200	140	100	75	4,6
63	753 061 011	-	0.400	150	100	95	5,8
75	753 061 012	-	0.520	155	100	113	6,8
90	753 061 013	-	0.760	160	100	135	8,2
110	753 061 014	-	1.500	219	150	165	10,0
125	753 061 015	-	2.000	225	150	188	11,4
140	753 061 016	-	2.200	231	150	210	12,7
160	753 061 017	-	3.300	239	150	240	14,6
180	753 061 018	-	3.700	247	150	270	16,4
200	753 061 019	-	4.750	255	150	300	18,2
225	753 061 020	-	6.300	266	150	338	20,5
250	753 061 021	-	13.100	385	250	375	22,7
280	753 061 022	-	16.300	400	250	420	25,4
315	753 061 023	-	21.850	460	250	473	28,6
355	753 061 024	-	34.900	540	300	533	32,3
400	753 061 025	-	45.900	560	300	600	36,4
450	753 061 026	-	60.200	580	300	675	40,9
500	753 061 027	-	83.300	630	350	750	45,5
560	753 061 028	-	108.600	680	350	840	50,9
630	753 061 029	-	148.300	730	350	945	57,3

53 06 08

Bend 30° LS

- PE 100 SDR 17 (ISO S8)
- 5 bar Gas / 10 bar Water
- made out of seamless pipe

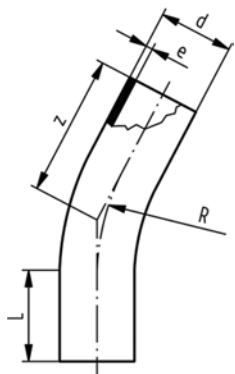

PF 2 51 301 009

d [mm]	Code	GP	kg	z [mm]	L [mm]	R [mm]	e [mm]
90	753 060 813	-	0.500	160	100	135	5,4
110	753 060 814	-	1.060	219	150	165	6,6
125	753 060 815	-	1.100	225	150	188	7,4
140	753 060 816	-	1.720	231	150	210	8,3
160	753 060 817	-	1.900	239	150	240	9,5
180	753 060 818	-	2.500	247	150	270	10,7
200	753 060 819	-	3.200	255	150	300	11,9
225	753 060 820	-	7.540	266	150	338	13,4
250	753 060 821	-	11.600	385	250	375	14,8
280	753 060 822	-	12.800	400	250	420	16,6
315	753 060 823	-	25.000	460	250	473	18,7
355	753 060 824	-	22.700	540	300	533	21,1
400	753 060 825	-	29.800	560	300	600	23,7
450	753 060 826	-	39.100	580	300	675	26,7
500	753 060 827	-	54.000	650	350	750	29,7
560	753 060 828	-	70.300	680	350	840	33,2
630	753 060 829	-	95.800	730	350	945	37,4



Bend 22° LS

- PE 100 SDR 11 (ISO S5)
- 10 bar Gas / 16 bar Water
- made out of seamless pipe

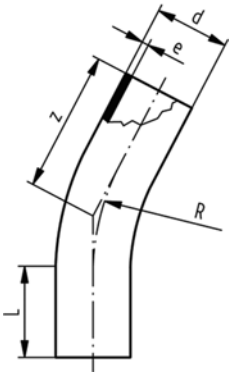

PF 2 51 301 009

d [mm]	Code	GP	kg	z [mm]	L [mm]	R [mm]	e [mm]
32	753 081 008	-	0.077	113	80	48	2,9
40	753 081 009	-	0.120	116	80	60	3,7
50	753 081 010	-	0.200	140	100	75	4,6
63	753 081 011	-	0.400	150	100	95	5,8
75	753 081 012	-	0.520	155	100	113	6,8
90	753 081 013	-	0.760	160	100	135	8,2
110	753 081 014	-	1.500	219	150	165	10,0
125	753 081 015	-	2.000	225	150	188	11,4
140	753 081 016	-	2.200	231	150	210	12,7
160	753 081 017	-	3.300	239	150	240	14,6
180	753 081 018	-	3.700	247	150	270	16,4
200	753 081 019	-	4.750	255	150	300	18,2
225	753 081 020	-	6.300	266	150	338	20,5
250	753 081 021	-	13.100	385	250	375	22,7
280	753 081 022	-	16.300	400	250	420	25,4
315	753 081 023	-	21.845	460	250	473	28,6
355	753 081 024	-	34.900	540	300	533	32,3
400	753 081 025	-	45.900	560	300	600	36,4
450	753 081 026	-	60.200	580	300	675	40,9
500	753 081 027	-	83.300	650	350	750	45,5
560	753 081 028	-	108.600	680	350	840	50,9
630	753 081 029	-	148.300	730	350	945	57,3



Bend 22° LS

- PE 100 SDR 17 (ISO S8)
- 5 bar Gas / 10 bar Water
- made out of seamless pipe

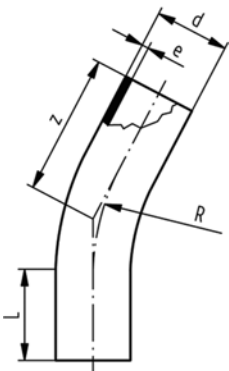

PF 2 51 301 009

d [mm]	Code	GP	kg	z [mm]	L [mm]	R [mm]	e [mm]
90	753 080 813	-	0.500	160	100	135	5,4
110	753 080 814	-	1.060	219	150	165	6,6
125	753 080 815	-	1.100	225	150	188	7,4
140	753 080 816	-	1.720	231	150	210	8,3
160	753 080 817	-	1.900	239	150	240	9,5
180	753 080 818	-	2.500	247	150	270	10,7
200	753 080 819	-	3.200	255	150	300	11,9
225	753 080 820	-	7.540	266	150	338	13,4
250	753 080 821	-	11.600	385	250	375	14,8
280	753 080 822	-	12.800	400	250	420	16,6
315	753 080 823	-	25.000	460	250	473	18,7
355	753 080 824	-	22.700	540	300	533	21,1
400	753 080 825	-	29.800	560	300	600	23,7
450	753 080 826	-	39.100	580	300	675	26,7
500	753 080 827	-	54.000	650	350	750	29,7
560	753 080 828	-	70.300	680	350	840	33,2
630	753 080 829	-	95.800	730	350	945	37,4



Bend 11° LS

- PE 100 SDR 11 (ISO S5)
- 10 bar Gas / 16 bar Water
- made out of seamless pipe

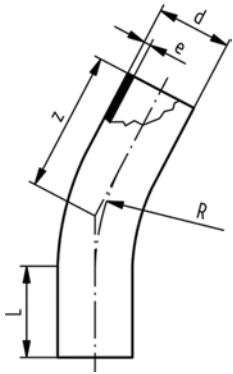

PF 2 51 301 009

d [mm]	Code	GP	kg	z [mm]	L [mm]	R [mm]	e [mm]
32	753 091 008	-	0.077	113	80	48	2.9
40	753 091 009	-	0.120	116	80	60	3.7
50	753 091 010	-	0.200	140	100	75	4.6
63	753 091 011	-	0.400	150	100	95	5.8
75	753 091 012	-	0.520	155	100	113	6.8
90	753 091 013	-	0.760	160	100	135	8.2
110	753 091 014	-	1.500	219	150	165	10.0
125	753 091 015	-	2.000	225	150	188	11.4
140	753 091 016	-	2.200	231	150	210	12.7
160	753 091 017	-	3.300	239	150	240	14.6
180	753 091 018	-	3.700	247	150	270	16.4
200	753 091 019	-	4.750	255	150	300	18.2
225	753 091 020	-	6.300	266	150	338	20.5
250	753 091 021	-	13.100	385	250	375	22.7
280	753 091 022	-	16.300	400	250	420	25.4
315	753 091 023	-	21.845	460	250	473	28.6
355	753 091 024	-	34.900	540	300	533	32.3
400	753 091 025	-	45.900	560	300	600	36.4
450	753 091 026	-	60.200	580	300	675	40.9
500	753 091 027	-	83.300	650	350	750	45.5
560	753 091 028	-	108.600	680	350	840	50.9
630	753 091 029	-	148.300	730	350	945	57.3



Bend 11° LS

- PE 100 SDR 17 (ISO S8)
- 5 bar Gas / 10 bar Water
- made out of seamless pipe

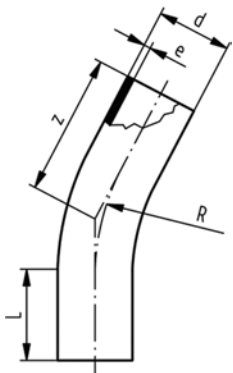

PF 2 51 301 009

d [mm]	Code	GP	kg	z [mm]	L [mm]	R [mm]	e [mm]
90	753 090 813	-	0.500	160	100	135	5.4
110	753 090 814	-	1.060	219	150	165	6.6
125	753 090 815	-	1.100	225	150	188	7.4
140	753 090 816	-	1.720	231	150	210	8.3
160	753 090 817	-	1.900	239	150	240	9.5
180	753 090 818	-	2.500	247	150	270	10.7
200	753 090 819	-	3.200	255	150	300	11.9
225	753 090 820	-	7.540	266	150	338	13.4
250	753 090 821	-	11.600	385	250	375	14.8
280	753 090 822	-	12.800	400	250	420	16.6
315	753 090 823	-	25.000	460	250	473	18.7
355	753 090 824	-	22.700	540	300	533	21.1
400	753 090 825	-	29.800	560	300	600	23.7
450	753 090 826	-	39.100	580	300	675	26.7
500	753 090 827	-	54.000	650	350	750	29.7
560	753 090 828	-	70.300	680	350	840	33.2
630	753 090 829	-	95.800	730	350	945	37.4

53 20 10

Tee 90°, equal Type L

- PE 100 SDR 11 (ISO S5)
- 10 bar Gas / 16 bar Water

- * With welded pipes
- * Segment welded and reinforced
- * No pressure reduction factor

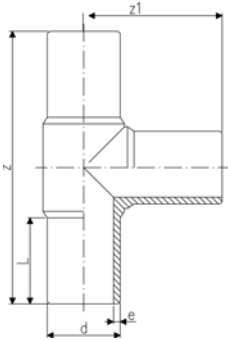

d [mm]	Code	GP	kg	z [mm]	z1 [mm]	L [mm]	e [mm]
20	753 201 006	30	0.038	150	75	52	3,0
25	753 201 007	25	0.054	160	80	52	3,0
32	753 201 008	20	0.074	170	85	54	3,0
40	753 201 009	20	0.127	190	95	57	3,7
50	753 201 010	20	0.217	210	105	63	4,6
63	753 201 011	14	0.375	230	115	65	5,8
75	753 201 012	16	0.616	264	132	72	6,8
90	753 201 013	7	1.031	300	150	81	8,2
110	753 201 014	5	1.660	330	165	86	10,0
125	753 201 015	4	2.215	366	183	92	11,4
140	753 201 016	-	3.200	396	196	92	12,7
160	753 201 017	4	4.320	420	210	102	14,6
180	753 201 018	3	5.980	460	230	107	16,4
200	753 201 019	2	7.760	500	250	117	18,2
225	753 201 020	-	10.485	540	270	122	20,5
250	753 201 001	-	14.708	575	288	130	22,7
280	753 200 902	-	18.670	615	308	139	25,4
315	753 200 903	-	26.150	695	346	150	28,6
355	753 200 904	-	39.800	818	410	165	32,3
400	753 200 905	-	42.495	910	455	180	36,4
450	753 200 906	-	77.300	970	485	195	40,9
500	753 200 907	-	101.000	1060	530	215	45,5
*560	753 200 908	-	153.300	1510			50,9
*630	753 200 909	-	205.500				57,3

PF 2 51 301 001

53 20 08

Tee 90°, equal Type L

- PE 100 SDR 17 (ISO S8)
- 5 bar Gas / 10 bar Water

- * Segment welded and reinforced
- * With welded pipes
- * No pressure reduction factor

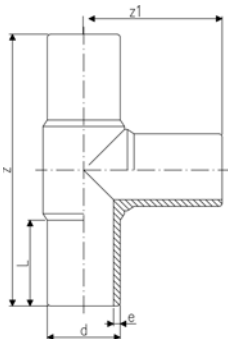

d [mm]	Code	GP	kg	z [mm]	z1 [mm]	L [mm]	e [mm]
90	753 200 813	7	0.780	300	150	80	5,4
110	753 200 814	5	1.440	330	165	86	6,6
125	753 200 815	4	1.646	366	183	92	7,4
140	753 200 816	-	2.120	396	196	92	8,3
160	753 200 817	4	3.970	428	214	104	9,5
180	753 200 818	3	5.450	460	230	105	10,7
200	753 200 819	2	5.910	500	250	115	11,9
225	753 200 820	1	8.240	540	270	122	13,4
250	753 200 821	-	10.793	575	288	130	14,8
280	753 200 802	1	13.810	615	308	139	16,6
315	753 200 803	-	18.155	695	346	150	18,7
355	753 200 804	-	25.850	818	410	165	21,1
400	753 200 805	-	35.015	910	455	180	23,7
450	753 200 806	-	56.000	970	485	195	26,7
500	753 200 807	-	71.000	1060	530	215	29,7
*560	753 200 808	-	99.200	1510	755	230	33,2
*630	753 200 809	-	132.700	1630	815	250	37,4

PF 2 51 301 001

Tee 90°, reduced LS moulded

- PE 100 SDR 11 (ISO S5)
- 10 bar Gas / 16 bar Water

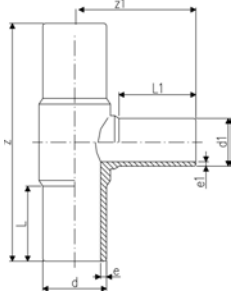

d	d1	Code	GP	kg	z	z1	L	L1	e	e1
[mm]	[mm]				[mm]	[mm]	[mm]	[mm]	[mm]	[mm]
63	50	753 201 044	10	0.300	215	103	63	56	5.8	4.6
75	32	753 201 045	10	0.490	256	108	70	46	6.8	2.9
75	50	753 201 046	10	0.530	253	113	70	56	6.8	4.6
75	63	753 201 047	10	0.560	255	117	70	63	6.8	5.8
90	50	753 201 027	-	0.820	280	117	79	55	8.2	4.6
90	63	753 201 029	-	0.775	280	123	79	63	8.2	5.8
90	75	753 201 030	3	0.793	272	138	73	68	8.2	6.8
110	63	753 201 028	-	1.267	320	147	87	63	10.0	5.8
110	75	753 201 031	2	1.244	309	151	82	70	10.0	6.8
110	90	753 201 032	-	1.275	320	158	86	79	10.0	8.2
125	90	753 201 048	3	2.389	340	170	112	92	11.4	8.2
125	110	753 201 033	3	1.860	341	170	90	83	11.4	10.0
160	63	753 201 034	-	2.680	343	176	98	65	14.6	5.8
160	75	753 201 035	3	2.726	343	180	98	74	14.6	6.8
160	90	753 201 036	-	2.775	412	188	101	79	14.6	8.2
160	110	753 201 037	-	3.300	412	195	101	82	14.6	10.0
180	90	753 201 049	1	4.100	418	200	136	97	16.4	8.2
180	110	753 201 050	-	4.379	430	206	130	101	16.4	10.0
180	160	753 201 038	1	4.379	411	205	105	94	16.4	14.6
200	63	753 201 073	-	7.300	500	190	122	63	18.2	5.8
200	90	753 201 074	-	9.730	500	207	122	79	18.2	8.2
200	110	753 201 075	-	9.730	500	215	122	82	18.2	10.0
200	160	753 201 076	-	9.730	500	234	122	98	18.2	14.6
225	75	753 201 039	1	6.500	555	215	120	70	20.5	6.8
225	90	753 201 040	3	6.633	558	226	120	80	20.5	8.2
225	110	753 201 041	3	6.600	558	235	120	82	20.5	10.0
225	160	753 201 042	3	8.095	560	253	120	98	20.5	14.6
225	180	753 201 043	-	9.375	560	280	120	105	20.5	16.4
250	110	753 201 078	-	9.730	575	242	130	82	22.7	10.0
250	160	753 201 079	-	9.730	575	261	127	98	22.7	14.6
315	110	753 201 051	-	15.300	695	277	150	82	28.6	10.0
315	160	753 201 052	-	16.600	695	296	150	102	28.6	14.6
315	225	753 201 053	-	20.500	650	335	170	145	28.6	20.5
315	250	753 201 054	-	22.000	695	325	150	130	28.6	22.7

PF 2 51 301 004

53 20 08

Tee 90°, reduced LS moulded

- PE 100 SDR 17 (ISO S8)
- 5 bar Gas / 10 bar Water

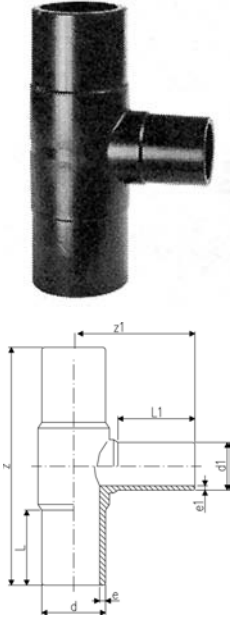

d [mm]	d1 [mm]	Code	GP	kg	z [mm]	z1 [mm]	L [mm]	L1 [mm]	e [mm]	e1 [mm]	e2 [mm]
90	50	753 201 827	-	0.630	275	117	79	55	5.4	3,0	3.0
90	63	753 200 829	-	0.560	275	123	79	63	5.4	3,8	3.8
90	75	753 200 830	-	0.593	272	139	74	71	5.4	4,5	4.5
110	63	753 200 828	-	0.900	318	147	82	63	6.6	3,8	3.8
110	75	753 200 831	2	0.882	315	152	84	70	6.6	4,5	4.5
110	90	753 200 832	-	0.941	318	158	82	79	6.6	5,4	5.4
125	110	753 200 833	1	1.282	334	168	84	83	7.4	6,6	6.6
160	63	753 200 834	-	1.950	330	130	86	63	9.5	3,8	3.8
160	75	753 200 835	-	1.960	343	180	98	74	9.5	4,5	4.5
160	90	753 200 836	-	1.972	410	188	98	79	9.5	5,4	5.4
160	110	753 200 837	-	2.414	410	195	98	82	9.5	6,6	6.6
180	90	753 200 844	1	3.218	422	204	134	97	10.7	5,4	5.4
180	160	753 200 838	1	5.890	411	205	105	94	10.7	9,5	9.5
200	63	753 201 873	-	6.800	500	190	122	63	11.9	3,8	3.8
200	90	753 201 874	-	6.900	500	207	122	79	11.9	5,4	5.4
200	110	753 201 875	-	7.200	500	215	122	82	11.9	6,6	6.6
200	160	753 201 876	-	7.400	500	234	122	98	11.9	9,5	9.5
225	75	753 200 839	-	4.600	555	277	120	70	13.4	4,5	4.5
225	90	753 200 840	-	4.732	555	226	127	80	13.4	5,4	5.4
225	110	753 200 841	-	4.700	555	235	127	82	13.4	6,6	6.6
225	160	753 200 842	-	5.922	555	253	127	98	13.4	9,5	9.5
225	180	753 200 843	-	7.211	550	280	120	105	13.4	10,7	10.7
250	110	753 201 878	-	9.400	575	242	130	82	14.8	6,6	6.6
250	160	753 201 879	-	9.800	575	261	130	98	14.8	9,5	9.5
315	110	753 200 851	1	10.800	695	277	150	82	18.7	6,6	6.6
315	160	753 200 852	-	12.200	695	296	150	102	18.7	9,5	9.5
315	225	753 200 853	-	14.500	650	335	170	145	18.7	13,4	13.4
315	250	753 200 854	-	15.500	695	325	150	130	18.7	14,8	14.8

PF 2 51 301 004

Tee 90°, reduced LS with welded reducer

- PE 100 SDR 11 (ISO S5)
- 10 bar Gas / 16 bar Water
- With welded reducer

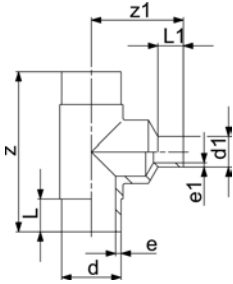

d [mm]	d1 [mm]	Code	GP	kg	z [mm]	z1 [mm]	L [mm]	L1 [mm]	e [mm]	e1 [mm]
25	20	753 201 002	-	0.053	160		52	52	3,0	3,0
32	20	753 201 003	2	0.094	170	105	54	52	3,0	3,0
32	25	753 201 004	-	0.098	170	110	54	52	3,0	3,0
40	20	753 201 005	2	0.155	190	120	57	52	3,7	3,0
40	25	753 201 069	-	0.160	190	120	57	52	3,7	3,0
40	32	753 201 070	6	0.160	190	120	57	52	3,7	3,0
50	20	753 201 072	20	0.252	210	140	63	52	4,6	3,0
50	25	753 201 077	10	0.260	210	130	63	52	4,6	3,0
50	32	753 201 080	20	0.267	210	130	63	53	4,6	3,0
50	40	753 201 081	4	0.276	210	130	63	57	4,6	3,7
63	32	753 201 082	6	0.460	230	140	65	53	5,8	3,0
63	40	753 201 116	12	0.480	230	145	65	57	5,8	3,7
75	40	753 201 084	4	0.755	264	180	72	57	6,8	3,7
125	63	753 201 085	8	2.850	366	225	92	61	11,4	5,8
125	75	753 201 086	-	2.880	366	235	92	72	11,4	6,8
140	75	753 201 087	4	4.050	396	230	92	70	12,7	6,8
140	90	753 201 089	4	4.095	396	235	92	79	12,7	8,2
140	110	753 201 090	-	4.120	396	240	92	82	12,7	10,0
140	125	753 201 091	2	4.170	396	240	92	90	12,7	11,4
160	125	753 201 092	4	5.715	420	265	102	92	14,6	11,4
160	140	753 201 093	4	5.895	420	270	102	96	14,6	12,7
180	125	753 201 094	2	8.930	460	285	107	92	16,4	11,4
180	140	753 201 095	-	9.070	460	295	107	110	16,4	12,7
200	125	753 201 096	1	10.460	500	295	117	92	18,2	11,4
200	140	753 201 097	1	10.570	500	310	117	110	18,2	12,7
200	180	753 201 098	1	9.500	500	310	117	110	18,2	16,4
225	125	753 201 099	-	14.470	540	320	122	92	20,5	11,4
225	140	753 201 100	1	14.574	540	335	122	110	20,5	12,7
225	200	753 201 101	-	14.925	540	340	122	117	20,5	18,2
250	180	753 201 102	-	18.890	576	350	130	105	22,7	16,4
250	200	753 201 103	-	19.220	576	360	130	112	22,7	18,2
250	225	753 201 104	-	19.690	576	390	130	120	22,7	20,5
280	200	753 201 105	-	24.520	616	410	139	112	25,4	18,2
280	225	753 201 106	-	24.755	616	420	139	120	25,4	20,5
280	250	753 201 107	-	25.210	616	420	139	130	25,4	22,7
315	200	753 201 108	-	33.950	690	470	150	134	28,6	18,2
315	280	753 201 109	-	34.950	690	480	150	139	28,6	25,4
355	250	753 201 110	-	48.900	818	530	165	130	32,3	22,7
355	280	753 201 111	-	49.300	818	480	165	139	32,3	25,4
355	315	753 201 112	-	49.690	818	480	165	150	32,3	28,6
400	280	753 201 113	-	52.915	910	530	180	139	36,4	25,4
400	315	753 201 114	-	53.625	910	580	180	150	36,4	28,6
400	355	753 201 115	-	54.075	910	675	180	165	36,4	32,3

PF 2 51 301 004

Tee 90°, reduced LS with welded reducer

- PE 100 SDR 17 (ISO S8)
- 5 bar Gas / 10 bar Water

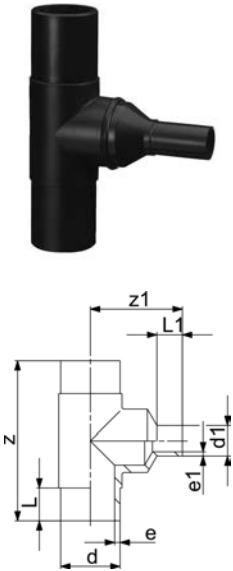

d	d1	Code	GP	kg	z	z1	L	L1	e	e1
[mm]	[mm]				[mm]	[mm]	[mm]	[mm]	[mm]	[mm]
125	63	753 200 801	4	2.115	366	215	92	61	7.4	3.8
125	75	753 200 810	6	2.140	366	235	92	72	7.4	4.5
125	90	753 200 811	8	2.180	366	235	92	80	7.4	5.4
140	75	753 200 812	4	2.820	396	240	92	70	8.3	4.5
140	90	753 200 822	4	2.855	396	240	92	78	8.3	5.4
140	110	753 200 823	4	2.910	396	235	92	82	8.3	6.6
140	125	753 200 824	2	2.955	396	240	92	87	8.3	7.4
160	125	753 200 825	4	3.970	428	265	104	90	9.5	5.4
160	140	753 200 826	4	4.070	428	280	104	96	9.5	8.3
180	110	753 200 827	2	5.250	460	285	105	92	10.7	6.6
180	125	753 200 845	2	5.070	460	285	105	90	10.7	7.4
180	140	753 200 846	-	5.290	460	305	105	110	10.7	8.3
200	125	753 200 847	1	7.100	500	310	115	92	11.9	7.4
200	140	753 200 848	-	7.200	500	315	115	110	11.9	8.3
200	180	753 200 849	-	6.900	500	315	115	110	11.9	10.7
225	125	753 200 850	1	8.620	540	320	122	92	13.4	7.4
225	140	753 200 855	-	8.780	540	345	122	110	13.4	8.3
225	200	753 200 856	-	9.300	540	335	122	115	13.4	11.9
250	180	753 200 857	1	15.000	576	340	130	105	14.8	10.7
250	200	753 200 858	-	15.440	576	350	130	112	14.8	11.9
250	225	753 200 859	1	15.620	576	370	130	120	14.8	13.4
280	200	753 200 860	-	19.200	616	400	139	112	16.6	11.9
280	225	753 200 861	-	19.500	616	400	139	120	16.6	13.4
280	250	753 200 862	-	20.120	616	400	139	130	16.6	14.8
315	200	753 200 863	-	18.700	690	480	150	134	18.7	11.9
315	280	753 200 864	-	26.940	690	480	150	139	18.7	16.6
355	250	753 200 865	-	35.770	818	480	165	130	21.1	14.8
355	280	753 200 866	-	36.330	818	480	165	139	21.1	16.6
355	315	753 200 867	-	37.740	818	490	165	150	21.1	18.7
400	280	753 200 868	-	48.330	910	540	180	139	23.7	16.6
400	315	753 200 869	-	48.880	910	580	180	150	23.7	18.7
400	355	753 200 870	-	50.020	910	675	180	165	23.7	21.1

PF 2 51 301 004

53 25 10

Tee 45°, equal Type L

- PE 100 SDR 11 (ISO S5)
- 10 bar Gas / 16 bar Water

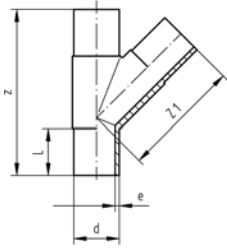

PF 2 51 301 001

d [mm]	Code	GP	kg	z [mm]	z1 [mm]	L [mm]	e [mm]
63	753 251 011	-	0.500	255	158	63	5,8
75	753 251 012	-	0.800	301	190	70	6,8
90	753 251 013	-	1.300	368	234	79	8,2
110	753 251 014	-	1.800	395	260	82	10,0

53 25 10

Tee 45°, equal Type L

- PE 100 SDR 17 (ISO S8)
- 5 bar Gas / 10 bar Water

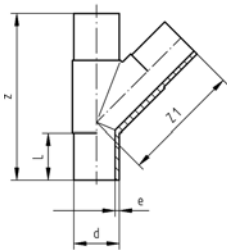

PF 2 51 301 001

d [mm]	Code	GP	kg	z [mm]	z1 [mm]	L [mm]	e [mm]
90	753 251 063	-	0.800	368	234	79	5,4
110	753 251 064	-	1.400	395	260	82	6,6

Reducer LS

- PE 100 SDR 11 (ISO S5)
- 10 bar Gas / 16 bar Water

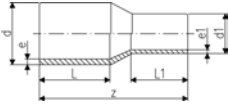

d	d1	Code	GP	kg	z	L	L1	e	e1
[mm]	[mm]				[mm]	[mm]	[mm]	[mm]	[mm]
25	20	753 901 038	40	0.022	115	52	52	3,0	3,0
32	20	753 901 042	50	0.028	120	54	52	3,0	3,0
32	25	753 901 041	45	0.031	120	54	52	3,0	3,0
40	20	753 901 048	40	0.040	130	57	52	3,7	3,0
40	25	753 901 047	50	0.043	130	57	52	3,7	3,0
40	32	753 901 046	40	0.047	130	57	53	3,7	3,0
50	20	753 901 055	20	0.064	150	63	52	4,6	3,0
50	25	753 901 054	45	0.066	140	63	52	4,6	3,0
50	32	753 901 053	40	0.067	140	63	53	4,6	3,0
50	40	753 901 052	25	0.079	140	63	57	4,6	3,7
63	32	753 901 060	28	0.109	150	65	53	5,8	3,0
63	40	753 901 059	28	0.119	150	65	57	5,8	3,7
63	50	753 901 058	24	0.130	150	65	63	5,8	4,6
75	40	753 901 063	18	0.178	170	72	57	6,8	3,7
75	50	753 901 064	18	0.191	170	72	63	6,8	4,6
75	63	753 901 065	15	0.216	170	72	65	6,8	5,8
90	50	753 901 072	15	0.291	190	81	63	8,2	4,6
90	63	753 901 071	20	0.317	190	81	65	8,2	5,8
90	75	753 901 070	17	0.361	190	81	70	8,2	6,8
110	63	753 901 078	10	0.469	205	86	65	10,0	5,8
110	75	753 901 077	10	0.497	205	86	70	10,0	6,8
110	90	753 901 076	9	0.557	205	86	81	10,0	8,2
125	63	753 901 083	-	0.579	214	87	63	11,4	5,8
125	75	753 901 082	8	0.660	210	92	72	11,4	6,8
125	90	753 901 081	6	0.735	212	92	81	11,4	8,2
125	110	753 901 080	6	0.819	212	92	86	11,4	10,0
140	75	753 901 086	-	0.560	230	110	70	12,7	6,8
140	90	753 901 087	-	0.690	230	110	79	12,7	8,2
140	110	753 901 084	-	0.820	230	110	88	12,7	10,0
140	125	753 901 085	12	0.988	235	110	90	12,7	11,4
160	90	753 901 088	-	1.060	244	120	79	14,6	8,2
160	110	753 901 090	5	1.240	244	102	86	14,6	10,0
160	125	753 901 089	5	1.403	245	102	92	14,6	11,4
160	140	753 901 032	10	1.350	260	120	110	14,6	12,7
180	90	753 901 073	-	1.530	245	105	79	16,4	8,2
180	110	753 901 074	-	1.720	270	105	82	16,4	10,0
180	125	753 901 091	4	1.753	255	107	92	16,4	11,4
180	140	753 901 075	-	1.980	270	120	110	16,4	12,7
180	160	753 901 033	4	2.044	255	107	102	16,4	14,6
200	140	753 901 066	-	2.310	275	120	110	18,2	12,7
200	160	753 901 092	6	2.472	265	117	102	18,2	14,6
200	180	753 901 034	-	2.580	265	117	107	18,2	16,4
225	140	753 901 067	-	2.900	295	130	110	20,5	12,7
225	160	753 901 096	3	3.118	279	122	102	20,5	14,6
225	180	753 901 095	4	3.277	280	122	107	20,5	16,4
225	200	753 901 094	4	3.538	280	122	117	20,5	18,2
250	160	753 901 000	-	2.385	300	130	100	22,7	14,6
250	180	753 901 068	-	4.050	295	130	105	22,7	16,4
250	200	753 901 001	-	2.385	315	130	112	22,7	18,2
250	225	753 901 002	-	2.385	332	130	120	22,7	20,5
280	200	753 901 098	-	6.850	333	140	112	25,4	18,2
280	225	753 901 099	-	6.090	335	140	120	25,4	20,5
280	250	753 901 003	-	2.385	340	140	130	25,4	22,7
315	200	753 901 004	-	2.385	380	180	134	28,6	18,2
315	225	753 901 097	-	7.790	365	150	120	28,6	20,5
315	250	753 901 005	-	2.385	365	150	130	28,6	22,7
315	280	753 901 012	-	8.800	365	150	139	28,6	25,4
355	250	753 901 013	-	9.100	390	165	130	32,3	22,7

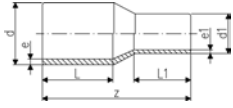

d [mm]	d1 [mm]	Code	GP	kg	z [mm]	L [mm]	L1 [mm]	e [mm]	e1 [mm]
355	280	753 901 014	-	9.500	390	165	139	32,3	25,4
355	315	753 901 015	-	9.900	390	165	150	32,3	28,6
400	280	753 901 016	-	10.420	415	180	139	36,4	25,4
400	315	753 901 017	-	11.130	415	180	150	36,4	28,6
400	355	753 901 018	-	11.600	420	180	165	36,4	32,3
450	280	753 901 019	-	16.200	389	195	139	40,9	25,4
450	315	753 901 020	-	16.700	390	195	150	40,9	28,6
450	355	753 901 022	-	17.500	393	195	164	40,9	32,3
450	400	753 901 024	-	18.500	395	195	179	40,9	36,4
500	315	753 901 025	-	21.900	422	212	150	45,5	28,6
500	355	753 901 026	-	22.600	424	212	164	45,5	32,3
500	400	753 901 027	-	23.600	426	212	179	45,5	36,4
500	450	753 901 029	-	25.100	428	212	195	45,5	40,9
560	355	753 901 030	-	30.100	459	230	164	50,9	32,3
560	400	753 901 039	-	31.000	461	230	179	50,9	36,4
560	450	753 901 040	-	32.400	463	230	195	50,9	40,9
560	500	753 901 043	-	34.100	466	230	212	50,9	45,5
630	400	753 901 044	-	41.900	502	250	179	57,3	36,4
630	450	753 901 045	-	43.100	503	250	195	57,3	40,9
630	500	753 901 049	-	44.700	506	250	212	57,3	45,5
630	560	753 901 050	-	46.800	506	250	230	57,3	50,9

PF 2 51 301 001

53 90 08

Reducer LS

- PE 100 SDR 17 (ISO S8)
- 5 bar Gas / 10 bar Water

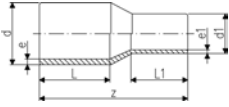

d	d1	Code	GP	kg	z	L	L1	e	e1	
[mm]	[mm]				[mm]	[mm]	[mm]	[mm]	[mm]	
90	63	753 900 872	-	0.216	182	79	70	5,4	3,8	
90	75	753 900 870	40	0.202	185	79	70	5,4	4,5	
110	63	753 900 877	-	0.326	185	82	63	6,6	3,8	
110	90	753 900 876	22	0.650	205	85	80	6,6	5,4	
125	63	753 900 882	-	0.610	200	87	63	7,4	3,8	
125	90	753 900 881	9	0.700	215	90	80	7,4	5,4	
125	110	753 900 880	9	0.810	215	90	85	7,4	6,6	
140	75	753 900 886	-	0.560	230	112	70	8,3	4,5	
140	90	753 900 887	-	0.610	230	112	79	8,3	5,4	
140	110	753 900 884	-	0.660	230	112	82	8,3	6,6	
140	125	753 900 885	12	0.712	235	115	87	8,3	7,4	
160	90	753 900 888	-	0.752	248	120	85	9,5	5,4	
160	110	753 900 890	10	9.970	245	100	85	9,5	6,6	
160	125	753 900 889	10	1.380	245	100	90	9,5	7,4	
160	140	753 900 831	10	1.380	260	120	110	9,5	8,3	
180	90	753 900 873	-	1.010	237	105	79	10,7	5,4	
180	110	753 900 874	-	1.600	270	120	92	10,7	6,6	
180	125	753 900 891	4	1.710	255	105	90	10,7	7,4	
180	140	753 900 875	-	1.720	270	120	110	10,7	8,3	
180	160	753 900 832	-	2.100	255	105	100	10,7	9,5	
200	140	753 900 866	-	1.800	275	120	110	11,9	8,3	
200	160	753 900 892	4	2.370	265	115	100	11,9	9,5	
200	180	753 900 893	4	2.580	265	115	105	11,9	10,7	
225	140	753 900 867	-	1.450	280	120	100	13,4	8,3	
225	160	753 900 896	4	2.980	280	120	100	13,4	9,5	
225	180	753 900 895	-	3.160	280	120	105	13,4	10,7	
225	200	753 900 894	8	3.750	280	120	115	13,4	11,9	
250	160	753 900 800	-	2.850	290	130	100	14,8	9,5	
250	180	753 900 868	-	3.100	295	130	105	14,8	10,7	
250	200	753 900 801	-	3.210	302	130	112	14,8	11,9	
250	225	753 900 802	6	2.385	332	162	120	14,8	13,4	
280	200	753 900 898	-	3.800	333	140	112	16,6	11,9	
280	225	753 900 899	-	4.100	335	140	120	16,6	13,4	
280	250	753 900 803	-	2.385	340	140	130	16,6	14,8	
315	200	753 900 804	-	6.200	380	180	134	18,7	11,9	
315	225	753 900 807	-	6.200	365	150	120	18,7	13,4	
315	250	753 900 805	-	6.420	365	150	130	18,7	14,8	
315	280	753 900 806	-	5.940	365	150	140	18,7	16,6	
355	250	753 900 808	-	5.270	390	165	130	21,1	14,8	
355	280	753 900 809	-	5.830	390	165	140	21,1	16,6	
355	315	753 900 810	-	7.240	390	165	150	21,1	18,7	
400	280	753 900 811	-	7.930	415	180	140	23,7	16,6	
400	315	753 900 812	-	8.480	415	180	150	23,7	18,7	
400	355	753 900 813	-	9.620	420	180	165	23,7	21,1	
450	280	753 900 814	-	11.500	389	195	140	26,7	16,6	
450	315	753 900 815	-	11.600	390	195	150	26,7	18,7	
450	355	753 900 816	-	11.900	393	195	164	26,7	21,1	
450	400	753 900 817	-	12.700	395	195	179	26,7	23,7	
500	315	753 900 818	-	15.500	422	212	150	29,7	18,7	
500	355	753 900 819	-	15.700	424	212	164	29,7	21,1	
500	400	753 900 820	-	16.200	426	212	179	29,7	23,7	
500	450	753 900 821	-	17.000	428	212	195	29,7	26,7	
560	355	753 900 822	-	21.400	459	230	164	33,2	21,1	
560	400	753 900 823	-	21.700	461	230	179	33,2	23,7	
560	450	753 900 824	-	22.300	463	230	195	33,2	26,7	
560	500	753 900 825	-	23.200	466	230	212	33,2	29,7	
630	400	753 900 826	-	29.700	502	250	179	37,4	23,7	
630	450	753 900 827	-	30.100	503	250	195	37,4	26,7	
630	500	753 900 828	-	30.800	506	250	212	37,4	29,7	
630	560	753 900 829	-	31.900	506	250	230	37,4	33,3	

PF 2 51 301 001

53 96 10

Cap Type L

- PE 100 SDR 11 (ISO S5)
- 10 bar Gas / 16 bar Water

Note:

- * Fabricated part using pipe

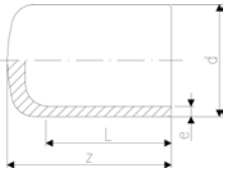

d [mm]	Code	GP	kg	z [mm]	L [mm]	e [mm]	
20	753 961 006	50	0.009	52	52	3,0	
25	753 961 007	50	0.013	52	52	3,0	
32	753 961 008	50	0.017	54	54	3,0	
40	753 961 009	50	0.031	57	57	3,7	
50	753 961 010	30	0.050	63	63	4,6	
63	753 961 011	24	0.085	65	65	5,8	
75	753 961 012	40	0.145	80	72	6,8	
90	753 961 013	18	0.240	90	81	8,2	
110	753 961 014	12	0.387	98	86	10,0	
125	753 961 015	12	0.546	105	92	11,4	
140	753 961 016	-	0.835	136	92	12,7	
160	753 961 017	8	1.026	120	102	14,6	
180	753 961 018	10	1.369	128	107	16,4	
200	753 961 019	5	1.839	138	115	18,2	
225	753 961 020	5	2.500	148	122	20,5	
250	753 961 021	-	3.927	205	130	22,7	
280	753 960 922	-	5.344	235	139	25,4	
315	753 960 923	-	7.176	255	150	28,6	
355	753 960 924	-	9.780	280	165	32,3	
400	753 960 925	-	13.370	310	180	36,4	
*450	753 960 926	-	20.800	275	195	40,9	
*500	753 960 927	-	28.400	297	212	45,5	
*560	753 960 928	-	39.100	325	230	50,9	
*630	753 960 929	-	59.700	355	250	57,3	

PF 2 51 301 001

53 96 08

Cap Type L

- PE 100 SDR 17 (ISO S8)
- 5 bar Gas / 10 bar Water

Note:

- * Fabricated part using pipe

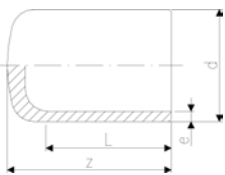

d [mm]	Code	GP	kg	z [mm]	L [mm]	e [mm]	
50	753 960 810	-	0.036	70	55	3,0	
63	753 960 811	-	0.066	82	63	3,8	
75	753 960 812	-	0.105	92	70	4,5	
90	753 960 813	18	0.220	90	81	5,4	
110	753 960 814	12	0.350	98	86	6,6	
125	753 960 815	12	0.520	105	92	7,4	
140	753 960 816	12	0.522	136	92	8,3	
160	753 960 817	8	0.990	120	102	9,5	
180	753 960 818	10	1.360	128	107	10,7	
200	753 960 819	5	1.880	138	115	11,9	
225	753 960 820	5	2.420	148	122	13,4	
250	753 960 821	-	2.547	205	130	14,8	
280	753 960 822	-	3.523	235	139	16,6	
315	753 960 823	-	4.758	255	150	18,7	
355	753 960 824	-	6.510	280	165	21,1	
400	753 960 825	-	9.330	310	180	23,7	
*450	753 960 826	-	15.800	265	195	26,7	
*500	753 960 827	-	21.400	287	212	29,7	
*560	753 960 828	-	29.400	310	230	33,2	
*630	753 960 829	-	41.400	340	250	37,4	

PF 2 51 301 001

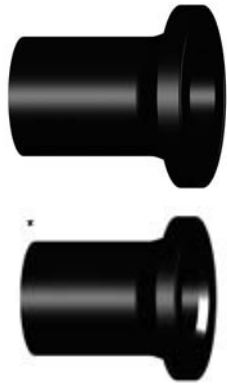

Flange Adaptor LS, PE100 SDR11

Combined Jointing Face: Flat and serrated



Model:

- For butt-, IR Plus® and electro fusion
- Suitable for flange connections to metric (from d110 also to ANSI/ASME B16.5)
- Up to d315, suitable for butterfly valve type 567, 568 and 037
- Gasket: Profile flange gasket NBR No. 45 44 07, EPDM No. 48 44 07
- 10 bar Gas / 16 bar Water

* Type B with chamfer

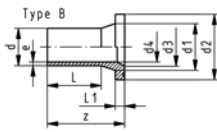
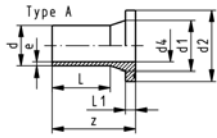

d [mm]	DN [mm]	FM	Code	GP	kg
20	15	IR	753 800 006	-	0.022
25	20	IR	753 800 007	-	0.034
32	25	IR	753 800 008	25	0.051
40	32	IR	753 800 009	60	0.076
50	40	IR	753 800 010	10	0.107
63	50	IR	753 800 011	30	0.174
*75	65	IR	753 800 012	18	0.301
*90	80	IR	753 800 013	12	0.441
*110	100	IR	753 800 014	8	0.685
*125	100	IR	753 800 015	12	0.836
*140	125	IR	753 800 016	6	1.295
*160	150	IR	753 800 017	6	1.644
*180	150	IR	753 800 018	2	1.873
*200	200	IR	753 800 019	8	2.758
*225	200	IR	753 800 020	4	2.972
*250	250		753 800 021	6	4.535
*280	250		753 800 022	5	4.925
*315	300		753 800 023	2	6.393
*355	350		753 800 024	2	10.400
*400	400		753 800 025	1	14.600
*450	500		753 800 026	-	24.800
*500	500		753 800 027	-	27.400
*560	600		753 800 028	-	38.000
*630	600		753 800 029	-	42.300

d [mm]	DN [mm]	z [mm]	d1 [mm]	d2 [mm]	d3 [mm]	d4 [mm]	L [mm]	L1 [mm]	e [mm]
20	15	85	27	45		16	41	7	1.9
25	20	85	33	58		20	41	9	2.3
32	25	85	40	68		26	44	10	3.0
40	32	85	50	78		32	49	11	3.7
50	40	104	61	88		40	55	12	4.6
63	50	98	75	102		51	65	14	5.8
*75	65	125	89	122	66	61	75	16	6.8
*90	80	140	105	138	78	73	85	17	8.2
*110	100	160	125	158	100	90	90	18	10.0
*125	100	170	132	158	114	102	95	25	11.4
*140	125	200	155	188	127	114	92	25	12.7
*160	150	200	175	212	151	130	110	25	14.6
*180	150	200	180	212	158	147	115	30	16.4
*200	200	200	232	268	203	163	120	32	18.2
*225	200	200	235	268	210	184	130	32	20.5
*250	250	220	285	320	245	204	130	35	22.7
*280	250	220	291	320	265	229	139	35	25.4
*315	300	230	335	370	300	257	150	35	28.6
*355	350	250	373	430	340	290	165	40	32.3
*400	400	280	427	482	385	327	180	46	36.4
*450	500	333	514	585	400	368	195	60	40.9
*500	500	350	530	585	440	409	212	60	45.5
*560	600	365	615	685	490	458	230	60	50.9
*630	600	385	642	685	545	515	250	60	57.3

PF 2 51 301 001

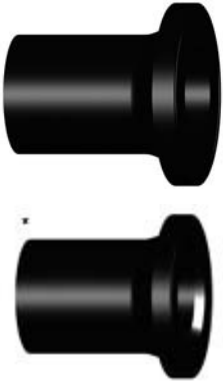

Flange Adaptor LS, PE100 SDR17/17.6 Combined Jointing Face: Flat and serrated



Model:

- For butt-, IR Plus® and electro fusion
- Suitable for flange connections to metric and ANSI B16.5
- Up to d315, suitable for butterfly valve type 567, 568 and 037
- Gasket: Profile flange gasket NBR No. 45 44 07, EPDM No. 48 44 07
- 5 bar Gas / 10 bar Water

* Type B with chamfer

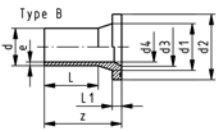
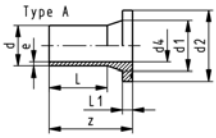

d [mm]	DN [mm]	FM	Code	GP	kg
50	40	IR	753 800 085	10	0.110
63	50	IR	753 800 086	32	0.143
75	65	IR	753 800 087	18	0.246
90	80	IR	753 800 088	20	0.351
110	100	IR	753 800 089	8	0.531
*125	100	IR	753 800 090	4	0.629
*140	125	IR	753 800 091	12	0.973
*160	150	IR	753 800 092	6	1.257
180	150	IR	753 800 093	4	1.364
*200	200	IR	753 800 094	4	2.212
*225	200	IR	753 800 095	4	2.233
*250	250		753 800 096	6	3.595
*280	250		753 800 097	5	3.355
*315	300		753 800 098	2	5.320
*355	350		753 800 099	2	7.300
*400	400		753 800 100	1	10.300
450	500		753 800 101	-	15.800
500	500		753 800 102	-	19.100
560	600		753 800 103	-	27.500
630	600		753 800 104	-	30.000

d [mm]	z [mm]	d1 [mm]	d2 [mm]	d3 [mm]	d4 [mm]	L [mm]	L1 [mm]	e [mm]
50	104	61	88		44	55	12	3.0
63	120	75	102		55	65	14	3.8
75	130	89	122		66	75	16	4.5
90	140	105	138		79	85	17	5.4
110	160	125	158		96	90	18	6.6
*125	170	132	158	114	110	95	25	7.4
*140	200	155	188	127	123	92	25	8.3
*160	200	175	212	158	141	110	25	9.5
180	200	180	212		158	115	30	10.7
*200	200	232	268	203	176	120	32	11.9
*225	200	235	268	210	198	130	32	13.4
*250	220	285	320	245	220	130	35	14.8
*280	220	291	320	265	246	139	35	16.6
*315	230	335	370	308	277	150	35	18.7
*355	250	373	430	340	312	165	40	21.1
*400	280	427	482	385	352	180	46	23.7
450	333	514	585		396	195	60	26.7
500	350	530	585		440	212	60	29.7
560	365	615	685		493	230	60	33.2
630	385	642	685		555	250	60	37.4

PF 2 51 301 001

Spigot Fittings for Butt Fusion PE 100

53 02 10

Bend 90°

- PE 100 SDR 11 (ISO S5)
- 10 bar Gas / 16 bar Water

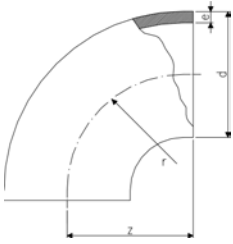

PF 2 51 301 005

d [mm]	Code	kg	z [mm]	r [mm]	e [mm]
250	753 021 021	6.270	285	255	22,7
280	753 021 022	8.580	290	260	25,4
315	753 021 023	9.830	340	300	28,6
355	753 021 024	17.200	335	300	32,3
400	753 021 025	23.000	349	300	36,4
450	753 021 026	38.300	450	400	40,9
500	753 021 027	47.300	450	400	45,5

53 02 08

Bend 90°

- PE 100 SDR 17 (ISO S8)
- 5 bar Gas / 10 bar Water

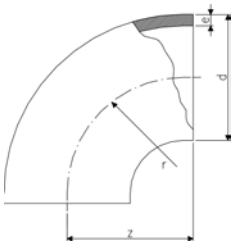

PF 2 51 301 005

d [mm]	Code	kg	z [mm]	r [mm]	e [mm]
250	753 020 821	3.940	285	240	14,2
280	753 020 822	5.660	290	280	15,9
315	753 020 823	6.680	335	300	17,9
355	753 020 824	11.300	340	300	21,1
400	753 020 825	15.700	345	300	23,7
450	753 020 826	24.900	450	400	26,7
500	753 020 827	30.600	450	400	29,7

53 22 10

Tee 90, equal

- PE 100 SDR 11 (ISO S5)
- 10 bar Gas / 16 bar Water

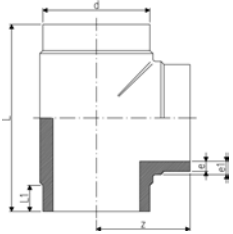

PF 2 51 301 003

d [mm]	Code	kg	z [mm]	L [mm]	L1 [mm]	e [mm]	
250	753 221 021	9.860	232	465	70	22,7	
280	753 221 022	13.750	270	540	82	25,4	
315	753 221 023	18.300	268	530	75	28,6	
355	753 221 024	30.500	352	665	97	32,3	
400	753 221 025	39.000	337	682	100	36,4	
450	753 221 026	45.000	450	900	130	40,9	
500	753 221 027	75.500	450	900	130	45,5	

53 22 08

Tee 90, equal

- PE 100 SDR 17 (ISO S8)
- 5 bar Gas / 10 bar Water

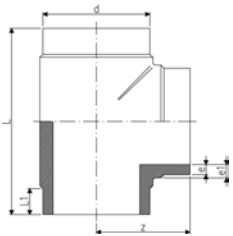

PF 2 51 301 003

d [mm]	Code	GP	kg	z [mm]	L [mm]	L1 [mm]	e [mm]	
250	753 220 821	-	6.900	232	465	70	14,8	
280	753 220 822	-	10.100	268	536	80	16,6	
315	753 220 823	-	14.000	263	530	75	18,7	
355	753 220 824	-	22.750	330	658	95	21,1	
400	753 220 825	-	30.500	345	690	104	23,7	
450	753 220 826	-	45.000	450	890	130	26,7	
500	753 220 827	-	52.600	445	890	130	29,7	

53 22 10

Tee 90°, reduced

- PE 100 SDR 11 (ISO S5)
- 10 bar Gas / 16 bar Water

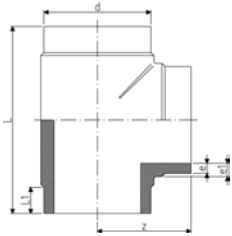

PF 2 51 301 004

d [mm]	d1 [mm]	Code	GP	kg	z [mm]	L [mm]	L1 [mm]	e [mm]
250	110	753 221 031	-	9.500	190	435	134	10
250	160	753 221 032	-	9.700	213	440	115	14,6

53 22 08

Tee 90°, reduced

- PE 100 SDR 17 (ISO S8)
- 5 bar Gas / 10 bar Water

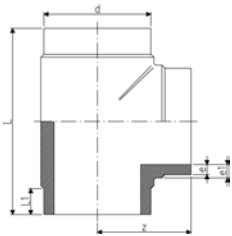

PF 2 51 301 004

d [mm]	d1 [mm]	Code	GP	kg	z [mm]	L [mm]	L1 [mm]	e [mm]
250	160	753 220 832	-	6.500	213	440	110	9,1

53 90 00

Reducer

- PE 100 SDR 11 (ISO S5)
- 10 bar Gas / 16 bar Water
- Up to d 315 injection moulded
- d 355 and above machined

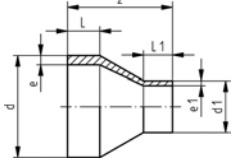

d [mm]	d1 [mm]	Code	kg	z [mm]	L [mm]	L1 [mm]	e [mm]	e1 [mm]
250	160	753 900 000	2.260	170	60	50	22,7	14,6
250	180	753 900 001	2.450	175	60	55	22,7	16,4
250	200	753 900 002	2.450	180	60	60	22,7	18,2
250	225	753 900 003	2.890	180	65	65	22,7	20,5
280	200	753 900 004	3.540	205	70	50	25,4	18,2
280	225	753 900 005	3.660	200	70	50	25,4	20,5
280	250	753 900 006	3.880	200	70	60	25,4	22,7
315	200	753 900 007	4.740	225	80	50	28,6	20,5
315	225	753 900 008	4.980	230	80	55	28,6	20,5
315	250	753 900 009	5.260	230	80	60	28,6	22,7
315	280	753 900 010	5.500	222	80	70	28,6	25,4
355	225	753 900 011	4.700	245	90	55	32,3	20,5
355	250	753 900 012	4.400	245	90	60	32,3	22,7
355	280	753 900 013	4.100	245	90	70	32,3	25,4
355	315	753 900 014	3.700	245	90	80	32,3	28,6
400	225	753 900 015	6.800	260	95	60	36,4	20,5
400	250	753 900 016	6.800	260	95	70	36,4	22,7
400	280	753 900 017	6.200	260	95	70	36,4	25,4
400	315	753 900 018	5.300	260	95	80	36,4	28,6
400	355	753 900 019	4.800	260	95	90	36,4	32,3
450	280	753 900 020	9.000	230	60	70	40,9	25,4
450	315	753 900 021	8.000	230	60	80	40,9	28,6
450	355	753 900 022	7.400	230	60	90	40,9	32,3
450	400	753 900 023	6.600	230	60	95	40,9	36,4
500	315	753 900 024	12.000	230	60	80	45,5	28,6
500	355	753 900 025	10.800	230	60	90	45,5	32,3
500	400	753 900 026	10.000	230	60	95	45,5	36,4
500	450	753 900 027	8.300	200	60	60	45,5	40,9

PF 2 51 301 003

53 90 28

Reducer

- PE 100 SDR 17 (ISO S8)
- 5 bar Gas / 10 bar Water
- Up to d 315 injection moulded
- d 355 and above machined

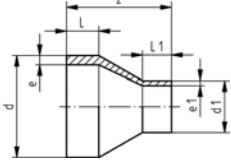

d	d1	Code	kg	z	L	L1	e	e1	
[mm]	[mm]			[mm]	[mm]	[mm]	[mm]	[mm]	
250	160	753 902 800	1.000	170	60	50	14,8	9,5	
250	180	753 902 801	1.690	175	60	55	14,8	10,7	
250	200	753 902 802	1.820	180	60	60	14,8	11,9	
250	225	753 902 803	2.030	180	65	65	14,8	13,4	
280	200	753 902 804	2.440	205	70	50	16,6	11,9	
280	225	753 902 805	2.560	200	70	50	16,6	13,4	
280	250	753 902 806	2.640	200	70	60	16,6	14,8	
315	200	753 902 807	3.360	225	80	50	18,7	11,9	
315	225	753 902 808	3.500	230	80	55	18,7	13,4	
315	250	753 902 809	3.580	230	80	60	18,7	14,8	
315	280	753 902 810	3.650	222	80	70	18,7	16,6	
355	225	753 902 811	4.700	245	90	55	21,1	13,4	
355	250	753 902 812	9.425	245	90	60	21,1	14,8	
355	280	753 902 813	4.100	245	90	70	21,1	16,6	
355	315	753 902 814	3.700	245	90	80	21,1	18,7	
400	225	753 902 815	4.600	260	95	60	23,7	13,4	
400	250	753 902 816	4.400	260	95	70	23,7	14,8	
400	280	753 902 817	4.400	260	95	70	23,7	16,6	
400	315	753 902 818	3.520	260	95	80	23,7	18,7	
400	355	753 902 819	3.320	260	95	90	23,7	21,1	
450	280	753 902 820	6.340	230	60	70	26,7	16,6	
450	315	753 902 821	5.400	230	60	80	26,7	18,7	
450	355	753 902 822	5.000	230	60	90	26,7	21,1	
450	400	753 902 823	4.400	230	60	95	26,7	23,7	
500	315	753 902 824	8.100	230	60	80	29,7	18,7	
500	355	753 902 825	7.300	230	60	90	29,7	21,1	
500	400	753 902 826	7.080	230	60	95	29,7	23,7	
500	450	753 902 827	5.500	200	60	60	29,7	26,7	
560	400	753 902 828	9.900	230	60	95	33,2	23,7	
560	450	753 902 829	8.600	200	60	60	33,2	26,7	
560	500	753 902 830	7.600	200	60	60	33,2	29,7	
630	400	753 902 831	15.100	230	60	95	37,4	23,7	
630	450	753 902 832	13.700	200	60	60	37,4	26,7	
630	500	753 902 833	12.000	200	60	60	37,4	29,7	
630	560	753 902 834	9.800	200	60	60	37,4	33,2	

PF 2 51 301 003

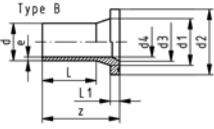

Flange Adaptors, PE100 S5/SDR11 Jointing Face, combination serrated / flat metric

Model:

- Conventional butt-welding according to DVS 2207 part 1
- Up to d315, suitable for butterfly valve type 567, 568 and 037
- Gasket: Profile flange gasket NBR No. 45 44 07, EPDM No. 48 44 07
- 10 bar Gas / 16 bar Water

d [mm]	DN [mm]	Code	GP	kg	z [mm]	d1 [mm]	d2 [mm]	d3 [mm]	d4 [mm]	L [mm]	L1 [mm]	e [mm]
250	250	753 798 826	14	2.420	120	285	320	245	204	45	35	22,7
280	250	753 798 827	5	2.800	115	291	320	265	229	70	35	25,4
315	300	753 798 828	6	3.350	120	335	370	300	257	55	35	28,6
355	350	753 798 829	4	7.800	118	373	430	340	290	40	40	32,2
400	400	753 798 830	2	10.700	140	427	482	385	327	55	46	36,3
450	500	753 798 831	14	12.550	138	514	585	400	368	44	60	40,9
500	500	753 798 832	14	11.780	138	530	585	440	409	48	60	45,4
560	600	753 798 833	9	-	135	615	684	490	458	20	60	50,8
630	600	753 798 834	9	-	135	642	684	545	516	40	60	57,2

PF 2 51 301 003

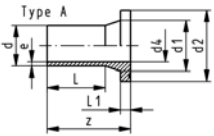

Flange Adaptors, PE100 S8,3/SDR 17.0 Jointing Face, combination serrated / flat metric

Model:

- Conventional butt-welding according to DVS 2207 part 1
- Up to d315, suitable for butterfly valve type 567, 568 and 037
- Gasket: Profile flange gasket NBR No. 45 44 07, EPDM No. 48 44 07
- 5 bar Gas / 10 bar Water

* Type B with chamfer

d [mm]	DN [mm]	Code	GP	kg	z [mm]	D1 [mm]	D2 [mm]	D3 [mm]	D4 [mm]	L [mm]	L1 [mm]	e [mm]
*250	250	753 798 851	14	1.830	120	285	320	245	220	56	25	14,8
*280	250	753 798 852	5	1.830	120	291	320	265	246	68	25	16,6
*315	300	753 798 853	6	1.830	120	335	370	300	277	60	25	18,7
*355	350	753 798 854	4	6.000	120	373	430	340	312	55	30	21,1
*400	400	753 798 855	2	8.100	140	427	482	385	352	67	33	23,7
450	500	753 798 856	14	9.070	140	514	585		396	60	46	26,7
500	500	753 798 857	14	7.870	140	530	585		440	45	46	29,7
560	600	753 798 858	9	12.310	140	615	685		493	46	50	33,2
630	600	753 798 859	9	10.520	140	642	685		555	60	50	37,4

PF 2 51 301 003

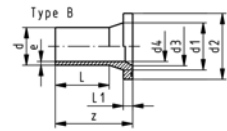

53 92 10

Reducer

- PE 100 SDR 11 (ISO S5)
- 10 bar Gas / 16 bar Water

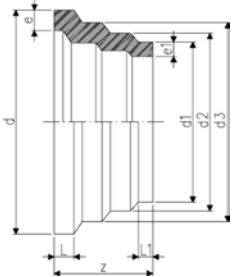

PF 2 51 301 003

d [mm]	d1 [mm]	Code	GP	kg	D2 [mm]	d2 [mm]	d3 [mm]	z [mm]	L [mm]	L1 [mm]	e [mm]	e1 [mm]
315	225	753 900 997	-	2.650	250	250	280	130	24	19	28,6	20,5
450	315	753 921 031	-	7.210	355	355	400	165	25	20	40,9	28,6

53 92 08

Reducer

- PE 100 SDR 17 (ISO S8)
- 5 bar Gas / 10 bar Water

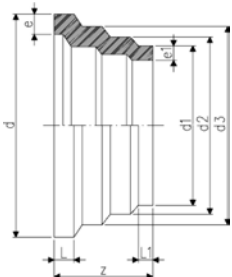

PF 2 51 301 003

d [mm]	d1 [mm]	Code	GP	kg	D2 [mm]	d2 [mm]	d3 [mm]	z [mm]	L [mm]	L1 [mm]	e [mm]	e1 [mm]
315	225	753 900 897	-	1.900	250	250	280	132	25	20	17,9	12,8
450	315	753 920 831	-	5.170	355	355	400	165	25	20	25,5	17,9
630	450	753 920 832	-	9.950	500	500	560	196	37	21	35,7	25,5

Reducer excentric

- PE 100 SDR 11 (ISO S5)
- 10 bar Gas / 16 bar Water

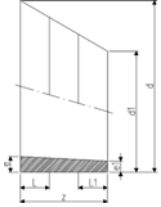

PF 2 51 301 003

d [mm]	d1 [mm]	Code	kg	z [mm]	e [mm]	e1 [mm]	
250	160	753 931 031	1.200	155	22,8	14,6	
355	250	753 931 098	3.500	200	32,3	22,8	

Reducer, excentric

- PE 100 SDR 17 (ISO S8)
- 5 bar Gas / 10 bar Water

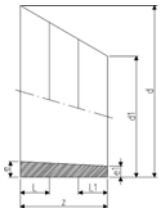

PF 2 51 301 003

d [mm]	d1 [mm]	Code	kg	z [mm]	e [mm]	e1 [mm]	
250	160	753 930 831	1.000	155	14,2	9,1	
355	250	753 930 898	2.300	200	20,1	14,2	



Hydrants

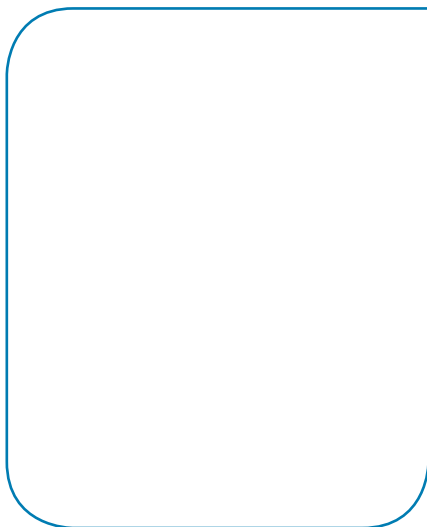



Hydrant



- PE-Hydrant
- PE 100 SDR 11 (ISO S5)
- Undergroundhydrant
- 16 bar Water
- PE spigot d90 mm SDR11
- For pipe covers according to DIN 3221
- Polystyrene drainage element available under 193.281.465

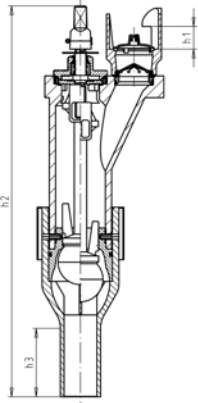

d [mm]	Code	GP	kg	RD [m]	H1 [mm]	H2 [mm]	H3 [mm]
90	193 281 200	1	18.500	1.00	50	881	150
90	193 281 201	1	19.800	1.25	50	1131	150
90	193 281 202	1	21.000	1.50	50	1381	150

PF 2 51 697 001



Hydrant



- PE-Hydrant
- PE 100 SDR 11 (ISO S5)
- 16 bar Water
- PP/steel loose flange acc. DIN 2501
- For pipe covers according to DIN 3221
- Polystyrene drainage element available under 193.281.465

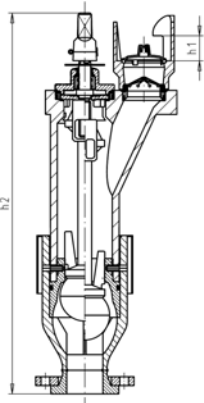

DN [mm]	Code	GP	kg	RD [m]	H1 [mm]	H2 [mm]
80	193 281 300	1	20.500	1.00	50	774
80	193 281 301	1	21.800	1.25	50	1024
80	193 281 302	1	23.100	1.50	50	1274

PF 2 51 697 001



Hydrant Kit for lateral shifted connection



- PE 100 SDR 11 (ISO S5)
- 16 bar Water
- 4 mm pin connector
- Limited path fusion indicator
- Flange dimensions according to DIN 2501/BS 4504
- For pipe covers according to DIN 3221

Kit consists of:

ELGEF Plus Branch Fitting

ELGEF Plus MMN-Duckfoot Bend d90

PE-Flange adaptor d90 SDR 11

PP-V Backing flange d90 DN 80

Flange seal NBR DN 80

d [mm]	DN [mm]	Code	GP	kg	
110	80	193 281 214	1	3.751	
125	80	193 281 215	1	3.811	
160	80	193 281 217	1	4.121	
180	80	193 281 218	1	4.391	

PF 2 51 697 002



Hydrant Kit for direct connection



- PE 100 SDR 11 (ISO S5)
- 16 bar Water
- 4 mm pin connectors
- Limited path fusion indicators
- Flange dimensions according to DIN 2501/BS 4504
- For pipe covers according to DIN 3221

Kit consists of:

ELGEF Plus Branch Fitting

PE-flange adaptor d90 SDR 11

PP-V Backing flange d90 DN 80

Flange seal NBR DN 80

d [mm]	DN [mm]	Code	GP	kg	
110	80	193 281 204	1	2.141	
125	80	193 281 205	1	2.201	
160	80	193 281 207	1	2.511	
180	80	193 281 208	1	2.781	

PF 2 51 697 002



Duckfoot Bend MMN - Piece



- PE 100 SDR 11 (ISO S5)
- 16 bar Water
- Fitted with welded base plate for a better stability
- 4 mm pin connectors
- Limited path fusion indicators
- For pipe covers according to DIN 3221

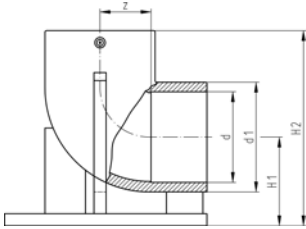

PF 2 51 697 002

d [mm]	Code	GP	kg	d1 [mm]	H1 [mm]	H2 [mm]	
90	193 281 102	1	1.610	113	95	205	
110	193 281 103	1	2.490	136	109	240	



Duckfoot Bend (Kit) EN - piece



- PE 100 SDR 11 (ISO S5)
- 16 bar Water
- With flange outlet DN 80 and integrated service outlet d63
- Delivered with ELGEF® Plus Coupler
- For pipe covers according to DIN 3221
- Flange dimensions according to DIN 2501/BS 4504
- O-ring seal at flange front side
- Backing flange material GGG40

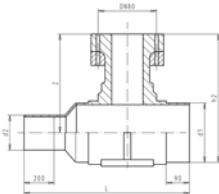

PF 2 51 697 002

d [mm]	Code	GP	kg	d1 [mm]	H1 [mm]	H2 [mm]	L [mm]	DN [mm]	
90	193 281 147	1	7.330	63	205	275	690	80	
110	193 281 148	1	6.450	63	205	275	690	80	



Pipe Support

- PE
- For mainlines d 90 up to d 160
- Rubber coated bearing surface
- Delivered with fixation belts

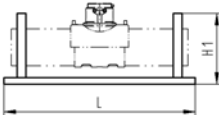

PF 2 51 697 002

d [mm]	Code	GP	kg	L [mm]	H1 [mm]	
90 - 160	193 281 105	1	2.480	435	160	

Flange

27 70 02
27 70 03

Backing Flanges, PP/Steel for Butt Fusion Systems metric

Model:

- Material: PP (30 % glass-fibre reinforced) with steel ring
- Connecting dimension: ISO 7005, EN 1092, BS 4504, DIN 2501; bolt circle PN 10

AL: number of holes

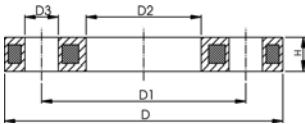
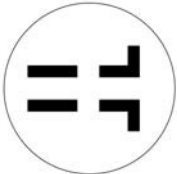

d [mm]	d [inch]	DN [mm]	PN	Code	kg	D [mm]	D1 [mm]	D2 [mm]	D3 [mm]	H [mm]	AL	SC
20		15	16	727 700 206	0.220	95	65	28	14	12	4	M12
25		20	16	727 700 207	0.260	105	75	34	14	12	4	M12
32		25	16	727 700 208	0.430	115	85	42	14	16	4	M12
40		32	16	727 700 209	0.650	140	100	51	18	16	4	M16
50		40	16	727 700 210	0.820	150	110	62	18	18	4	M16
63		50	16	727 700 211	0.940	165	125	78	18	18	4	M16
75		65	16	727 700 212	1.300	185	145	92	18	18	4	M16
90		80	16	727 700 313	1.400	200	160	108	18	20	8	M16
110		100	16	727 700 314	1.580	220	180	128	18	20	8	M16
125		100	16	727 700 315	1.550	220	180	135	18	20	8	M16
140		125	16	727 700 316	2.360	250	210	158	18	24	8	M16
160	6	150	16	727 700 317	3.890	285	240	178	22	24	8	M20
180		150	16	727 700 318	3.410	285	240	188	22	24	8	M20
200		200	16	727 700 319	5.180	340	295	235	22	27	8	M20
225		200	16	727 700 320	5.150	340	295	238	22	27	8	M20
250		250	16	727 700 321	6.680	395	350	288	22	30	12	M20
280		250	16	727 700 322	6.580	395	350	294	22	30	12	M20
315		300	16	727 700 323	8.420	445	400	338	22	34	12	M20
355		350	16	727 700 324	15.790	515	460	376	22	40	16	M20
400		400	16	727 700 325	19.320	574	515	430	26	40	16	M24

PF 2 34 238 022

24 70 04

Profiled Backing Flanges, PP/Steel for Butt Fusion Systems metric

Model:

- PP with glass-fibre reinforcement and GGG 50 insert
- Connecting dimensions: ISO 7005, EN 1092, DIN 2501
- **Bolt circle PN 10**

AL: number of holes

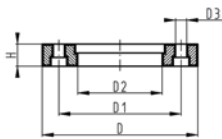

d [mm]	DN [mm]	PN	Code	kg	D [mm]	D1 [mm]	D2 [mm]	D3 [mm]	H [mm]	AL	SC
355	350	10	724 700 424	15.570	521	460	376	22	48	16	M20
400	400	10	724 700 425	19.800	582	515	430	26	51	16	M24
450	500	10	724 700 426	25.600	684	620	517	26	49	20	M24
500	500	10	724 700 427	24.300	684	620	533	26	49	20	M24
560	600	10	724 700 428	35.700	796	725	618	30	58	20	M27
630	600	10	724 700 429	32.500	796	725	645	30	68	20	M27

PF 2 55 337 003

24 70 03

Profiled Backing Flanges, PP/Steel for Butt Fusion Systems metric

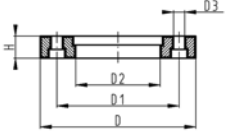

Model:

- PP with glass-fibre reinforcement and GGG 50 insert
- Connecting dimensions: ISO 7005, EN 1092, DIN 2501
- **Bolt circle PN 16**

AL: number of holes

d [mm]	DN [mm]	PN	Code	kg	D [mm]	D1 [mm]	D2 [mm]	D3 [mm]	H [mm]	AL	SC
200	200	16	724 700 319	3.720	344	295	235	22	28	12	M20
225	200	16	724 700 320	3.320	344	295	238	22	28	12	M20
250	250	16	724 700 321	6.390	405	355	288	26	31	12	M24
280	250	16	724 700 322	6.310	405	355	294	26	31	12	M24
315	300	16	724 700 323	9.740	465	410	338	26	38	12	M24
355	350	16	724 700 324	16.300	532	470	376	26	48	16	M24
400	400	16	724 700 325	20.600	594	525	430	30	54	16	M27

PF 2 55 337 003

01 48 04

Backing Flanges, Steel for Butt Fusion Systems metric

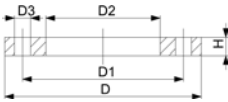

Model:

- Galvanized steel, suitable for underground laying
- Connecting dimensions: ISO 7005, EN 1092, DIN 2501
- **Bolt circle PN 16**

AL: number of holes

d [mm]	DN [mm]	PN	Code	kg	D [mm]	D1 [mm]	D2 [mm]	D3 [mm]	H [mm]	AL	SC
32	25	16	701 474 390	0.830	115	85	42	14	12	4	M12
40	32	16	701 474 391	1.430	140	100	51	18	14	4	M16
50	40	16	701 474 392	1.530	150	110	62	18	14	4	M16
63	50	16	701 474 393	1.840	165	125	78	18	16	4	M16
75	65	16	701 474 394	2.150	185	145	92	18	16	8	M16
90	80	16	701 474 395	2.830	200	160	108	18	18	8	M16
110	100	16	701 474 396	3.300	220	180	128	18	18	8	M16
125	100	16	701 474 397	3.170	220	180	135	18	18	8	M16
125	125	16	701 474 386	3.500	250	210	135	18	25	8	M16
140	125	16	701 474 387	4.100	250	210	158	18	18	8	M16
160	150	16	701 474 382	5.440	285	240	178	22	20	8	M20
180	150	16	701 474 398	5.180	285	240	188	22	20	8	M20
200	200	16	701 480 475	8.000	340	295	235	22	24	12	M20
225	200	16	701 480 476	7.810	340	295	238	22	24	12	M20
250	250	16	701 480 477	8.120	405	355	288	26	30	12	M24
280	250	16	701 480 478	8.320	405	355	294	26	30	12	M24
315	300	16	701 480 479	9.850	460	410	338	26	34	12	M24
355	350	16	701 480 480	10.500	520	470	376	26	35	16	M24
400	400	16	701 480 481	24.400	580	525	430	30	38	16	M27
450	500	16	701 480 482	37.000	715	650	517	33	46	20	M30
500	500	16	701 480 483	32.000	715	650	533	33	46	20	M30

PF 2 90 703 005

01 47 43

Backing Flanges, Steel for Butt Fusion Systems metric

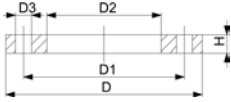

Model:

- Galvanized steel, suitable for underground laying
- Connecting dimensions: ISO 7005, EN 1092, DIN 2501
- **Bolt circle PN 10**

AL: number of holes

d	DN	PN	Code	kg	D	D1	D2	D3	H	AL	SC	
[mm]	[mm]				[mm]	[mm]	[mm]	[mm]	[mm]			
200	200	10	701 474 383	6.630	340	295	235	22	22	8	M20	
225	200	10	701 474 388	6.580	340	295	238	22	22	8	M20	
250	250	10	701 474 399	8.120	395	350	288	22	30	12	M20	
280	250	10	701 474 400	8.320	395	350	294	22	30	12	M20	
315	300	10	701 474 401	9.850	445	400	338	22	34	12	M20	
500	500	10	701 480 492	32.000	670	620	533	26	38	20	M24	
560	600	10	701 480 493	56.300	780	725	618	30	42	20	M27	
630	600	10	701 480 494	47.200	780	725	645	30	42	20	M27	

PF 2 90 703 005

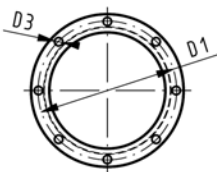
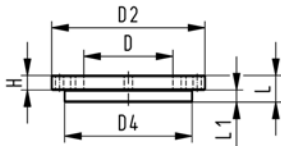

Blanking Flange Set, PE Combined Jointing face flat and serrated metric



Model:

- d63 - d315: Backing Flange PP-V with End Blank PE
- d355 - d630: Backing Flange PP/Steel with End Blank PE
- Connecting dimensions: ISO 7005, EN 1092, DIN 2501

AL: number of holes

L: length of the End Blank

d	DN	PN	Code Code	kg	D	D1	D2	D3	D4	H	L	L1	AL	
[mm]	[mm]				[mm]	[mm]	[mm]	[mm]	[mm]	[mm]	[mm]	[mm]		
63	50	16	753 700 611	0.674	75	125	165	18	102	24	30	14	4	
75	65	16	753 700 612	0.910	89	145	185	18	122	26	30	16	4	
90	80	16	753 700 613	1.067	105	160	200	18	138	27	30	17	8	
110	100	16	753 700 614	1.216	125	180	220	18	158	28	30	18	8	
125	100	16	753 700 615	1.678	132	180	220	18	158	28	35	25	8	
140	125	16	753 700 616	1.913	155	210	250	18	188	30	40	25	8	
160	150	16	753 700 617	2.352	175	240	285	22	212	32	40	25	8	
180	150	16	753 700 618	2.430	180	240	285	22	212	32	45	30	8	
200	200	16	753 700 619	3.495	232	295	340	22	268	34	50	32	8	
225	200	16	753 700 620	3.744	235	295	340	22	268	34	50	32	8	
250	250	16	753 700 621	5.558	285	350	395	22	320	38	55	35	12	
280	250	16	753 700 622	19.957	291	350	395	22	320	38	60	35	12	
315	300	16	753 700 623	24.569	335	400	445	22	370	42	65	35	12	
355	350	16	753 700 624	23.198	373	460	515	22	430	40	70	40	16	
400	400	16	753 700 625	30.766	427	515	574	26	482	40	75	46	16	
450	500	10	753 700 626	44.271	510	620	684	26	585	49	80	60	20	
500	500	10	753 700 627	47.165	530	620	684	26	585	49	90	60	20	
560	600	10	753 700 628	67.147	615	725	796	30	685	58	100	60	20	
630	600	10	753 700 629	68.574	642	725	796	30	685	58	110	60	20	

PF 2 34 238 038

Flat Gasket EPDM



Model:

- For all GF Flange Adaptors
- Hardness : EPDM ca. 70° Shore
- Integrated fixation aids from d110

di FA are the suitable inner diameters of flange adaptors

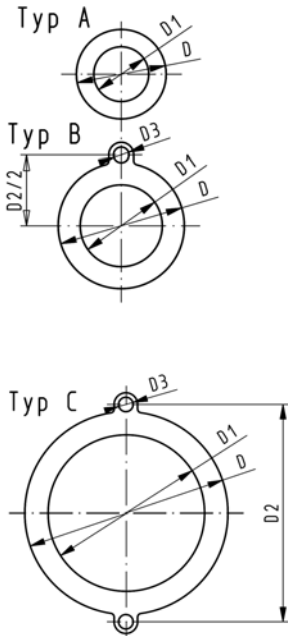

PF 2 30 162 003

d [mm]	DN [mm]	PN	Type	EPDM Code	kg	D [mm]	D1 [mm]	D2 [mm]	D3 [mm]	H [mm]	di FA [mm]
16	10	10	A	748 400 305	0.005	46	16			2	6 - 26
20	15	10	A	748 400 306	0.010	51	20			2	10 - 30
25	20	10	A	748 400 307	0.020	61	25			2	15 - 35
32	25	10	A	748 400 308	0.025	71	32			2	22 - 42
40	32	10	A	748 400 309	0.030	82	40			3	30 - 50
50	40	10	A	748 400 310	0.035	92	50			3	40 - 60
63	50	10	A	748 400 311	0.040	107	63			3	53 - 73
75	65	10	A	748 400 312	0.045	127	71			3	61 - 81
90	80	10	A	748 400 313	0.050	142	84			3	74 - 94
110	100	10	B	748 400 314	0.032	162	104	180	18	4	94 - 114
125	100	10	B	748 400 315	0.058	162	119	180	18	4	109 - 129
140	125	10	B	748 400 316	0.062	192	134	210	18	4	124 - 144
160 / 180	150	10	B	748 400 317	0.068	218	155	241	22	4	145 - 165
200	200	6	C	748 400 319	0.075	273	195	295	22	5	185 - 205
225	200	6	C	748 400 320	0.079	273	216	295	22	5	206 - 226
250	250	6	C	748 400 321	0.103	328	250	350	22	5	240 - 260
280	250	6	C	748 400 322	0.150	328	273	350	22	5	263 - 283
315	300	6	C	748 400 323	0.230	378	305	400	22	5	295 - 315

Profile Flange Gaskets metric NBR/DUO

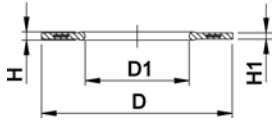

Model:

- For all GF Flange Adaptors
- Profile Gasket with steel insert (type G-ST-P/K)
- NBR/DUO = Nitrile rubber, hardness approx. 80° Shore
- Suitable for drinking water and gas applications
- Approved acc. to DVGW standard DIN EN 682
- Approved acc. to DVGW W 270, KTW recommendation
- d corresponds to the centring at the inner diameter of the screw crown

di FA are the suitable inner diameters of flange adaptors

d [mm]	DN [mm]	PN	NBR/DUO Code	kg	D [mm]	D1 [mm]	H [mm]	H1 [mm]	di FA [mm]
20	15	16	745 440 706	0.008	51	20	4	3	10 - 20
25	20	16	745 440 707	0.011	61	22	4	3	12 - 22
32	25	16	745 440 708	0.014	71	28	4	3	18 - 28
40	32	16	745 440 709	0.021	82	40	4	3	30 - 40
50	40	16	745 440 710	0.022	92	46	4	3	36 - 46
63	50	16	745 440 711	0.041	107	58	5	4	48 - 58
75	65	16	745 440 712	0.055	127	69	5	4	59 - 69
90	80	16	745 440 713	0.062	142	84	5	4	73 - 84
110	100	16	745 440 714	0.085	162	104	6	5	94 - 104
125	100	16	745 440 715	0.158	162	123	6	5	113 - 123
140	125	16	745 440 716	0.118	192	137	6	5	127 - 137
160 / 180	150	16	745 440 717	0.153	218	160	8	6	150 - 160
200	200	16	745 440 719	0.263	273	203	8	6	192 - 203
225	200	16	745 440 720	0.181	273	220	8	6	207 - 220
250	250	16	745 440 721	0.410	328	252	8	6	238 - 252
280	250	16	745 440 722	0.226	328	274	8	6	264 - 274
315	300	16	745 440 723	0.334	378	306	8	6	296 - 306
355	350	16	745 440 724	0.410	438	355	10	7	340 - 355
400	400	16	745 440 725	0.513	489	400	10	7	385 - 400
450	500	16	745 440 726	0.718	594	403	10	7	393 - 403
500	500	16	745 440 727	0.718	594	447	10	7	437 - 447
560	600	16	745 440 728	0.923	695	494	10	7	484 - 494
630	600	16	745 440 729	0.923	695	555	10	7	545 - 555

PF 2 55 338 003

EPDM 48 44 07
FPM 49 44 07

Profile Flange Gaskets metric EPDM / FPM

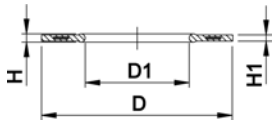

Model:

- For all GF Flange Adaptors
- Profile Gasket with steel insert (type G-ST-P/K)
- Hardness: 70° Shore **EPDM**, 75° Shore **FPM**

di FA are the suitable inner diameters of flange adaptors

d [mm]	DN [mm]	PN	EPDM Code	FPM Code	kg	D [mm]	D1 [mm]	H [mm]	H1 [mm]	di FA [mm]
16	10	16	748 440 705	749 440 705	0.007	46	16	4	3	6 - 16
20	15	16	748 440 706	749 440 706	0.008	51	20	4	3	10 - 20
25	20	16	748 440 707	749 440 707	0.011	61	22	4	3	12 - 22
32	25	16	748 440 708	749 440 708	0.014	71	28	4	3	18 - 28
40	32	16	748 440 709	749 440 709	0.021	82	40	4	3	30 - 40
50	40	16	748 440 710	749 440 710	0.022	92	46	4	3	36 - 46
63	50	16	748 440 711	749 440 711	0.041	107	58	5	4	48 - 58
75	65	16	748 440 712	749 440 712	0.055	127	69	5	4	59 - 69
90	80	16	748 440 713	749 440 713	0.062	142	84	5	4	73 - 84
110	100	16	748 440 714	749 440 714	0.085	162	104	6	5	94 - 104
125	100	16	748 440 715	749 440 715	0.158	162	123	6	5	113 - 123
140	125	16	748 440 716	749 440 716	0.118	192	137	6	5	127 - 137
160 / 180	150	16	748 440 717	749 440 717	0.153	218	160	8	6	150 - 160
200	200	16	748 440 719	749 440 719	0.263	273	203	8	6	192 - 203
225	200	16	748 440 720	749 440 720	0.181	273	220	8	6	207 - 220
250	250	16	748 440 721	749 440 721	0.410	328	252	8	6	238 - 252
280	250	16	748 440 722	749 440 722	0.226	328	274	8	6	264 - 274
315	300	16	748 440 723	749 440 723	0.334	378	306	8	6	296 - 306
355	350	16	748 440 724	749 440 724	0.410	438	355	10	7	340 - 355
400	400	16	748 440 725	749 440 725	0.513	489	400	10	7	385 - 400
450	500	16	748 440 726	749 440 726	0.718	594	403	10	7	393 - 403
500	500	16	748 440 727	749 440 727	0.718	594	447	10	7	437 - 447
560	600	16	748 440 728	749 440 728	0.923	695	494	10	7	484 - 494
630	600	16	748 440 729	749 440 729	0.923	695	555	10	7	545 - 555

PF 2 30 162 037

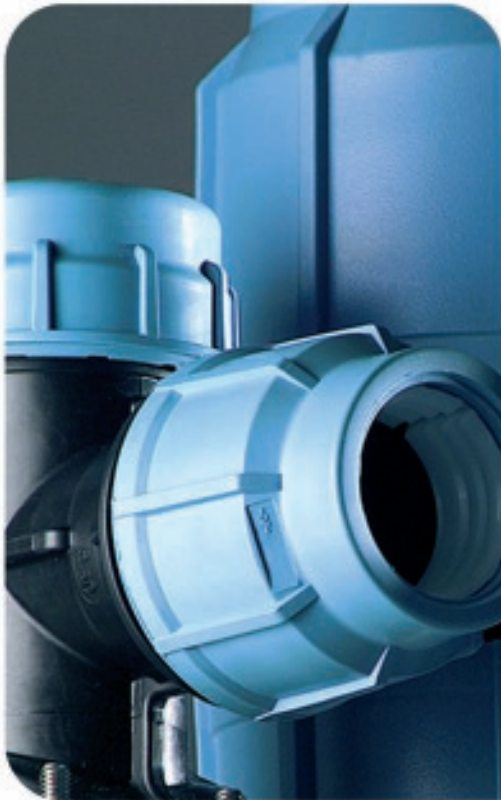

POLY16 Plus Compression fittings

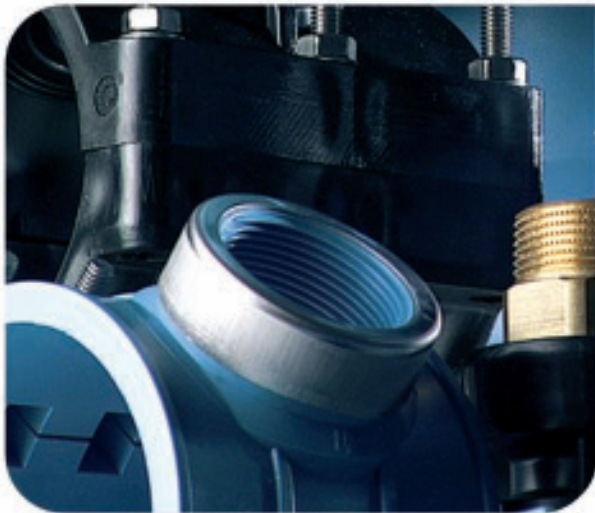

POLY16 Plus Compression fittings

Technical informations

Materials

Body, Thrust ring:

polypropylene copolymer stabilized (PP-B), UV stabilized

Nut:

polypropylene copolymer stabilized (PP-B) with Master Batches UV stabilized (Grade 8, ASTM D2565, 1-8)

Clamp ring:

Acetalic resin (POM)

Gasket:

Food safe rubber (NBR and special NBR KTW approved); 70 sh

Reinforcement ring:

Stainless Steel AISI 430 (for female thread from 1"1/4 to 4")

Standards

For PE pipe:

DIN 8072/8074; EN 12201; AZ/NZS4130; BS 6572; BS 6730; ISO 4427; UNI 7990

Threads:

Male and female threads (pressure tight) ISO7/1; DIN 2999/1; BS21; AZ/NZS1722.1

Flanges:

DIN 2501/8063; ISO 7005

Test Standards

ISO 3458, 3459, 3501-3503; UNI 9561; UNI 9562; DIN 8076-3; ISO 14236.2; AZ/NZS4129

Nominal Pressure PFA (PN):

See single article tables

Colour

Body, Thrust ring, Rubber: black

Nut: blue (RAL 5012)

Clamp ring: white



POLY16 Plus Clamp saddles

Technical informations

Materials

Body:

polypropylene copolymer stabilized (PP-B) with Master Batches UV stabilized (Grade 8, ASTM D2565, 1-8)

Gasket:

Food safe rubber (NBR); 70 sh

Reinforcement ring:

Stainless Steel AISI 430

Bolts and nuts:

galvanized or stainless steel

Standards

For PE pipe:

ISO 3607; DIN 8072/8074; AS/NZS4130; EN 12201-2; BS 6572; BS 6730; ISO 4427; UNI 7990

For PVC pipe:

UNI EN 1452

Threads:

ISO 7/1; DIN 2999/1; BS21; AS1722.1

Type 174X: brass insert

Test Standards:

ISO 13460; AZ/NZS4129

Nominal Pressure PFA (PN):

See single article tables

Sanitary requirements

Clamp saddles suitable for drinking water according to standards and regulation currently in force in Italy (Circolare n. 102 - 02.12.1978 Ministry of Health and DM -21.03.1973), D.M num. 174 - 06 Aprile 2004, Germany (Mitteilungen aus dem Bundes-gesundheitsamt, 108./109. Mitteilung), United Kingdom (WRAS), Netherlands (KIWA), USA (NSF).

Poly16 Plus compression fittings

Assembly instructions

Ø 16 - 63

Before proceeding with the assembly, please check the presence of all components (seal, thrust ring, clamp ring)

1. Cut the pipe square and deburr it (for an easier assembly chamfer the pipe). Greas the seal, in case it is dry. Loosen the nut partially
 2. Push the pipe into the fitting through the clamp ring until the first stop, meaning you have reached the seal.
 3. Push the pipe through the seal until you reach the pipe stop of the fitting.
- Note:** For extra safety, mark the pipe (see table: "insert depth"); the mark on the pipe doesn't have to be visible when the nut will be tightened.
4. Tighten the nut as tightly as possible. Up to diameter d.32 manual tightening or mechanical tightening using special +GF+ keys or suitable standard tools; from diameter d.4 mechanical tightening using special +GF+ keys or suitable standard tools.

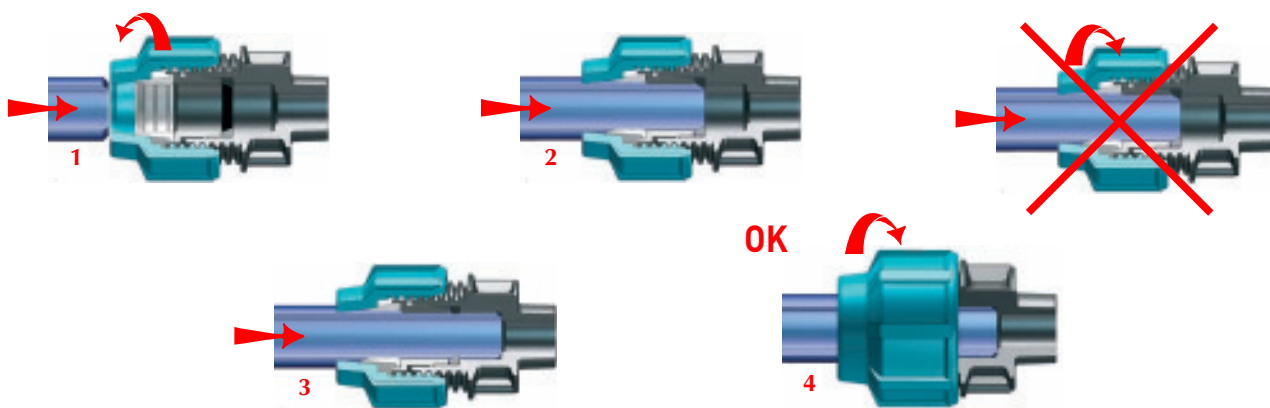

Ø 75 - 110

Before proceeding with the assembly, please check the presence of all the components (seal, thrust ring, clamp ring)

1. Cut the pipe square and deburr it (no chamfering). Loosen the nut slightly.
2. Push the pipe into the fitting until you have reached the pipe stop.
3. Tighten the nut as tightly as possible using special +GF+ keys.

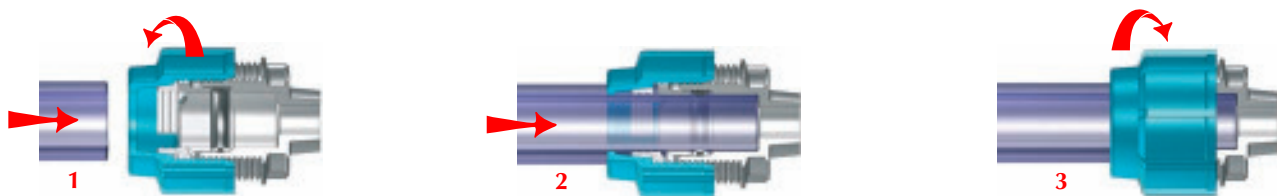

INSERT DEPTH

Ø	mm
16	45
2	45
25	5
32	55
4	7
5	75
63	95

POLY16 Plus COMPRESSION FITTINGS

27 92 63

Male adaptor

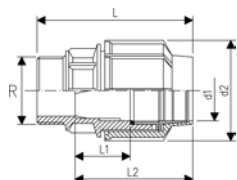

- active sealing system (with thrust ring); d16-63 double lip gasket; d75-110 spring gasket
- installation without disassembling
- suitable for PE and PEX-a pipes
- water PN16
- material: PP
- gasket: NBR quality for drinkable water
- male thread: ISO 7 (conical)
- colour: blue-black

d	R	PN	Code	GP	kg	d1	d2	L	L1	L2	
[mm]	[inch]					[mm]	[mm]	[mm]	[mm]	[mm]	
16	1/2	16	727 926 329	350	0.045	22	46	76	20	58	
16	3/4	16	727 926 330	325	0.047	22	46	76	20	58	
20	1/2	16	727 926 306	350	0.043	22	46	76	16	56	
20	3/4	16	727 926 333	325	0.045	22	46	77	15	55	
20	1	16	727 926 332	300	0.049	22	46	79	15	55	
25	1/2	16	727 926 337	200	0.067	28	57	80	18	62	
25	3/4	16	727 926 307	200	0.068	28	57	82	18	62	
25	1	16	727 926 336	200	0.070	28	57	86	18	64	
32	3/4	16	727 926 341	125	0.103	34	67	89	20	68	
32	1	16	727 926 308	125	0.105	34	67	92	20	68	
32	1 1/4	16	727 926 340	125	0.107	34	67	94	20	70	
32	1 1/2	16	727 926 339	125	0.108	34	67	93	20	68	
40	1	16	727 926 346	-	0.207	44	82	113	28	87	
40	1 1/4	16	727 926 309	-	0.208	44	82	115	28	87	
40	1 1/2	16	727 926 345	-	0.212	44	82	115	27	87	
40	2	16	727 926 347	-	0.219	44	82	115	27	87	
50	1	16	727 926 353	-	0.278	54	93	125	30	99	
50	1 1/4	16	727 926 352	-	0.281	54	93	127	30	99	
50	1 1/2	16	727 926 310	-	0.283	54	93	126	30	99	
50	2	16	727 926 351	-	0.291	54	93	132	30	99	
63	1 1/2	16	727 926 358	-	0.563	65	117	154	41	119	
63	2	16	727 926 311	-	0.568	65	117	156	41	119	
63	2 1/2	16	727 926 357	-	0.579	65	117	160	41	119	
75	2	16	727 926 364	-	0.820	77	134	177	56	138	
75	2 1/2	16	727 926 312	-	0.823	77	134	178	56	134	
75	3	16	727 926 363	-	0.848	77	134	178	56	136	
90	2	16	727 926 371	-	1.390	93	160	205	68	168	
90	2 1/2	16	727 926 372	-	1.398	93	160	210	68	168	
90	3	16	727 926 313	-	1.414	93	160	210	68	168	
90	4	16	727 926 369	-	1.474	93	160	216	68	168	
110	3	16	727 926 376	-	1.865	113	181	226	71	178	
110	4	16	727 926 314	-	1.908	113	181	231	71	178	

PF 2 85 511 000

27 70 63

Flanged joint with metal flange

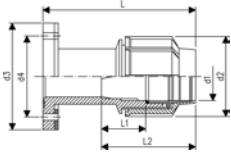

- active sealing system (with thrust ring); d16-63 double lip gasket; d75-110 spring gasket
- suitable for PE and PEX-a pipes
- installation without disassembling
- water PN16
- material: PP
- gasket: NBR quality for drinkable water
- flange: steel
- colour: blue-black

d	DN	DN	PN	Code	GP	kg	d1	d2	d3	d4	L	L1	L2
[mm]	[inch]	[mm]					[mm]	[mm]	[mm]	[mm]	[mm]	[mm]	[mm]
50	1 ½	40	16	727 706 350	-	1.291	54	93	150	110	170	36	100
50	2	50	16	727 706 351	-	1.241	54	93	174	125	170	36	100
63	2	50	16	727 706 311	-	1.527	65	117	174	125	193	48	126
63	2 ½	65	16	727 706 357	-	1.823	65	117	185	145	195	48	127
75	2 ½	65	16	727 706 312	-	1.945	78	134	185	145	197	104	185
75	3	80	16	727 706 363	-	2.138	78	134	200	160	197	82	162
90	3	80	16	727 706 313	-	2.744	93	160	200	160	232	65	166
90	4	100	16	727 706 369	-	2.959	93	160	220	181	232	65	166
110	4	100	16	727 706 314	-	3.343	113	181	220	181	239	107	220

PF 2 85 511 120

27 91 63

Female adaptor

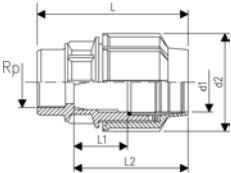

- (*) with stainless steel reinforcement ring **AISI430**
- active sealing system (with thrust ring); d16-63 double lip gasket; d75-110 spring gasket
- installation without disassembling
- suitable for PE and PEX-a pipes
- water PN16
- material: PP
- gasket: NBR quality for drinkable water
- female thread: ISO 7 (parallel)
- colour: blue-black

d	Rp	PN	Code	GP	kg	d1	d2	L	L1	L2
[mm]	[inch]					[mm]	[mm]	[mm]	[mm]	[mm]
16	½	16	727 916 329	325	0.046	22	46	78	15	54
16	¾	16	727 916 330	300	0.052	22	46	78	13	52
20	½	16	727 916 306	325	0.044	22	46	78	17	58
20	¾	16	727 916 333	300	0.050	22	46	78	16	57
25	½	16	727 916 337	175	0.074	28	57	86	18	61
25	¾	16	727 916 307	175	0.078	28	57	86	18	61
25	1	16	727 916 336	150	0.082	28	57	86	18	61
32	¾	16	727 916 341	125	0.112	34	67	95	20	67
32	1	16	727 916 308	125	0.115	34	67	95	20	67
*32	1 ¼	16	727 916 340	125	0.142	34	67	96	20	67
40	1	16	727 916 346	-	0.212	44	82	111	28	87
*40	1 ¼	16	727 916 309	-	0.241	44	82	116	28	87
*40	1 ½	16	727 916 345	-	0.254	44	82	116	28	87
*50	1	16	727 916 353	-	0.283	54	93	123	30	99
*50	1 ¼	16	727 916 352	-	0.314	54	93	129	30	99
*50	1 ½	16	727 916 310	-	0.324	54	93	128	30	99
*50	2	16	727 916 351	-	0.365	54	93	133	30	99
*63	1 ½	16	727 916 358	-	0.610	65	117	158	51	128
*63	2	16	727 916 311	-	0.656	65	117	161	51	128
*63	2 ½	16	158 001 728	-	0.665	65	117	162	46	122
*75	2	16	727 916 364	-	0.891	78	134	169	56	136
*75	2 ½	16	727 916 312	-	0.898	78	134	174	56	136
*75	3	10	158 001 729	-	0.901	78	134	174	56	136
*90	2	16	727 916 371	-	1.474	93	160	196	55	155
*90	2 ½	16	727 916 372	-	1.478	93	160	210	55	155
*90	3	10	727 916 313	-	1.488	93	160	196	55	155
*110	3	10	727 916 376	-	1.923	113	181	215	48	170
*110	4	10	727 916 314	-	1.987	113	181	215	48	170

PF 2 85 511 000

27 90 63

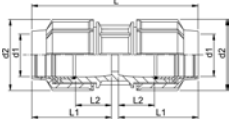

Coupling

- active sealing system (with thrust ring); d16-63 double lip gasket; d75-110 spring gasket
- installation without disassembling
- suitable for PE and PEX-a pipes
- water PN16
- gasket: NBR quality for drinkable water
- material: PP
- colour: blue-black

d [mm]	PN	Code	GP	kg	d1 [mm]	d2 [mm]	L [mm]	L1 [mm]	L2 [mm]
16	16	727 906 305	175	0.081	22	46	114	55	14
20	16	727 906 306	175	0.076	22	46	114	55	14
25	16	727 906 307	100	0.122	28	57	124	62	17
32	16	727 906 308	50	0.183	34	67	136	65	18
40	16	727 906 309	-	0.374	44	80	176	86	27
50	16	727 906 310	-	0.496	54	93	195	96	27
63	16	727 906 311	-	1.007	65	115	248	122	42
75	16	727 906 312	-	1.506	78	134	278	136	54
90	16	727 906 313	-	2.555	93	164	336	167	61
110	16	727 906 314	-	3.505	113	186	381	190	71

PF 2 85 511 000

27 93 63

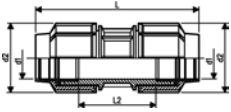

Repairing coupling (without pipe stop)

- non-compliance with kits and metal grip ring
- active sealing system (with thrust ring); d20-32 O-ring gasket; d40-63 oval gasket; d75-110 spring gasket
- installation without disassembling
- suitable for PE and PEX-a pipes
- water PN16
- material: PP
- gasket: NBR quality for drinkable water
- colour: blue-black

d [mm]	PN	Code	GP	kg	d1 [mm]	d2 [mm]	L [mm]	L2 [mm]
20	16	727 936 306	175	0.075	22	46	114	34
25	16	727 936 307	100	0.124	28	57	126	43
32	16	727 936 308	50	0.184	35	67	131	39
40	16	727 936 309	-	0.379	44	82	188	68
50	16	727 936 310	-	0.507	53	93	207	70
63	16	727 936 311	-	0.997	65	117	248	86
75	16	727 936 312	-	1.506	78	134	290	110
90	16	727 936 313	-	2.546	93	160	322	128
110	16	727 936 314	-	3.497	113	181	362	148

PF 2 85 511 000

27 90 63

Reducing coupling

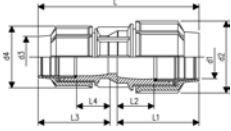

- active sealing system (with thrust ring); d16-63 double lip gasket; d75-110 spring gasket
- installation without disassembling
- suitable for PE and PEX-a pipes
- water PN16
- material: PP
- gasket: NBR quality for drinkable water
- colour: blue-black

d-d [mm]	PN	Code	GP	kg	d1 [mm]	d2 [mm]	d3 [mm]	d4 [mm]	L [mm]	L1 [mm]	L2 [mm]	L3 [mm]	L4 [mm]
20 - 16	16	727 906 334	175	0.073	22	46	22	46	116	56	15	56	17
25 - 16	16	727 906 335	125	0.095	28	54	22	46	133	63	21	56	17
25 - 20	16	727 906 337	125	0.110	28	54	22	46	133	63	21	56	15
32 - 20	16	727 906 340	75	0.127	35	64	22	46	130	65	18	56	15
32 - 25	16	727 906 341	75	0.166	35	64	28	54	130	65	18	59	18
40 - 25	16	727 906 347	-	0.279	44	82	28	54	160	94	34	63	21
40 - 32	16	727 906 346	-	0.291	44	82	35	64	164	94	34	66	22
50 - 32	16	727 906 353	-	0.328	53	93	35	64	175	103	34	69	25
50 - 40	16	727 906 352	-	0.468	53	93	44	82	204	103	34	97	38
63 - 32	16	727 906 356	-	0.626	65	115	34	64	210	118	38	80	34
63 - 40	16	727 906 357	-	0.582	65	117	44	82	216	117	38	87	30
63 - 50	16	727 906 358	-	0.756	65	117	53	93	216	117	38	96	28
75 - 50	16	727 906 363	-	1.008	78	134	53	93	237	129	48	100	32
75 - 63	16	727 906 364	-	1.229	78	134	65	117	249	129	48	116	37
90 - 63	16	727 906 371	-	1.799	93	160	65	117	292	169	61	107	36
90 - 75	16	727 906 370	-	2.018	93	160	78	134	366	188	87	175	94
110 - 90	16	727 906 376	-	3.011	113	181	93	160	363	188	70	168	61

PF 2 85 511 000

27 20 63

90° Tee

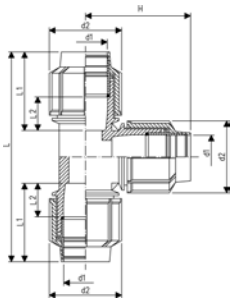

- active sealing system (with thrust ring); d16-63 double lip gasket; d75-110 spring gasket
- installation without disassembling
- suitable for PE and PEX-a pipes
- water PN16
- material: PP
- gasket: NBR quality for drinkable water
- colour: blue-black

d [mm]	PN	Code	GP	kg	d1 [mm]	d2 [mm]	L [mm]	L1 [mm]	L2 [mm]	H [mm]
16	16	727 206 305	100	0.127	22	46	138	57	13	55
20	16	727 206 306	100	0.121	22	46	138	55	13	55
25	16	727 206 307	50	0.196	28	57	153	60	18	77
32	16	727 206 308	30	0.297	34	67	175	66	20	87
40	16	727 206 309	-	0.609	44	82	238	88	27	118
50	16	727 206 310	-	0.821	53	93	259	96	28	128
63	16	727 206 311	-	1.658	65	117	317	113	35	160
75	16	727 206 312	-	2.400	78	134	360	129	48	180
90	16	727 206 313	-	4.216	93	160	472	183	82	140
110	16	727 206 314	-	5.588	113	181	512	193	80	260

PF 2 85 511 050

27 21 63

90° Tee with threaded female offtake

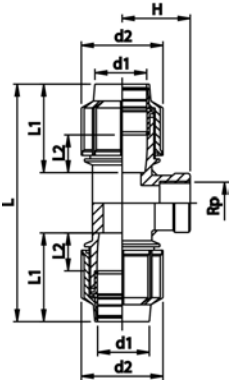

- (*) with stainless steel reinforcement ring **AISI430**
- active sealing system (with thrust ring); d16-63 double lip gasket; d75-110 spring gasket
- installation without disassembling
- suitable for PE and PEX-a pipes
- water PN16
- material: PP
- gasket: NBR quality for drinkable water
- female thread: ISO 7 (parallel)
- colour: blue-black

d	Rp	PN	Code	GP	kg	d1	d2	L	L1	L2	H
[mm]	[inch]					[mm]	[mm]	[mm]	[mm]	[mm]	[mm]
16	½	16	727 216 329	125	0.094	22	46	142	57	18	48
16	¾	16	727 216 330	125	0.099	22	46	142	58	19	53
20	½	16	727 216 306	125	0.090	22	46	143	58	18	48
20	¾	16	727 216 333	125	0.094	22	46	143	58	18	53
25	½	16	727 216 337	75	0.150	28	57	153	59	17	52
25	¾	16	727 216 307	75	0.146	28	57	153	60	18	37
25	1	16	727 216 336	75	0.153	28	57	153	59	17	59
32	½	16	727 216 342	45	0.233	34	67	175	66	20	41
32	¾	16	727 216 341	45	0.223	34	67	175	66	20	41
32	1	16	727 216 308	45	0.229	34	67	175	66	20	43
*32	1 ¼	16	727 216 340	45	0.258	34	67	175	66	20	46
40	¾	16	727 216 347	-	0.473	44	82	238	87	27	53
40	1	16	727 216 346	-	0.464	44	82	238	87	27	53
*40	1 ¼	16	727 216 309	-	0.474	44	82	238	87	27	53
*40	1 ½	16	727 216 345	-	0.486	44	82	238	83	24	53
*50	1	16	727 216 353	-	0.612	53	93	260	97	28	63
*50	1 ¼	16	727 216 352	-	0.666	53	93	260	97	28	63
*50	1 ½	16	727 216 310	-	0.653	53	93	260	97	28	63
*50	2	16	727 216 351	-	0.720	53	93	260	97	28	75
*63	1 ¼	16	727 216 359	-	1.219	65	117	317	113	35	70
*63	1 ½	16	727 216 358	-	1.207	65	117	317	113	35	70
*63	2	16	727 216 311	-	1.267	65	117	317	113	35	70
*75	2	10	158 001 730	-	1.828	78	134	360	129	48	75
*75	2 ½	16	727 216 312	-	1.808	78	134	360	129	48	75
*75	3	10	158 001 731	-	1.868	78	134	360	129	48	75
*90	3	10	727 216 313	-	3.136	93	160	472	183	82	101
*110	4	10	727 216 314	-	4.173	113	181	512	193	80	115

PF 2 85 511 080

27 20 63

90° Reducing-increasing Tee

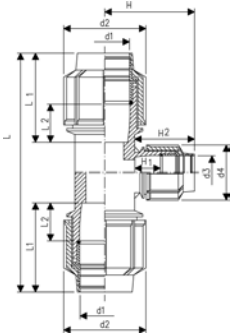

- active sealing system (with thrust ring); d16-63 double lip gasket; d75-110 spring gasket
- installation without disassembling
- suitable for PE and PEX-a pipes
- water PN16
- material: PP
- gasket: NBR quality for drinkable water
- colour: blue-black

d-d-d [mm]	PN	Code	GP	kg
20 - 16 - 20	16	727 206 334	100	0.118
20 - 25 - 20	16	727 206 335	75	0.140
25 - 20 - 25	16	727 206 337	50	0.172
25 - 32 - 25	16	727 206 338	30	0.220
32 - 25 - 32	16	727 206 341	30	0.270
40 - 32 - 40	16	727 206 346	-	0.530
50 - 32 - 50	16	727 206 353	-	0.709
50 - 40 - 50	16	727 206 352	-	0.776
63 - 32 - 63	16	727 206 357	-	1.233
63 - 50 - 63	16	727 206 358	-	1.369
75 - 63 - 75	16	727 206 364	-	2.147
90 - 75 - 90	16	727 206 366	-	3.919
110 - 90 - 110	16	727 206 367	-	5.344

d-d-d [mm]	d1 [mm]	d2 [mm]	d3 [mm]	d4 [mm]	L [mm]	L1 [mm]	L2 [mm]	H1 [mm]	H2 [mm]
20 - 16 - 20	22	46	22	46	143	58	18	18	57
20 - 25 - 20	22	46	28	54	144	58	18	17	59
25 - 20 - 25	28	54	22	46	153	58	17	18	58
25 - 32 - 25	28	54	35	64	155	59	17	19	65
32 - 25 - 32	35	64	28	54	173	64	19	21	63
40 - 32 - 40	44	82	35	64	238	87	27	21	66
50 - 32 - 50	53	93	35	64	259	96	28	21	68
50 - 40 - 50	53	93	44	82	259	96	28	38	94
63 - 32 - 63	65	117	35	64	317	113	35	19	65
63 - 50 - 63	65	117	53	93	317	113	35	28	90
75 - 63 - 75	78	134	65	117	360	129	48	35	113
90 - 75 - 90	93	160	78	134	472	183	48	63	150
110 - 90 - 110	113	181	93	160	512	193	68	82	180

PF 2 85 511 050

27 10 63

90° Elbow

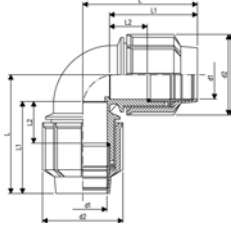

- active sealing system (with thrust ring); d16-63 double lip gasket; d75-110 spring gasket
- installation without disassembling
- suitable for PE and PEX-a pipes
- water PN16
- material: PP
- gasket: NBR quality for drinkable water
- colour: blue-black

d [mm]	PN	Code	GP	kg	d1 [mm]	d2 [mm]	L [mm]	L1 [mm]	L2 [mm]
16	16	727 106 305	150	0.084	22	46	71	58	18
20	16	727 106 306	150	0.078	22	46	71	58	18
25	16	727 106 307	100	0.125	28	57	77	60	17
32	16	727 106 308	50	0.192	34	67	88	67	20
40	16	727 106 309	-	0.410	44	82	117	86	27
50	16	727 106 310	-	0.551	53	93	128	97	28
63	16	727 106 311	-	1.108	65	117	160	114	35
75	16	727 106 312	-	1.633	78	134	178	129	48
90	16	727 106 313	-	2.915	93	160	235	163	62
110	16	727 106 314	-	3.879	113	181	250	168	57

PF 2 85 511 000

Metal wall-plate elbow

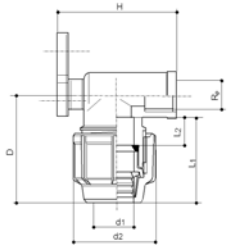

- active sealing system (with thrust ring); double lip gasket;
- suitable for PE and PEX-a pipes
- water PN16
- female thread: ISO 7 (parallel)
- material: Brass
- gasket: NBR quality for drinkable water

d [mm]	Rp [inch]	PN	Code	GP	kg	d1 [mm]	d2 [mm]	L [mm]	L1 [mm]	L2 [mm]	H [mm]
20	1/2	16	720 100 206	60	0.237	22	46	65	53	12	55
25	3/4	16	720 100 207	30	0.412	28	57	72	57	15	64

PF 2 85 511 000

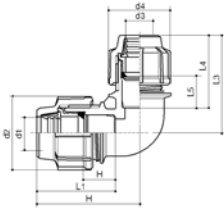

90° Reducing elbow

- active sealing system (with thrust ring); double lip gasket;
- installation without disassembling
- suitable for PE and PEX-a pipes
- water PN16
- material: PP
- gasket: NBR quality for drinkable water
- colour: blue-black

d-d [mm]	PN	Code	GP	kg
20 - 16	16	158 050 442	150	0.081
25 - 20	16	158 050 443	100	0.108

d-d [mm]	PN	d1 [mm]	d2 [mm]	d3 [mm]	d4 [mm]	L [mm]	L1 [mm]	L2 [mm]	L3 [mm]	L4 [mm]	L5 [mm]
20 - 16	16	22	46	22	46	77	58	18	71	58	18
25 - 20	16	27	54	22	46	80	65	21	77	58	18

PF 2 85 511 000

27 11 63

90° Elbow with threaded female offtake

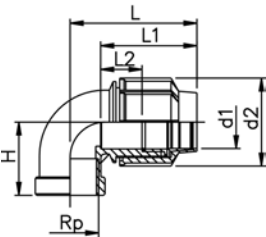

- (*) with stainless steel reinforcement ring **AISI430**
- active sealing system (with thrust ring); d16-63 double lip gasket; d75-110 spring gasket
- installation without disassembling
- suitable for PE and PEX-a pipes
- water PN16
- material: PP
- gasket: NBR quality for drinkable water
- female thread: ISO 7 (parallel)
- colour: blue-black

d [mm]	Rp [inch]	PN	Code	GP	kg	d1 [mm]	d2 [mm]	L [mm]	L1 [mm]	L2 [mm]	H [mm]
16	½	16	727 116 329	200	0.061	22	46	71	58	18	50
16	¾	16	727 116 330	200	0.063	22	46	71	58	18	50
20	½	16	727 116 306	200	0.058	22	46	71	58	18	50
20	¾	16	727 116 333	200	0.061	22	46	71	58	18	50
25	½	16	727 116 337	150	0.097	28	57	76	60	18	53
25	¾	16	727 116 307	150	0.090	28	57	77	60	18	53
25	1	16	727 116 336	125	0.095	28	57	77	60	18	60
32	½	16	727 116 342	100	0.160	34	67	87	68	22	60
32	¾	16	727 116 341	100	0.152	34	67	87	68	22	60
32	1	16	727 116 308	100	0.139	34	67	87	68	22	60
*32	1 ¼	16	727 116 340	75	0.159	34	67	87	68	22	47
40	¾	16	727 116 347	-	0.276	44	82	120	87	27	53
40	1	16	727 116 346	-	0.264	44	82	120	87	27	53
*40	1 ¼	16	727 116 309	-	0.272	44	82	120	87	27	53
*40	1 ½	16	727 116 345	-	0.290	44	82	120	83	23	53
*50	1	16	727 116 318	-	0.347	53	93	130	97	28	62
*50	1 ¼	16	727 116 319	-	0.406	53	93	130	97	28	62
*50	1 ½	16	727 116 310	-	0.385	53	93	130	97	28	62
*50	2	16	727 116 351	-	0.453	53	93	130	97	28	75
*63	1 ¼	16	727 116 321	-	0.733	65	117	160	114	35	70
*63	1 ½	16	727 116 320	-	0.718	65	117	160	114	35	70
*63	2	16	727 116 311	-	0.773	65	117	160	114	35	70
*63	2 ½	16	158 001 727	-	0.773	65	117	160	114	35	70
*75	2	16	158 001 732	-	1.021	78	134	178	129	48	75
*75	2 ½	16	727 116 312	-	1.046	78	134	178	129	48	75
*75	3	10	158 001 733	-	1.077	78	134	178	129	48	75
*90	3	10	727 116 313	-	1.804	93	160	235	163	62	100
*110	4	10	727 116 314	-	2.435	113	181	250	168	57	116

PF 2 85 511 000

27 22 63

90° Tee with threaded male offtake

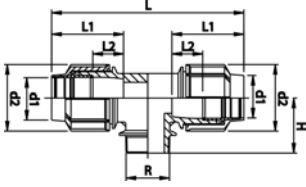

- active sealing system (with thrust ring); d16-63 double lip gasket; d75-110 spring gasket
- installation without disassembling
- suitable for PE and PEX-a pipes
- water PN16
- material: PP
- gasket: NBR quality for drinkable water
- male thread: ISO 7 (conical)
- colour: blue-black

d	R	PN	Code	GP	kg	d1	d2	L	L1	L2	H
[mm]	[inch]					[mm]	[mm]	[mm]	[mm]	[mm]	[mm]
16	1/2	16	727 226 329	125	0.097	22	46	142	58	19	50
16	3/4	16	727 226 330	125	0.097	22	46	142	58	19	50
20	1/2	16	727 226 306	125	0.087	22	46	143	58	18	50
20	3/4	16	727 226 333	125	0.093	22	46	143	58	18	50
25	1/2	16	727 226 337	75	0.144	28	54	153	58	17	52
25	3/4	16	727 226 307	75	0.144	28	54	153	58	17	54
25	1	16	727 226 336	75	0.150	28	54	153	58	17	52
32	3/4	16	727 226 341	45	0.221	34	67	175	66	20	60
32	1	16	727 226 308	45	0.221	34	67	175	66	20	60
40	3/4	16	727 226 347	-	0.444	44	82	238	88	27	82
40	1 1/4	16	727 226 309	-	0.466	44	82	238	88	27	73
40	1 1/2	16	727 226 349	-	0.460	44	82	238	88	27	73
50	3/4	16	727 226 354	-	0.603	53	93	259	96	28	86
50	1 1/4	16	727 226 355	-	0.647	53	93	259	96	28	80
50	1 1/2	16	727 226 310	-	0.639	53	93	259	96	28	80
63	1 1/4	16	727 226 357	-	1.169	65	117	317	113	35	80
63	1 1/2	16	727 226 358	-	1.185	65	117	317	113	35	80
63	2	16	727 226 311	-	1.170	65	117	317	113	35	82
63	2 1/2	16	727 226 359	-	1.195	65	117	317	113	35	85
75	2 1/2	16	727 226 361	-	1.790	78	134	360	129	48	105
75	3	16	158 001 000	-	1.807	78	134	360	129	48	105
90	3	16	158 001 001	-	3.283	93	160	472	183	82	132
110	4	16	158 001 002	-	4.309	113	181	512	193	80	145

PF 2 85 511 070

27 12 63

90° Elbow with threaded male offtake

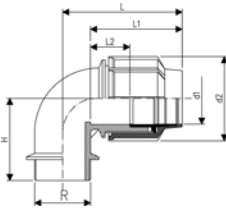

- active sealing system (with thrust ring); d16-63 double lip gasket; d75-110 spring gasket
- installation without disassembling
- suitable for PE and PEX-a pipes
- water PN16
- material: PP
- gasket: NBR quality for drinkable water
- male thread: ISO 7 (conical)
- colour: blue-black

d	R	PN	Code	GP	kg	d1	d2	L	L1	L2	H
[mm]	[inch]					[mm]	[mm]	[mm]	[mm]	[mm]	[mm]
16	1/2	16	727 126 329	200	0.056	22	46	71	58	18	50
16	3/4	16	727 126 330	200	0.056	22	46	71	58	19	50
20	1/2	16	727 126 306	200	0.052	22	46	71	58	18	50
20	3/4	16	727 126 333	200	0.053	22	46	71	58	18	50
25	1/2	16	727 126 337	150	0.086	28	57	77	63	21	53
25	3/4	16	727 126 307	150	0.086	28	57	77	60	17	53
25	1	16	727 126 336	150	0.080	28	57	77	60	17	53
32	1/2	16	727 126 338	100	0.127	34	67	88	68	22	60
32	3/4	16	727 126 339	100	0.126	34	67	88	68	22	60
32	1	16	727 126 308	100	0.133	34	67	88	68	22	60
40	1	16	727 126 344	-	0.270	44	82	115	83	23	75
40	1 1/4	16	727 126 309	-	0.268	44	82	117	86	27	73
40	1 1/2	16	727 126 345	-	0.260	44	82	117	86	27	73
50	1 1/4	16	727 126 352	-	0.383	53	93	128	97	28	78
50	1 1/2	16	727 126 310	-	0.379	53	93	128	97	28	80
63	1 1/4	16	727 126 313	-	0.653	65	117	160	114	35	82
63	1 1/2	16	727 126 312	-	0.659	65	117	160	114	35	82
63	2	16	727 126 311	-	0.715	65	117	160	114	35	82
63	2 1/2	16	727 126 314	-	0.681	65	117	160	114	35	82
75	2 1/2	16	727 126 316	-	1.041	77	134	178	129	48	110
75	3	16	727 126 317	-	1.051	77	134	178	129	48	110
90	3	16	727 126 515	-	1.050	93	160	240	170	62	132
90	4	16	158 001 692	-	1.864	93	160	245	165	48	135
110	3	16	158 001 710	-	2.323	113	181	245	175	66	142
110	4	16	158 001 003	-	2.606	113	185	256	180	60	140

PF 2 85 511 000

27 15 63

45° Elbow

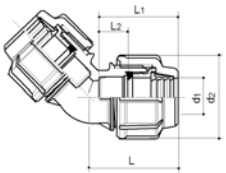

- active sealing system (with thrust ring); double lip gasket;
- installation without disassembling
- suitable for PE and PEX-a pipes
- water PN16
- material: PP
- gasket: NBR quality for drinkable water
- colour: blue-black

d	PN	Code	GP	kg	d1	d2	L	L1	L2
[mm]					[mm]	[mm]	[mm]	[mm]	[mm]
20	16	727 156 306	150	0.083	22	46	65	56	14
25	16	727 156 307	100	0.132	28	57	74	60	17
32	16	727 156 308	50	0.200	34	67	82	67	19
40	16	727 156 309	-	0.407	44	82	108	86	27
50	16	727 156 310	-	0.547	53	93	128	99	30
63	16	727 156 311	-	1.087	65	118	150	115	35

PF 2 85 511 000

27 16 63

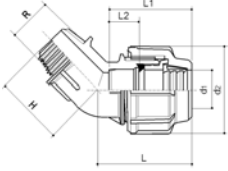

PF 2 85 511 000

45° Elbow with threaded male offtake

- active sealing system (with thrust ring); double lip gasket;
- installation without disassembling
- suitable for PE and PEX-a pipes
- water PN16
- material: PP
- gasket: NBR quality for drinkable water
- male thread: ISO 7 (conical)
- colour: blue-black

d [mm]	R [inch]	PN	Code	GP	kg	d1 [mm]	d2 [mm]	L [mm]	L1 [mm]	L2 [mm]	H [mm]
20	1/2	16	727 166 306	200	0.050	22	46	65	56	14	41
25	3/4	16	727 166 307	150	0.079	28	57	73	60	17	44
32	1	16	727 166 308	75	0.122	34	67	83	66	19	48
40	1 1/4	16	727 166 309	-	0.241	44	82	108	86	27	65
50	1 1/2	16	727 166 310	-	0.326	53	93	128	99	30	69
63	2	16	727 166 311	-	0.651	65	118	150	115	30	85

27 96 63

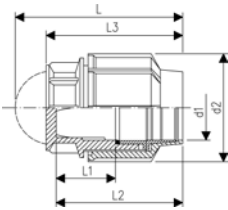

PF 2 85 511 000

End cap

- active sealing system (with thrust ring); d16-63 double lip gasket; d75-110 spring gasket
- installation without disassembling
- suitable for PE and PEX-a pipes
- water PN16
- material: PP
- gasket: NBR quality for drinkable water
- colour: blue-black

d [mm]	PN	Code	GP	kg	d1 [mm]	d2 [mm]	L [mm]	L1 [mm]	L2 [mm]	L3 [mm]
16	16	727 966 305	350	0.044	22	46	60	20	60	62
20	16	727 966 306	350	0.041	22	46	69	18	58	62
25	16	727 966 307	200	0.066	28	57	76	18	63	65
32	16	727 966 308	125	0.103	34	67	90	18	70	69
40	16	727 966 309	-	0.211	44	82	112	28	87	93
50	16	727 966 310	-	0.289	54	93	129	30	99	105
63	16	727 966 311	-	0.580	65	117	160	42	122	132
75	16	727 966 312	-	0.838	78	134	180	56	139	147
90	16	727 966 313	-	1.429	93	160	220	68	173	181
110	16	727 966 314	-	1.911	114	182	234	70	184	195

27 92 65

Male adaptor with threaded metal offtake (nickeked brass)

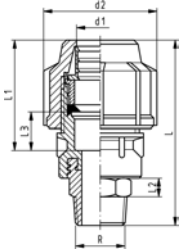

PF 2 85 511 010

- (*) without hexagon
- active sealing system (with thrust ring); double lip gasket;
- installation without disassembling
- suitable for PE and PEX-a pipes
- water PN16
- material: PP
- gasket: NBR quality for drinkable water
- male thread: ISO 7 (cilindric); Nickered brass
- colour: blue-black

d	R	PN	Code	L	L1	d2	L2	d1	L3
[mm]	[inch]			[mm]	[mm]	[mm]	[mm]	[mm]	[mm]

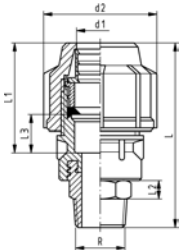

27 92 65

Male adaptor with threaded metal offtake (bronze)



PF 2 85 511 010

- (*) without hexagon
- active sealing system (with thrust ring); double lip gasket;
- installation without disassembling
- suitable for PE and PEX-a pipes
- water PN16
- material: PP
- gasket: NBR quality for drinkable water
- male thread: ISO 7 (cilindric); Bronze
- colour: blue-black

d	R	PN	Code	GP	kg	L	L1	d2	L2	d1	L3
[mm]	[inch]					[mm]	[mm]	[mm]	[mm]	[mm]	[mm]
*20	1/2	16	727 926 506	-	0.125	94	56	46		22	15
25	3/4	16	727 926 507	-	0.210	115	62	57	15	28	19
32	3/4	16	727 926 508	-	0.241	120	67	67	15	34	20
32	1	16	727 926 509	-	0.356	120	67	67	15	34	20
32	1 1/4	16	727 926 510	-	0.549	120	67	67	15	34	20
32	1 1/2	16	158 001 015	-	0.561	132	69	67	15	34	20
40	1	16	727 926 511	-	0.455	146	88	82	15	43	30
40	1 1/4	16	727 926 512	-	0.633	146	88	82	15	43	30
 40	1 1/2	16	727 926 516	-	0.689	150	88	82	15	43	30
 40	2	16	727 926 517	-	0.906	160	88	82	18	43	30
 50	1 1/4	16	727 926 513	-	0.684	161	99	93	15	53	28
50	1 1/2	16	727 926 514	-	0.749	162	99	93	15	53	30
63	1 1/2	16	158 001 016	-	0.975	185	124	118	15	65	42
63	2	16	727 926 515	-	1.217	190	118	118	18	65	42

27 91 65

Female adaptor with metal offtake (nickeled brass)

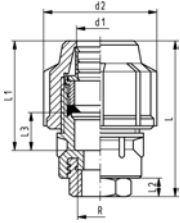

- (*) without hexagon
- active sealing system (with thrust ring); double lip gasket;
- installation without disassembling
- suitable for PE and PEX-a pipes
- water PN16
- material: PP
- gasket: NBR quality for drinkable water
- female thread: ISO 7 (parallel); Nickeled brass
- colour: blue-black

d	Rp	PN	Code	GP	kg	L	L1	d2	L2	d1	L3	
[mm]	[inch]					[mm]	[mm]	[mm]	[mm]	[mm]	[mm]	
20	1/2	16	158 001 578	-	0.101	80	57	46	0	22	15	
25	3/4	16	158 001 579	-	0.170	100	61	57	15	28	18	
32	1	16	158 001 580	-	0.289	105	67	67	15	34	20	
40	1 1/4	16	158 001 581	-	0.516	130	88	82	15	43	29	
50	1 1/2	16	158 001 582	-	0.628	140	98	93	15	53	30	
63	2	16	158 001 583	-	1.039	165	118	118	20	65	42	

PF 2 85 511 010

27 91 65

Female adaptor with metal offtake (bronze)

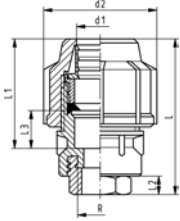

- (*) without hexagon
- active sealing system (with thrust ring); double lip gasket;
- installation without disassembling
- suitable for PE and PEX-a pipes
- water PN16
- material: PP
- gasket: NBR quality for drinkable water
- female thread: ISO 7 (parallel); Bronze
- colour: blue-black

d	Rp	PN	Code	GP	kg	L	L1	d2	L2	d1	L3	
[mm]	[inch]					[mm]	[mm]	[mm]	[mm]	[mm]	[mm]	
*20	1/2	16	727 916 506	-	0.105	80	57	46		22	15	
25	3/4	16	727 916 507	-	0.170	100	61	57	15	28	18	
32	1	16	727 916 509	-	0.298	105	67	67	15	34	20	
40	1 1/4	16	727 916 512	-	0.528	130	88	82	15	43	29	
50	1 1/2	16	727 916 513	-	0.647	140	98	93	15	53	30	
63	2	16	727 916 514	-	1.036	165	118	118	20	65	42	

PF 2 85 511 010

27 12 65

90° Male elbow with threaded metal offtake (nickeled brass)

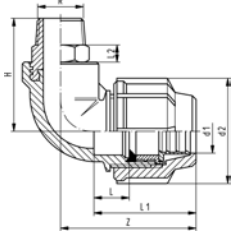

PF 2 85 511 010

- (*) without hexagon
- active sealing system (with thrust ring); double lip gasket;
- installation without disassembling
- suitable for PE and PEX-a pipes
- water PN16
- material: PP
- gasket: NBR quality for drinkable water
- male thread: ISO 7 (cilindric); Nickeled brass
- colour: blue-black

d [mm]	R [inch]	PN	Code	GP	kg	L1 [mm]	d2 [mm]	L2 [mm]	d1 [mm]	z [mm]	H [mm]	L [mm]
*20	1/2	16	158 001 584	-	0.126	55	46		22	65	45	15
25	3/4	16	158 001 585	-	0.218	60	57	15	28	75	60	18
32	3/4	16	158 001 586	-	0.255	70	67	15	34	92	70	23
32	1	16	158 001 587	-	0.358	70	67	15	34	100	70	25
40	1	16	158 001 588	-	0.457	86	82	15	43	123	71	28
40	1 1/4	16	158 001 589	-	0.650	86	82	15	43	123	80	28

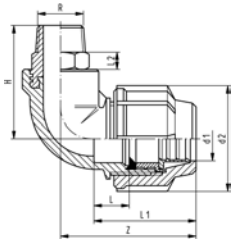

27 12 65

90° Male elbow with threaded metal offtake (bronze)



PF 2 85 511 010

- (*) without hexagon
- active sealing system (with thrust ring); double lip gasket;
- installation without disassembling
- suitable for PE and PEX-a pipes
- water PN16
- material: PP
- gasket: NBR quality for drinkable water
- male thread: ISO 7 (cilindric); Bronze
- colour: blue-black

d [mm]	R [inch]	PN	Code	GP	kg	L1 [mm]	d2 [mm]	L2 [mm]	d1 [mm]	z [mm]	H [mm]	L [mm]
*20	1/2	16	727 126 506	-	0.132	55	46		22	65	45	15
25	3/4	16	727 126 507	-	0.221	60	57	15	28	75	60	18
32	3/4	16	727 126 508	-	0.258	70	67	15	34	92	70	23
32	1	16	727 126 509	-	0.379	70	67	15	34	100	70	25
32	1 1/2	16	158 001 017	-	0.607	68	67	15	34	90	85	23
40	1	16	727 126 511	-	0.478	86	82	15	43	123	71	28
40	1 1/4	16	727 126 512	-	0.668	86	82	15	43	123	80	28
 40	1 1/2	16	727 126 510	-	0.734	86	82	15	43	123	71	28
 40	2	16	727 126 514	-	0.942	86	82	18	43	123	95	28
50	1 1/4	16	727 126 513	-	0.732	99	93	15	53	130	82	27
63	1 1/2	16	158 001 018	-	1.062	122	118	15	65	163	97	40

27 90 63

Blanking plug



- maximum operating pressure PN 16
- material: PP

d [mm]	PN	Code	GP	kg
20	16	158 050 437	300	0.007
25	16	158 050 438	250	0.009
32	16	158 050 439	180	0.015
40	16	158 050 440	80	0.036
50	16	158 050 441	60	0.054

PF 2 85 511 000

27 90 63

Metal tightening wrench for POLY16 Plus fittings

- (*)Polypropylene
- also sold as individual pieces

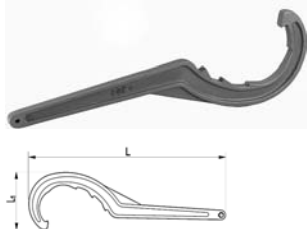

d-d [mm]	Code	GP	kg	L [mm]	L1 [mm]
*16 - 32	799 198 097	-	0.055	210	75
40 - 63	799 198 098	-	0.400	405	100
75 - 110	799 198 099	-	1.000	550	150

PF 2 85 511 000



POLY16 Plus Plastic Wall plate Elbow

d [mm]	Rp [inch]	PN	Code	Code	GP	kg	d1 [mm]	d2 [mm]	L [mm]	L1 [mm]	L2 [mm]	H [mm]
20	½	16	158 001 919	09202002P	250	0.053	22	45	62	16	51	52
25	¾	16	158 001 920	09202504P	120	0.098	28	56	80	16	63	66

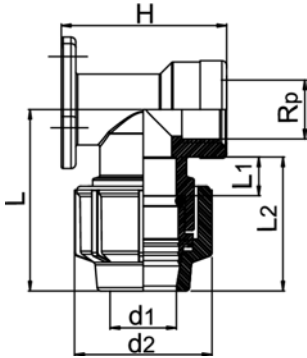

PF 2 85 511 000

POLY16 Plus KITS



Reducing set

- suitable for PE and PEX-a pipes
- maximum operating pressure PN 16
- material: PP
- gasket: NBR quality for drinkable water
- non-compliance with POLY16 Plus repairing coupling

d-d [mm]	PN	Code	GP	kg
25 - 20	16	727 826 430	10	0.021
32 - 20	16	727 826 431	10	0.040
32 - 25	16	727 826 432	10	0.032
40 - 20	16	727 826 433	8	0.070
40 - 25	16	727 826 434	8	0.075
40 - 32	16	727 826 435	8	0.065
50 - 25	16	727 826 436	6	0.101
50 - 32	16	727 826 437	6	0.112
50 - 40	16	727 826 438	6	0.104
63 - 25	16	727 826 439	5	0.178
63 - 32	16	727 826 440	5	0.195
63 - 40	16	727 826 441	5	0.195
63 - 50	16	727 826 442	5	0.192

PF 2 85 511 000



Grip ring in stainless steel for PVC-U and ABS pipes

- with PVC-U pipe: maximum operating pressure PN16
- with ABS pipe: maximum operating pressure PN10
- material: stainless steel AISI304
- non-compliance with POLY16 Plus repairing coupling

d [mm]	Code	GP	kg
20	727 826 415	25	0.001
25	727 826 416	25	0.003
32	727 826 417	25	0.004
40	727 826 418	25	0.006
50	727 826 419	25	0.010
63	727 826 420	25	0.025

PF 2 85 511 000



Kit for copper pipe DIN BS EN 1057 pull out resistance

- maximum operating pressure PN 16
- gasket: NBR; grip ring in stainless steel (AISI304); PP
- non-compliance with POLY16 Plus repairing coupling

d fitting [mm]	d copper pipe [mm]	PN	Code	GP	kg
20	15	16	727 826 400	15	0.016
25	22	16	727 826 401	15	0.023
32	28	16	727 826 402	12	0.028

PF 2 85 511 000



Kit consisting of PVC-C Split ring and FPM (Viton) gasket

- suitable for PE and PEX-a pipes
- maximum operating pressure PN 16
- (*) with thrust ring
- non-compliance with POLY16 Plus repairing coupling

d [mm]	PN	Code	GP	kg
20	16	727 826 506	25	0.004
25	16	727 826 507	25	0.006
32	16	727 826 508	25	0.010
40	16	727 826 509	25	0.022
50	16	727 826 510	25	0.029
63	16	727 826 511	25	0.072
*75	10	727 826 512	25	0.088
*90	10	727 826 513	25	0.134
*110	10	727 826 514	25	0.194

PF 2 85 511 000

POLY16 Plus SPARE PARTS

Split ring



- also sold as individual pieces

d [mm]	Code	GP	kg
16	727 826 405	-	0.003
20	727 826 406	-	0.003
25	727 826 407	-	0.004
32	727 826 408	-	0.006
40	727 826 409	-	0.014
50	727 826 410	-	0.018
63	727 826 411	-	0.044
75	727 826 421	-	0.078
90	727 826 422	-	0.078
110	727 826 423	-	0.098

PF 2 85 511 000

Gasket



- also sold as individual pieces

d [mm]	Code	GP	kg
16	745 416 405	-	0.001
20	745 416 406	-	0.001
25	745 416 407	-	0.002
32	745 416 408	-	0.004
40	745 416 409	-	0.008
50	745 416 410	-	0.011
63	745 416 411	-	0.019
75	745 416 400	-	0.020
90	745 416 401	-	0.020
110	745 416 402	-	0.040

PF 2 85 511 000

Repairing coupling gasket

- also sold as individual pieces

d [mm]	Code	GP	kg
20	158 001 004	-	0.001
25	158 001 005	-	0.001
32	158 001 006	-	0.002
40	158 001 007	-	0.007
50	158 001 008	-	0.010
63	158 001 009	-	0.015

PF 2 85 511 000



Thrust ring

- also sold as individual pieces

d [mm]	Code	GP	kg
16	727 816 405	-	0.003
20	727 816 406	-	0.004
25	727 816 407	-	0.006
32	727 816 408	-	0.008
40	727 816 409	-	0.018
50	727 816 410	-	0.026
63	727 816 411	-	0.041
75	727 816 400	-	0.080
90	727 816 401	-	0.126
110	727 816 402	-	0.175

PF 2 85 511 000



Nut

- also sold as individual pieces

d [mm]	Code	GP	kg
16 - 20	727 696 406	-	0.018
25	727 696 407	-	0.029
32	727 696 408	-	0.046
40	727 696 409	-	0.089
50	727 696 410	-	0.111
63	727 696 411	-	0.228
75	727 696 412	-	0.363
90	727 696 413	-	0.614
110	727 696 414	-	0.840

PF 2 85 511 000

POLY16 Plus Plastic Stop Cock Valves

Plastic Stop Cock Valve



- suitable for PE
- water PN16
- non-compliance with kits
- material: PP
- gasket: O-ring (EPDM)

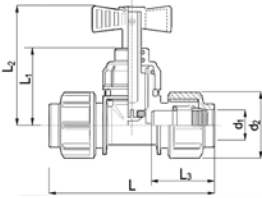

PF 2 85 511 000

d [mm]	PN	Code	GP	kg	d [mm]	L [mm]	L1 [mm]	L2 [mm]	L3 [mm]	d1 [mm]	d2 [mm]
20	16	158 001 872	20	0.190	20	128	64	93	50	20	47
25	16	158 001 874	20	0.221	25	138	65	93	53	25	54
32	16	158 001 876	12	0.334	32	158	71	98	60	32	65

POLY16 Plus Universal Fittings

Coupling

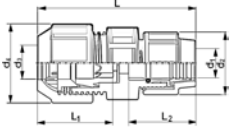

- black offtake: suitable for Metric and Imperial PE, PEX, PVC, ABS, galvanized, lead, copper pipes
- blue offtake: suitable for PE pipe
- water PN10
- material: PP
- gasket: EPDM quality for drinkable water
- non-compliance with POLY16 Plus kits
- colour: blue-black

PE outlet [mm]	Universal outlet [mm]	PN	Code	GP	kg
20	15 - 21	10	158 001 713	140	0.119
20	21 - 27	10	158 001 714	100	0.164
20	27 - 35	10	158 001 715	70	0.269
25	15 - 21	10	158 001 716	100	0.145
25	21 - 27	10	158 001 717	90	0.189
25	27 - 35	10	158 001 718	60	0.239
32	21 - 27	10	158 001 719	70	0.206
32	27 - 35	10	158 001 720	50	0.312

PE outlet [mm]	Universal outlet [mm]	PN	d1 [mm]	d2 [mm]	d3 [mm]	d4 [mm]	L [mm]	L1 [mm]	L2 [mm]
20	15 - 21	10	20	47	15 - 21	55	119	55	55
20	21 - 27	10	20	47	21 - 27	65	127	70	55
20	27 - 35	10	20	47	27 - 35	80	151	88	55
25	15 - 21	10	25	57	15 - 21	55	128	55	55
25	21 - 27	10	25	57	21 - 27	65	136	70	55
25	27 - 35	10	25	57	27 - 35	80	162	88	55
32	21 - 27	10	32	66	21 - 27	65	159	70	75
32	27 - 35	10	32	66	27 - 35	80	174	88	75

PF 2 85 511 000

90° Elbow

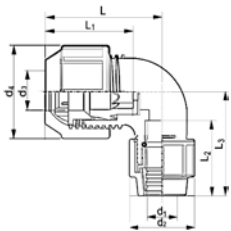

- black offtake: suitable for Metric and Imperial PE, PEX, PVC, ABS, galvanized, lead, copper pipes
- blue offtake: suitable for PE pipe
- water PN10
- material: PP
- gasket: EPDM quality for drinkable water
- non-compliance with POLY16 Plus kits
- colour: blue-black

PE outlet [mm]	Universal outlet [mm]	PN	Code	GP	kg
25	15 - 21	10	158 001 721	100	0.146
25	21 - 27	10	158 001 722	90	0.201

PE outlet [mm]	Universal outlet [mm]	PN	d1 [mm]	d2 [mm]	d3 [mm]	d4 [mm]	L [mm]	L1 [mm]	L2 [mm]	L3 [mm]
25	15 - 21	10	25	57	15 - 21	55	69	55	65	74
25	21 - 27	10	25	57	21 - 27	65	76	70	70	74

PF 2 85 511 000



Universal Kit (in compliance with Universal fitting only)

- non-compliance with POLY16 fittings
- water PN10
- material: PP
- gasket: EPDM quality for drinkable water
- (*)Spare part

PE outlet [mm]	Universal outlet [mm]	PN	Code	GP	kg	
25	15 - 21	10	158 001 723	200	0.056	
32	21 - 27	10	158 001 724	150	0.081	
*	27 - 35	10	158 001 725	80	0.138	

PF 2 85 511 000

Tapping Saddles POLY16 Plus PE LINE Assembly Instructions

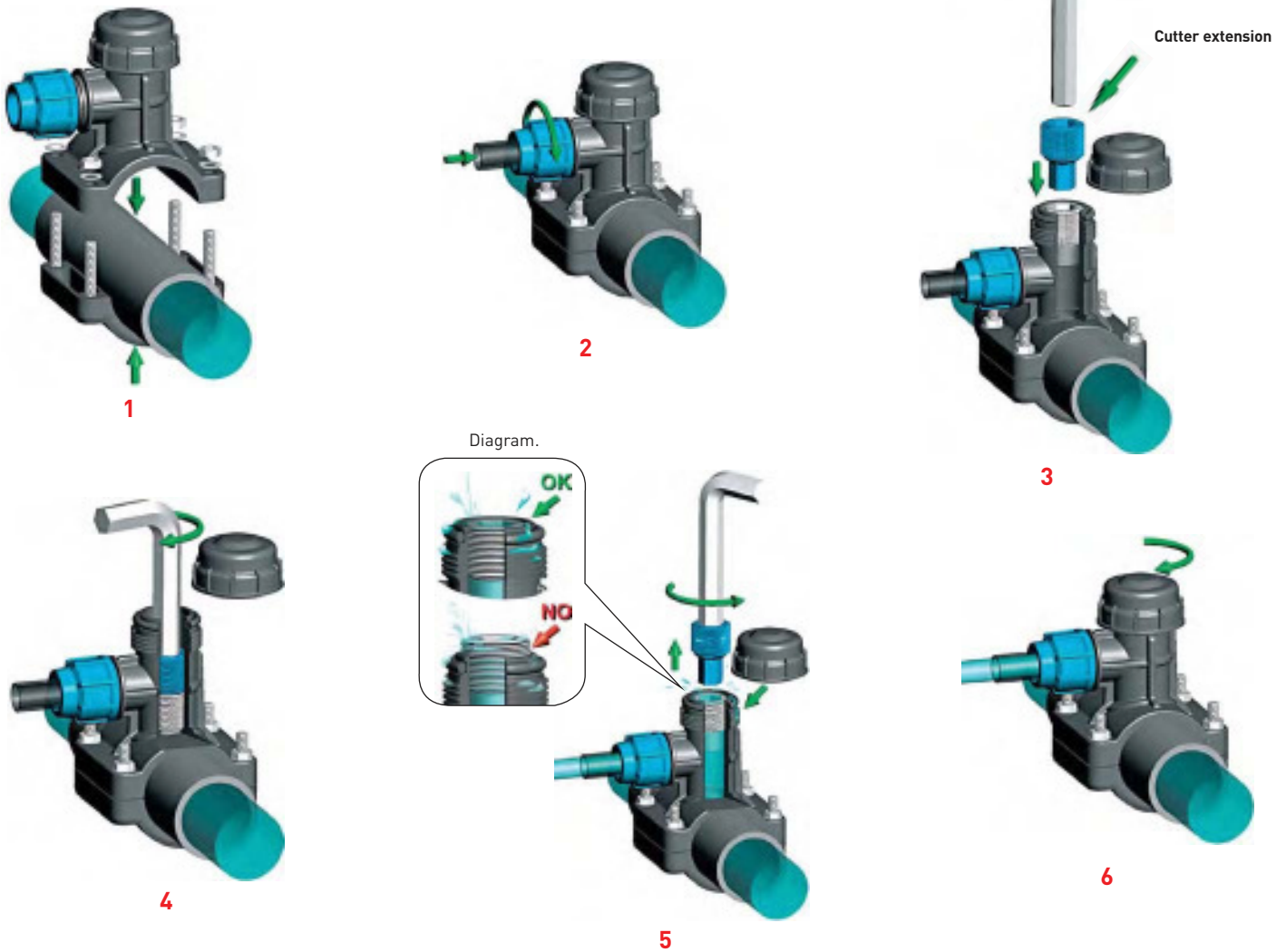

- 1 Place the bolts in the lower section of the saddle and place underneath the pipe. Assemble the gasket in the upper section site. Attach the upper section and tighten diagonally. *(If SS bolts are used, lubrication of the bolts is recommended).*
- 2 Insert the outlet pipe (or connect the female thread) and assemble in accordance with the compression fittings instructions.
- 3 Unscrew the sealing cap and insert the relevant threaded extension into the hexagonal recess of the cutter. Screw using an hexagonal standard key (Tab.1). *Caution: take care to align hexagons threaded extension-cutter, and saddle-extension threads.*
- 4 Screw the threaded extension/cutter system until a small amount of water will escape through the threads, and/or until the screwing strenght decreases, showing the main has been tapped. When the screwing strenght increases again, you have reached the final stop of the cutter inside the saddle. We recommend to mark the key with the correct drilling depth (H), (Tab. 1). Screw the cutter until the mark aligns with the top of the saddle.
- 5 Unscrew the extension/cutter system to the top of the saddle: the cutter doesn't have to go beyond this point (see diagram in picture 5). Remove the threaded cutter extension.
- 6 To complete the assembly, refit the sealing cap using a tightening wrench for compression fittings.

Tab.1: 17 mm standard hexagonal key

	DN	H (mm)
<p>H = Drilling depth</p>	50-63	55
	75-90	65
	110-125-140-160 (25-32-40-1")	85
	110-125-140-160 (50-63-75-2")	95

Max. cut height (mm)

DN	mm
50	10
63	10
75	14
90	14
110	16
125	20
140	20
160	20

Tapping Saddle POLY16 Plus UNIVERSAL LINE Assembly Instructions

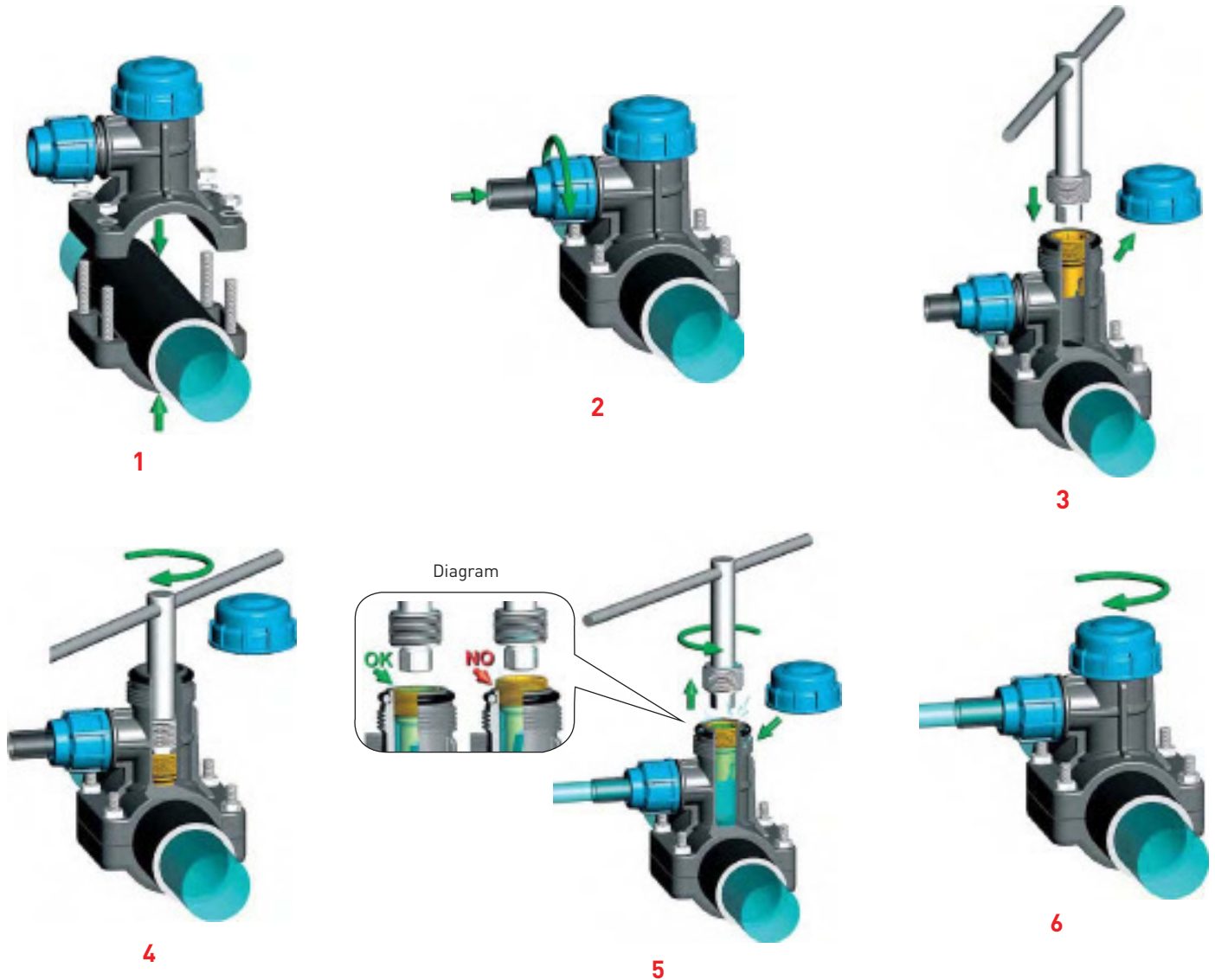

- 1** Place the bolts in the lower section of the saddle and place underneath the pipe. Assemble the gasket in the upper section site. Attach the upper section and tighten diagonally (*If SS bolts are used, lubrication of the bolts is recommended*).
- 2** Insert the outlet pipe (or connect the female thread) and assemble in accordance with the compression fittings instructions.
- 3** Unscrew the sealing cap and insert the special +GF+ key (Tab. 1) into the hexagonal recess of the cutter (*caution: take care to align the saddle and key threads*).
- 4** Screw the cutter into the pipe until a small amount of water will escape past the threads, and/or until the screwing strength decreases, showing the main has been tapped. When the screwing strength increases again, you have reached the final stop of the cutter inside the saddle. We recommend to mark the key (H) with the correct drilling depth (Tab.1). Screw the cutter until the mark aligns with the top of the tapping saddle thread.
- 5** Unscrew the cutter to the top of the tapping saddle thread: do not go beyond this point (see diagram in picture 5).
- 6** To complete the assembly, refit the sealing cap using the +GF+ spanner for compression fittings.

+GF+

Tab.1: Special +GF+ key

	DN	H (mm)
<p>H = Drilling depth</p>	50-63	80
	75-90	90
	110-125-140-160 (25-32-40-1")	110
	110-125-140-160 (50-63-75-2")	130

Max. cut height (mm)

DN	mm
50	10
63	10
75	14
90	14
110	16
125	20
140	20
160	20

POLY16 Plus CLAMP SADDLES

680C - Tapping Saddle for PE pipes with compression fitting offtake, O-ring gasket and galvanized bolts and nuts

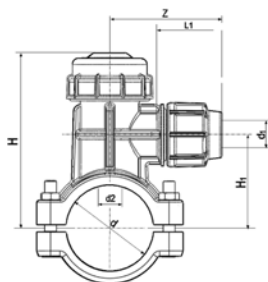

- water PN16
- suitable for PE and PEX-a pipes
- material: PP
- cutter: stainless steel (AISI304) and polyacetalic resin (POM)
- gasket: NBR (saddle and sealing cup: O-ring; offtake: double lip)
- bolts and nuts : galvanized
- colour: blue
- colour: blue-black
- B= N° of bolts
- M= bolt type

d	d1	PN	B	M	Code	GP	kg
[mm]	[mm]						
50	20	16	4	M8X50	700 627 715	10	0.385
50	25	16	4	M8x50	700 627 716	10	0.406
50	32	16	4	M8X50	700 627 717	10	0.434
63	20	16	4	M8X50	700 627 718	8	0.435
63	25	16	4	M8X50	700 627 719	8	0.456
63	32	16	4	M8X50	700 627 720	8	0.484
75	25	16	4	M8X70	700 627 721	6	0.595
75	32	16	4	M8X70	700 627 722	6	0.623
75	40	16	4	M8X70	700 627 723	5	0.725
90	25	16	4	M8X70	700 627 724	6	0.653
90	32	16	4	M8X70	700 627 725	5	0.681
90	40	16	4	M8X70	700 627 726	5	0.784
110	25	16	6	M8X70	700 627 727	2	0.937
110	32	16	6	M8X70	700 627 728	2	0.963
110	40	16	6	M8X70	700 627 729	2	1.062
110	50	16	6	M8X70	700 627 730	2	1.290
110	63	16	6	M8X70	700 627 731	1	1.563
110	75	16	6	M8X70	700 627 732	1	1.622
125	32	16	6	M8X70	700 627 733	2	1.313
125	40	16	6	M8X70	700 627 734	2	1.412
125	50	16	6	M8X70	700 627 735	2	1.499
125	63	16	6	M8X70	700 627 736	1	1.772
125	75	16	6	M8X70	700 627 737	1	2.042
140	32	16	6	M10X100	700 627 738	1	1.940
140	40	16	6	M10X100	700 627 739	1	2.038
140	50	16	6	M10X100	700 627 740	1	2.126
140	63	16	6	M10X100	700 627 741	1	2.399
140	75	16	6	M10X100	700 627 742	1	2.669
160	32	16	6	M10X110	700 627 743	1	1.990
160	40	16	6	M10X110	700 627 744	1	2.089
160	50	16	6	M10X110	700 627 745	1	2.176
160	63	16	6	M10X110	700 627 746	1	2.449
160	75	16	6	M10X110	700 627 747	1	2.719

d	d1	d2	H	H1	L	L1	z
[mm]	[mm]	[mm]	[mm]	[mm]	[mm]	[mm]	[mm]
50	20	26	118	58	75	55	80
50	25	26	118	58	75	58	90
50	32	26	118	58	75	64	100
63	20	26	125	65	90	55	80
63	25	26	125	65	90	60	90
63	32	26	125	65	90	63	100
75	25	33	142	75	98	60	90
75	32	33	142	75	98	62	100

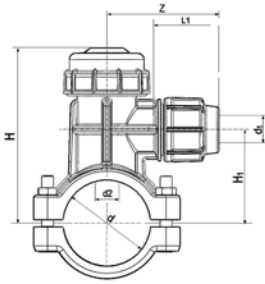

d	d1	d2	H	H1	L	L1	z
[mm]	[mm]	[mm]	[mm]	[mm]	[mm]	[mm]	[mm]
75	40	33	142	75	98	74	120
90	25	33	152	85	100	60	90
90	32	33	152	85	100	62	100
90	40	33	152	85	100	74	120
110	25	33	190	108	130	60	100
110	32	33	190	108	130	77	118
110	40	33	190	118	130	87	130
110	50	40	205	118	130	108	151
110	63	40	205	118	130	125	180
110	75	40	205	118	130	146	205
125	32	40	210	115	135	76	120
125	40	40	210	115	135	87	130
125	50	40	225	130	135	102	146
125	63	40	225	130	135	128	180
125	75	40	225	130	135	146	205
140	32	40	225	125	155	72	120
140	40	40	225	125	155	87	130
140	50	40	240	135	155	102	146
140	63	40	240	135	155	128	180
140	75	40	240	135	155	146	205
160	32	40	235	140	160	76	120
160	40	40	235	140	160	87	130
160	50	40	250	155	160	110	146
160	63	40	250	155	160	128	180
160	75	40	250	155	160	146	205

PF 2 85 788 001



680F - Tapping Saddle for PE pipes with threaded female offtake, O-ring gasket and galvanized bolts and nuts

- water PN16
- female thread: ISO 7 (parallel)
- suitable for PE and PEX-a pipes
- material: PP
- gasket: NBR (saddle and sealing cup: O-ring)
- bolts and nuts : galvanized
- colour: black
- B= N° of bolts
- M= bolt type

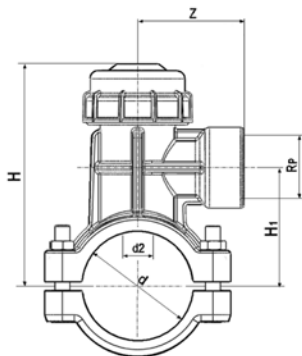

d	Rp	PN	B	M	Code	GP	kg	d2	H	H1	L	z
[mm]	[inch]							[mm]	[mm]	[mm]	[mm]	[mm]
50	1	16	4	M8x50	700 627 781	10	0.385	26	118	58	75	61
63	1	16	4	M8x50	700 627 782	8	0.435	26	125	65	90	61
75	1	16	4	M8x70	700 627 783	6	0.574	33	142	75	98	61
90	1	16	4	M8x70	700 627 784	5	0.632	33	152	85	100	61
90	2	16	4	M8x70	700 627 785	5	0.666	33	152	85	100	72
110	1	16	6	M8x70	700 627 786	2	0.917	33	190	108	130	78
110	2	16	6	M8x70	700 627 787	2	1.105	40	205	118	130	80
125	2	16	6	M8x70	700 627 788	-	1.313	40	225	130	135	80
140	2	16	6	M10X100	700 627 789	-	1.940	40	240	135	155	80
160	2	16	6	M10X110	700 627 790	-	1.990	40	250	155	160	80

PF 2 85 788 001



684C - Tapping Saddle for PE and PVC pipes with compression fitting offtake, flat gasket and stainless steel bolts and nuts

- water PN16
- suitable for PE, PEX-a and PVC pipes
- material: PP
- cutter: brass
- gasket: NBR (saddle: O-ring with flat lip; offtake: double lip; sealing cup: O-ring)
- bolts and nuts : stainless steel (bolts:AISI304-A2; nuts:AISI316-A4)
- colour: blue-black
- Key kit type (L=little; M=medium; B=big)
- B= N° of bolts
- M= bolt type

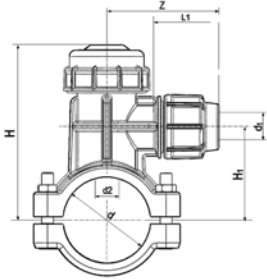

d	d1	PN	B	M	Key Kit type	Code	GP	kg
[mm]	[mm]							
50	20	16	4	M8X50	L	700 627 748	10	0.437
50	25	16	4	M8X50	L	700 627 749	10	0.458
50	32	16	4	M8X50	L	700 627 750	10	0.486
63	20	16	4	M8X50	L	700 627 751	8	0.487
63	25	16	4	M8X50	L	700 627 752	8	0.508
63	32	16	4	M8X50	L	700 627 753	8	0.536
75	25	16	4	M8X70	M	700 627 754	6	0.665
75	32	16	4	M8X70	M	700 627 755	6	0.693
75	40	16	4	M8X70	M	700 627 756	5	0.795
90	25	16	4	M8X70	M	700 627 757	6	0.723
90	32	16	4	M8X70	M	700 627 758	5	0.751
90	40	16	4	M8X70	M	700 627 759	5	0.853
110	25	16	6	M8X70	M	700 627 760	2	1.016
110	32	16	6	M8X70	M	700 627 761	2	1.042
110	40	16	6	M8X70	M	700 627 762	2	1.141
110	50	16	6	M8X70	B	700 627 763	2	1.490
110	63	16	6	M8X70	B	700 627 764	1	1.763
110	75	16	6	M8X70	B	700 627 765	1	1.821
125	32	16	6	M8X70	B	700 627 766	-	1.513
125	40	16	6	M8X70	B	700 627 767	-	1.611
125	50	16	6	M8X70	B	700 627 768	-	1.699
125	63	16	6	M8X70	B	700 627 769	-	1.972
125	75	16	6	M8X70	B	700 627 770	-	2.242
140	32	16	6	M10X100	B	700 627 771	-	2.164
140	40	16	6	M10X100	B	700 627 772	-	2.262
140	50	16	6	M10X100	B	700 627 773	-	2.349
140	63	16	6	M10X100	B	700 627 774	-	2.622
140	75	16	6	M10X100	B	700 627 775	-	2.893
160	32	16	6	M10X110	B	700 627 776	-	2.214
160	40	16	6	M10X110	B	700 627 777	-	2.312
160	50	16	6	M10X110	B	700 627 778	-	2.400
160	63	16	6	M10X110	B	700 627 779	-	2.673
160	75	16	6	M10X110	B	700 627 780	-	2.943

d	d1	d2	H	H1	L	L1	z
[mm]	[mm]	[mm]	[mm]	[mm]	[mm]	[mm]	[mm]
50	20	26	118	58	75	55	80
50	25	26	118	58	75	58	90
50	32	26	118	58	75	64	100
63	20	26	125	65	90	55	80
63	25	26	125	65	90	60	90
63	32	26	125	65	90	63	100
75	25	33	142	75	98	60	90
75	32	33	142	75	98	62	100
75	40	33	142	75	98	74	120
90	25	33	152	85	100	60	90
90	32	33	152	85	100	62	100
90	40	33	152	85	100	74	120

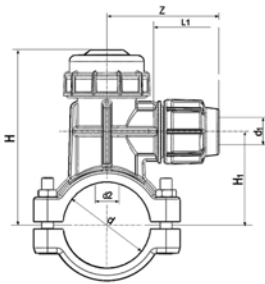

d	d1	d2	H	H1	L	L1	z
[mm]	[mm]	[mm]	[mm]	[mm]	[mm]	[mm]	[mm]
110	25	33	190	108	130	60	100
110	32	33	190	108	130	77	118
110	40	33	190	118	130	87	130
110	50	40	205	118	130	108	151
110	63	40	205	118	130	125	180
110	75	40	205	118	130	146	205
125	32	40	210	115	135	76	120
125	40	40	210	115	135	87	130
125	50	40	225	130	135	102	146
125	63	40	225	130	135	128	180
125	75	40	225	130	135	146	205
140	32	40	225	125	155	72	120
140	40	40	225	125	155	87	130
140	50	40	240	135	155	102	146
140	63	40	240	135	155	128	180
140	75	40	240	135	155	146	205
160	32	40	235	140	160	76	120
160	40	40	235	140	160	87	130
160	50	40	250	155	160	110	146
160	63	40	250	155	160	128	180
160	75	40	250	155	160	146	205

PF 2 85 788 003

684F - Tapping Saddle for PE and PVC pipes with threaded female offtake, flat gasket and stainless steel bolts and nuts



- water PN16
- female thread: ISO 7 (parallel)
- suitable for PE, PEX-a and PVC pipes
- material: PP
- cutter: brass
- gasket: NBR (saddle: O-ring with flat lip; sealing cup: O-ring)
- bolts and nuts : stainless steel (bolts:AISI304-A2; nuts:AISI316-A4)
- colour: blue
- colour: blue-black
- Key kit type (L=little; M=medium; B=big)
- B= N° of bolts
- M= bolt type

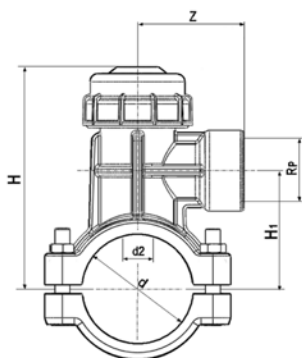

d	Rp	PN	B	M	Key Kit type	Code	GP	kg
[mm]	[inch]							
50	1	16	4	M8X50	L	700 627 791	10	0.437
63	1	16	4	M8X50	L	700 627 792	8	0.487
75	1	16	4	M8X70	M	700 627 793	6	0.644
90	1	16	4	M8X50	M	700 627 794	5	0.702
90	2	16	4	M8X50	M	700 627 795	5	0.736
110	1	16	6	M8X50	M	700 627 796	2	0.996
110	2	16	6	M8X50	B	700 627 797	2	1.304
125	2	16	6	M8X50	B	700 627 798	-	1.513
140	2	16	6	M10X100	B	700 627 799	-	2.164
160	2	16	6	M10X100	B	700 627 800	-	2.214

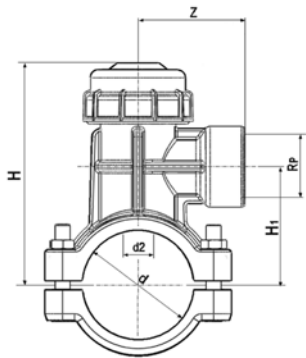

PF 2 85 788 003

d	Rp	d2	H	H1	L	z	
[mm]	[inch]	[mm]	[mm]	[mm]	[mm]	[mm]	
50	1	26	118	58	75	61	
63	1	26	125	65	90	61	
75	1	33	142	75	98	61	
90	1	33	152	85	100	61	
90	2	33	152	85	100	72	
110	1	33	190	108	130	78	
110	2	40	205	118	130	80	
125	2	40	225	130	135	80	
140	2	40	240	135	155	80	
160	2	40	250	155	160	80	



PF 2 85 788 003

Key kit for Tapping Saddle Universal Line

- Essential for Tapping Saddle Universal Line assembly

Dim.	Code	Code	GP	kg	
L (little)	158 001 777	99905100K	4	0.550	
M (medium)	158 001 778	99905101K	4	0.710	
B (big)	158 001 779	99905102K	4	0.910	

Clamp Saddles

Assembly instructions

- **PICTURE 1**: check that all components are present
- verify that on the surface of the pipe are not present impurities (dirt, sand, and so on) or tracks of lubricating oils which could cause sliding while assembling the saddle. **NO PICTURE**
- place the lower part of the saddle on the pipe in correspondence of the chosen area for the derivation. **PICTURE 2**
- position properly the gasket into its seat in the threaded part of the saddle **PICTURE 3**
- line up the threaded part with the lower part (already in position) and insert the screws from below, preferably in diagonal sequence so that one can simplify the lining up of the two parts. **PICTURE 4**
- insert the possible existing washers and screw the nuts without tightening in depth, until a first blocking of the saddle, so that the rotation on the pipe will be avoided (**). **PICTURE 5**
- punch the pipe in correspondence of the derivation area (*). **PICTURE 6**
- screw the threaded male of the fitting on the threaded female offtake of the saddle using a suitable quantity of teflon in order to fill the gap between the two threads **PICTURE 7**
- complete the screwing of the bolts until the two parts of the saddle touch each other (until size 8"; for bigger diameters, until a suitable draught of the bolt). **PICTURE 8**

Please, note: (*): The punching of the pipe can be advanced depending on the installer's experience.

(**): avoid to screw too much the bolts in course of this phase in order not to cause even if slight ovalizations of the threaded female offtake not assembled, yet that could cause subsequent difficulties in screwing the threaded male offtake.



PICTURE 1



PICTURE 2



PICTURE 3



PICTURE 4



PICTURE 5



PICTURE 6



PICTURE 7



PICTURE 8



654X - Blue clamp saddles with stainless steel reinforcement ring, flat gasket and stainless steel bolts and nuts (PN16-PN10)

- water PN16-10
- suitable for PE and PVC pipes
- material: PP
- female thread: ISO 7 (parallel)
- gasket: O-ring with flat lip (NBR)
- reinforcement ring: stainless steel AISI430
- bolts and nuts : stainless steel (bolts:AISI304-A2; nuts:AISI316-A4)
- colour: blue
- B= N° of bolts
- M= bolt type
- (*) with O-ring gasket

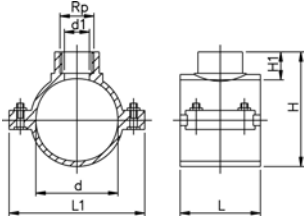

d [mm]	Rp [inch]	PN	B	M	Code	GP	kg
*20	½	16	2	M8X40	727 627 001	180	0.119
*25	½	16	2	M8X30	727 627 011	150	0.110
*25	¾	16	2	M8X30	727 627 012	150	0.123
*32	½	16	2	M8X30	727 627 021	150	0.103
*32	¾	16	2	M8X30	727 627 022	150	0.115
*32	1	16	2	M8X40	727 627 023	100	0.164
40	½	16	2	M8X40	727 627 031	100	0.136
40	¾	16	2	M8X40	727 627 032	100	0.148
40	1	16	2	M8X40	727 627 033	100	0.155
50	½	16	4	M8X40	727 627 041	100	0.200
50	¾	16	4	M8X40	727 627 042	100	0.213
50	1	16	4	M8X40	727 627 043	100	0.221
50	1 ¼	16	4	M8X40	727 627 044	100	0.225
63	½	16	4	M8X40	727 627 051	70	0.216
63	¾	16	4	M8X40	727 627 052	70	0.226
63	1	16	4	M8X40	727 627 053	70	0.232
63	1 ¼	16	4	M8X40	727 627 054	60	0.272
63	1 ½	16	4	M8X40	727 627 055	60	0.279
75	½	16	4	M8X60	727 627 061	40	0.364
75	¾	16	4	M8X60	727 627 062	40	0.376
75	1	16	4	M8X60	727 627 063	40	0.428
75	1 ¼	16	4	M8X60	727 627 064	40	0.421
75	1 ½	16	4	M8X60	727 627 065	40	0.428
75	2	16	4	M8X60	727 627 066	40	0.437
90	½	16	4	M8X60	727 627 071	34	0.412
90	¾	16	4	M8X60	727 627 072	34	0.421
90	1	16	4	M8X60	727 627 073	34	0.432
90	1 ¼	16	4	M8X60	727 627 074	34	0.472
90	1 ½	16	4	M8X60	727 627 075	30	0.474
90	2	16	4	M8X60	727 627 076	30	0.481
110	½	16	6	M8X60	727 627 081	20	0.511
110	¾	16	6	M8X50	727 627 082	20	0.523
110	1	16	6	M8X50	727 627 083	20	0.533
110	1 ¼	16	6	M8X50	727 627 084	20	0.565
110	1 ½	16	6	M8X50	727 627 085	20	0.566
110	2	16	6	M8X50	727 627 086	20	0.570
*110	3	6	6	M8X50	727 627 087	-	1.120
125	½	16	6	M8X70	727 627 091	20	0.578
125	¾	16	6	M8X50	727 627 092	20	0.520
125	1	16	6	M8X50	727 627 093	20	0.592
125	1 ¼	16	6	M8X50	727 627 094	20	0.629
125	1 ½	16	6	M8X50	727 627 095	20	0.627
125	2	16	6	M8X50	727 627 096	20	0.632
*125	3	6	6	M8X50	727 627 097	-	1.012
*125	4	6	6	M10X70	727 627 098	-	1.071

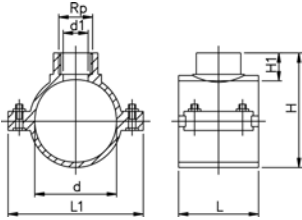

d [mm]	Rp [inch]	PN	B	M	Code	GP	kg
140	1/2	16	6	M10X70	727 627 101	-	0.830
140	3/4	16	6	M10X70	727 627 102	-	0.843
140	1	16	6	M10X70	727 627 103	-	0.849
140	1 1/4	16	6	M10X70	727 627 104	-	0.880
140	1 1/2	16	6	M10X70	727 627 105	-	0.892
140	2	16	6	M10X70	727 627 106	-	0.898
*140	3	10	6	M10X70	727 627 107	-	1.132
*140	4	10	6	M10X70	727 627 108	-	1.196
160	1/2	16	6	M10X70	727 627 111	-	0.899
160	3/4	16	6	M10X70	727 627 112	-	0.908
160	1	16	6	M10X70	727 627 113	-	0.917
160	1 1/4	16	6	M10X70	727 627 114	-	0.950
160	1 1/2	16	6	M10X70	727 627 115	-	0.954
160	2	16	6	M10X70	727 627 116	-	0.956
*160	3	10	6	M10X70	727 627 117	-	1.185
*160	4	10	6	M10X70	727 627 118	-	1.262
*180	1	10	6	M10x80	727 627 123	-	1.980
*180	1 1/4	10	6	M10x80	727 627 124	-	2.013
*180	1 1/2	10	6	M10x80	727 627 125	-	1.980
*180	2	10	6	M10x80	727 627 126	-	2.018
*180	3	10	6	M10x80	727 627 127	-	2.043
*180	4	10	6	M10x80	727 627 128	-	2.107
*200	1 1/2	10	6	M10x80	727 627 135	-	1.985
*200	2	10	6	M10x80	727 627 136	-	1.946
*200	3	10	6	M10x80	727 627 137	-	1.980
*200	4	10	6	M10x80	727 627 138	-	2.035
*225	1 1/2	10	6	M10x80	727 627 145	-	2.049
*225	2	10	6	M10x80	727 627 146	-	2.050
*225	3	10	6	M10x80	727 627 147	-	2.150
*225	4	10	6	M10x80	727 627 148	-	2.184
*250	2	10	6	M10x80	727 627 156	-	2.472
*250	3	10	6	M10x80	727 627 157	-	2.466
*250	4	10	6	M10x80	727 627 158	-	2.493
*280	2	10	6	M10x80	727 627 166	-	3.522
*280	3	10	6	M10x80	727 627 167	-	3.591
*280	4	10	6	M10x80	727 627 168	-	3.633
*315	2	10	6	M10x120	727 627 176	-	4.156
*315	3	10	6	M10x120	727 627 177	-	4.391
*315	4	10	6	M10x120	727 627 178	-	4.418

d [mm]	Rp [inch]	d1 [mm]	L [mm]	L1 [mm]	H [mm]	H1 [mm]
*20	1/2	12	46	77	59	26
*25	1/2	13	49	79	58	15
*25	3/4	13	49	79	58	15
*32	1/2	14	49	79	62	20
*32	3/4	14	49	79	62	20
*32	1	14	62	87	70	20
40	1/2	21	62	86	71	20
40	3/4	21	62	86	71	20
40	1	21	62	86	70	19
50	1/2	21	62	86	82	20
50	3/4	21	62	86	82	20
50	1	21	62	86	82	20
50	1 1/4	21	62	86	82	20
63	1/2	18	62	101	96	21
63	3/4	24	62	101	96	21
63	1	31	62	101	96	21
63	1 1/4	31	62	101	96	21
63	1 1/2	31	62	101	96	21
75	1/2	16	79	123	102	14
75	3/4	21	79	123	104	16
75	1	27	79	123	107	19
75	1 1/4	35	79	123	109	21

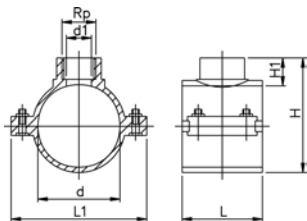

d [mm]	Rp [inch]	d1 [mm]	L [mm]	L1 [mm]	H [mm]	H1 [mm]
75	1 ½	42	79	123	109	21
75	2	53	79	123	112	24
90	½	16	87	138	116	14
90	¾	21	87	138	118	16
90	1	27	87	138	121	19
90	1 ¼	35	87	138	123	21
90	1 ½	42	87	138	123	21
90	2	53	87	138	126	24
110	½	15	99	152	150	23
110	¾	20	99	152	150	23
110	1	26	99	152	150	23
110	1 ¼	35	99	152	150	23
110	1 ½	41	99	152	150	23
110	2	51	99	152	150	23
*110	3	85	99	152	150	23
125	½	15	101	166	169	24
125	¾	20	101	166	169	24
125	1	26	101	166	169	24
125	1 ¼	35	101	166	168	23
125	1 ½	41	101	166	168	23
125	2	50	101	166	168	23
*125	3	85	139	178	180	37
*125	4	90	139	178	181	38
140	½	18	114	207	191	25
140	¾	24	114	207	191	25
140	1	30	114	207	191	25
140	1 ¼	38	114	207	191	25
140	1 ½	45	114	207	191	24
140	2	50	114	207	191	24
*140	3	85	142	208	201	38
*140	4	90	142	208	201	38
160	½	18	114	226	215	24
160	¾	24	114	226	215	24
160	1	30	114	226	215	24
160	1 ¼	37	114	226	215	24
160	1 ½	45	114	226	215	24
160	2	51	114	226	215	24
*160	3	84	142	228	222	24
*160	4	90	142	228	222	24
*180	1	30	169	262	265	38
*180	1 ¼	36	169	262	265	38
*180	1 ½	42	169	262	265	38
*180	2	54	169	262	265	38
*180	3	84	169	262	265	38
*180	4	108	169	262	265	38
*200	1 ½	45	169	262	265	38
*200	2	54	169	262	265	38
*200	3	85	169	262	265	38
*200	4	103	169	262	267	40
*225	1 ½	45	145	287	287	26
*225	2	51	145	287	287	26
*225	3	85	174	287	295	37
*225	4	103	174	287	295	38
*250	2	55	178	310	314	38
*250	3	85	178	310	314	38
*250	4	103	178	310	314	38
*280	2	51	179	335	326	31
*280	3	78	179	335	338	41
*280	4	98	179	335	338	46
*315	2	51	246	390	350	31
*315	3	78	246	390	363	41
*315	4	98	246	390	363	46

PF 2 85 523 000

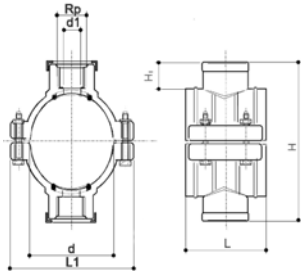

664 - Double blue clamp saddles with stainless steel reinforcing ring, flat gasket and galvanized bolts and nuts (PN16-PN10)

- water PN16-10
- suitable for PE and PVC pipes
- female thread: ISO 7 (parallel)
- material: PP
- gasket: O-ring with flat lip (NBR)
- reinforcement ring: stainless steel AISI430
- bolts and nuts : stainless steel (bolts:AISI304-A2; nuts:AISI316-A4)
- colour: blue
- B= N° of bolts
- M= bolt type
- (*) with O-ring gasket

d	Rp	PN	B	M	Code	GP	kg	d1	L	L1	H	H1
[mm]	[inch]							[mm]	[mm]	[mm]	[mm]	[mm]
*20	½	16	2	M8X40	158 001 125	150	0.152	12	46	77	84	26
*25	½	16	2	M8X30	158 001 126	150	0.130	13	49	79	80	15
*25	¾	16	2	M8X30	158 001 127	150	0.156	13	49	79	80	15
*32	½	16	2	M8X30	158 001 128	150	0.124	14	49	79	80	20
*32	¾	16	2	M8X30	158 001 129	150	0.148	14	62	87	87	20
*32	1	16	2	M8X50	158 001 130	100	0.212	14	62	87	91	20
40	½	16	2	M8X50	158 001 131	100	0.168	21	62	86	91	20
40	¾	16	2	M8X50	158 001 132	100	0.190	21	62	86	91	20
40	1	16	2	M8X50	158 001 133	100	0.204	21	62	86	89	19
50	½	16	4	M8X50	158 001 134	100	0.236	21	62	86	101	20
50	¾	16	4	M8X50	158 001 135	100	0.262	21	62	86	101	20
50	1	16	4	M8X50	158 001 136	100	0.278	21	62	86	101	20
50	1 ¼	16	4	M8X50	158 001 137	100	0.286	21	62	86	101	20
63	½	16	4	M8X50	158 001 138	60	0.254	18	62	101	115	21
63	¾	16	4	M8X50	158 001 139	60	0.274	24	62	101	115	21
63	1	16	4	M8X50	158 001 140	60	0.286	31	62	101	115	21
63	1 ¼	16	4	M8X50	158 001 142	60	0.366	31	62	101	115	21
63	1 ½	16	4	M8X50	158 001 141	60	0.380	31	62	101	115	21
75	½	16	4	M8X70	158 001 143	40	0.392	16	79	123	115	14
75	¾	16	4	M8X70	158 001 144	40	0.416	21	79	123	119	16
75	1	16	4	M8X70	158 001 145	40	0.432	27	79	123	125	19
75	1 ¼	16	4	M8X70	158 001 147	32	0.506	35	79	123	129	21
75	1 ½	16	4	M8X70	158 001 146	32	0.520	42	79	123	129	21
75	2	16	4	M8X70	158 001 148	30	0.538	53	79	123	135	24
90	½	16	4	M8X70	158 001 149	30	0.440	16	87	138	129	14
90	¾	16	4	M8X70	158 001 150	30	0.458	21	87	138	133	16
90	1	16	4	M8X70	158 001 151	30	0.480	27	87	138	139	19
90	1 ¼	16	4	M8X70	158 001 153	30	0.560	35	87	138	145	21
90	1 ½	16	4	M8X70	158 001 152	30	0.564	42	87	138	145	21
90	2	16	4	M8X70	158 001 154	30	0.578	53	87	138	151	24
110	½	16	6	M8X70	158 001 155	20	0.572	15	99	152	169	23
110	¾	16	6	M8X70	158 001 156	20	0.596	20	99	152	169	23
110	1	16	6	M8X70	158 001 157	20	0.616	26	99	152	169	23
110	1 ¼	16	6	M8X70	158 001 159	20	0.680	35	99	152	169	23
110	1 ½	16	6	M8X70	158 001 158	20	0.682	41	99	152	169	23
110	2	16	6	M8X70	158 001 160	20	0.690	51	99	152	169	23
*110	3	6	6	M8X70	158 001 161	-	1.362	85	99	152	169	23
125	½	16	6	M8X70	158 001 162	20	0.642	15	101	166	189	24
125	¾	16	6	M8X70	158 001 163	20	0.666	20	101	166	189	24
125	1	16	6	M8X70	158 001 164	20	0.670	26	101	166	189	24
125	1 ¼	16	6	M8X70	158 001 166	20	0.744	35	101	166	188	23
125	1 ½	16	6	M8X70	158 001 165	20	0.740	41	101	166	188	23
125	2	16	6	M8X70	158 001 167	20	0.766	50	101	166	188	23
*125	3	6	6	M8X70	158 001 168	-	1.238	85	139	178	188	37
*125	4	6	6	M8X70	158 001 169	-	1.322	90	139	178	188	38
140	½	16	6	M8X70	158 001 170	-	0.868	18	114	207	209	25

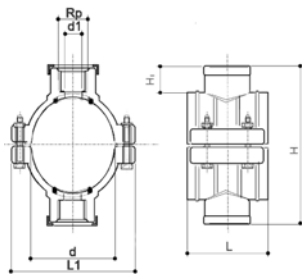

d [mm]	Rp [inch]	PN	B	M	Code	GP	kg	d1 [mm]	L [mm]	L1 [mm]	H [mm]	H1 [mm]
140	¾	16	6	M8X70	158 001 171	-	0.894	24	114	207	208	25
140	1	16	6	M8X70	158 001 172	-	0.906	30	114	207	208	25
140	1 ¼	16	6	M8X70	158 001 174	-	0.968	38	114	207	208	25
140	1 ½	16	6	M8X70	158 001 173	-	0.992	45	114	207	206	24
140	2	16	6	M8X70	158 001 175	-	1.004	50	114	207	207	24
*140	3	10	6	M8X70	158 001 176	-	1.326	85	142	208	207	38
*140	4	10	6	M8X70	158 001 177	-	1.454	90	142	208	207	38
160	½	16	6	M8X70	158 001 178	-	0.928	18	114	226	225	24
160	¾	16	6	M8X70	158 001 179	-	0.946	24	114	226	225	24
160	1	16	6	M8X70	158 001 180	-	0.964	30	114	226	225	24
160	1 ¼	16	6	M8X70	158 001 182	-	1.030	37	114	226	225	24
160	1 ½	16	6	M8X70	158 001 181	-	1.038	45	114	226	225	24
160	2	16	6	M8X70	158 001 183	-	1.042	51	114	226	225	24
*160	3	10	6	M8X70	158 001 184	-	1.376	85	142	228	225	38
*160	4	10	6	M8X70	158 001 185	-	1.530	90	142	228	225	38
*180	1	10	6	M8X70	158 001 186	-	2.234	30	169	262	303	38
*180	1 ¼	10	6	M8X70	158 001 188	-	2.300	37	169	262	303	38
*180	1 ½	10	6	M8X70	158 001 187	-	2.288	45	169	262	303	38
*180	2	10	6	M8X70	158 001 189	-	2.310	51	169	262	303	38
*180	3	10	6	M10X80	158 001 190	-	2.360	85	169	262	303	38
*180	4	10	6	M10X80	158 001 191	-	2.458	90	169	262	303	40
*200	1 ½	10	6	M10X80	158 001 192	-	2.196	45	169	262	323	38
*200	2	10	6	M10X80	158 001 193	-	2.156	51	169	262	323	38
*200	3	10	6	M10X80	158 001 194	-	2.224	85	169	262	323	38
*200	4	10	6	M10X80	158 001 195	-	2.304	90	169	262	323	40
*225	1 ½	10	6	M10X80	158 001 196	-	2.162	45	145	287	351	26
*225	2	10	6	M10X80	158 001 197	-	2.164	51	145	287	351	26
*225	3	10	6	M10X80	158 001 198	-	2.364	85	174	287	351	37
*225	4	10	6	M10X80	158 001 199	-	2.432	90	174	287	351	38
*250	2	10	6	M10X80	158 001 200	-	2.686	51	178	310	375	38
*250	3	10	6	M10X80	158 001 201	-	2.674	85	178	310	375	38
*250	4	10	6	M10X80	158 001 202	-	2.698	90	178	310	375	38

PF 2 85 523 100



POLYFAST AZ

Compression fittings



POLYFAST AZ SPARE PARTS



Split ring

- also sold as individual pieces

d [mm]	Code	GP	kg
16	158 001 218	-	0.002
20	158 001 219	-	0.003
25	158 001 220	-	0.004
32	158 001 221	-	0.005
40	158 001 222	-	0.014
50	158 001 223	-	0.018
63	158 001 224	-	0.021
75	158 001 225	-	0.060
90	158 001 226	-	0.109
110	158 001 227	-	0.145

PF 2 85 520 000



Gasket

- also sold as individual pieces

d [mm]	Code	GP	kg
16	158 001 237	-	0.001
20	158 001 238	-	0.001
25	158 001 239	-	0.002
32	158 001 240	-	0.004
40	158 001 241	-	0.006
50	158 001 242	-	0.005
63	158 001 243	-	0.012
75	158 001 244	-	0.023
90	158 001 245	-	0.037
110	158 001 246	-	0.046

PF 2 85 520 000



Thrust ring

- also sold as individual pieces

d [mm]	Code	GP	kg
16	158 001 247	-	0.003
20	158 001 248	-	0.005
25	158 001 249	-	0.007
32	158 001 250	-	0.008
40	158 001 251	-	0.005
50	158 001 252	-	0.006
63	158 001 253	-	0.017
75	158 001 254	-	0.046
90	158 001 255	-	0.079
110	158 001 256	-	0.101

PF 2 85 520 000



Nut

- also sold as individual pieces

d [mm]	Code	GP	kg
16 - 20	158 001 228	-	0.018
25	158 001 229	-	0.023
32	158 001 230	-	0.035
40	158 001 231	-	0.062
50	158 001 232	-	0.081
63	158 001 233	-	0.151
75	158 001 234	-	0.363
90	158 001 235	-	0.351
110	158 001 236	-	0.459

PF 2 85 520 000

POLYFAST AZ Compression Fittings

90° Elbow with threaded female offtake

- With stainless steel reinforcement ring (*)

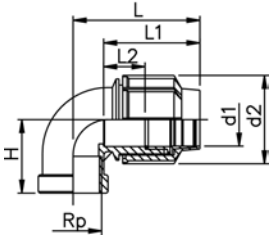

PF 2 85 520 000

d	Rp	PN	Code	GP	kg	d1	d2	L	L1	L2	H
[mm]	[inch]					[mm]	[mm]	[mm]	[mm]	[mm]	[mm]
16	1/2	10	700 627 916	200	0.059	22	46	71	58	18	50
16	3/4	10	700 627 917	200	0.062	22	46	71	58	18	50
20	1/2	10	700 627 658	200	0.059	22	46	71	58	18	50
20	3/4	10	700 627 918	200	0.059	22	46	71	58	18	50
25	1/2	10	700 627 919	150	0.089	28	54	75	60	17	35
25	3/4	10	700 627 659	150	0.081	28	54	75	60	17	35
25	1	10	700 627 920	125	0.089	28	54	75	60	17	45
32	1/2	10	700 627 581	100	0.145	34	64	85	68	18	40
32	3/4	10	700 627 582	100	0.138	34	64	85	68	18	40
32	1	10	700 627 660	100	0.126	34	64	85	68	18	40
*40	1 1/4	10	700 627 661	-	0.214	42	77	105	78	30	54
*50	1 1/2	10	700 627 662	-	0.269	52	88	105	76	27	55
*50	2	10	158 001 019	-	0.453	53	93	130	96	28	75
*63	2	10	700 627 663	-	0.483	66	106	130	95	29	70
*75	2 1/2	10	700 627 921	-	1.010	78	134	178	129	48	75
*90	3	10	700 627 922	-	1.415	93	156	227	155	62	100
*110	4	10	700 627 923	-	1.840	114	177	247	159	57	116

90° Tee with threaded male offtake

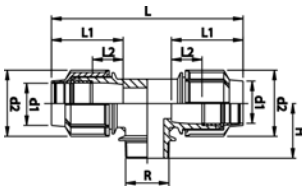

PF 2 85 520 000

d	R	PN	Code	GP	kg	d1	d2	L	L1	L2	H
[mm]	[inch]					[mm]	[mm]	[mm]	[mm]	[mm]	[mm]
16	1/2	10	700 627 924	125	0.096	22	44	134	53	28	50
16	3/4	10	700 627 925	125	0.088	22	44	134	53	28	50
20	1/2	10	700 627 926	125	0.078	22	44	137	54	26	50
20	3/4	10	700 627 927	125	0.088	22	46	143	58	18	50
25	1/2	10	700 627 976	75	0.137	28	54	150	62	18	48
25	3/4	10	700 627 928	75	0.137	28	54	150	62	18	48
25	1	10	700 627 929	75	0.134	28	54	150	62	18	50
32	3/4	10	700 627 930	45	0.206	34	64	170	68	19	50
32	1	10	700 627 931	45	0.169	34	64	170	68	19	51
40	1 1/4	10	700 627 932	-	0.347	34	64	170	68	19	53
50	1 1/2	10	700 627 933	-	0.392	52	88	210	76	27	76
63	2	10	700 627 934	-	0.693	66	106	262	95	29	82

90° Elbow with threaded male offtake

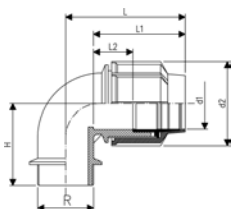

PF 2 85 520 000

d	R	PN	Code	GP	kg	d1	d2	L	L1	L2	H
[mm]	[inch]					[mm]	[mm]	[mm]	[mm]	[mm]	[mm]
16	1/2	10	700 627 935	200	0.046	22	46	71	58	18	50
16	3/4	10	700 627 960	200	0.054	22	46	71	58	19	50
20	1/2	10	700 627 936	200	0.047	22	44	69	54	26	50
20	3/4	10	700 627 961	200	0.047	22	46	71	58	18	50
25	1/2	10	700 627 937	175	0.078	28	54	75	60	17	50
25	3/4	10	700 627 938	175	0.075	28	54	75	60	17	50
25	1	10	700 627 939	150	0.076	28	54	75	60	17	50
32	1	10	700 627 853	100	0.119	34	64	85	68	18	50
40	1 1/4	10	700 627 940	-	0.215	42	77	105	77	30	76
50	1 1/2	10	700 627 941	-	0.264	52	88	110	76	26	77
63	2	10	700 627 942	-	0.443	66	106	130	95	29	82

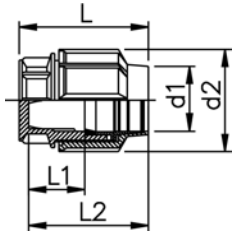

PF 2 85 520 000

End cap

d [mm]	PN	Code	GP	kg	d1 [mm]	d2 [mm]	L [mm]	L1 [mm]	L2 [mm]
16	10	700 627 943	350	0.041	22	44	59	26	56
20	10	700 627 664	350	0.042	22	44	59	26	56
25	10	700 627 665	200	0.059	28	52	63	32	59
32	10	700 627 666	125	0.082	34	60	66	27	63
40	10	700 627 667	-	0.134	52	88	87	30	81
50	10	700 627 668	-	0.082	42	77	84	31	79
63	10	700 627 669	-	0.134	66	106	108	43	103
75	10	700 627 944	-	0.791	78	134	178	55	136
90	10	700 627 945	-	1.002	93	156	208	68	162
110	10	700 627 946	-	1.317	114	177	224	71	175

Male adaptor

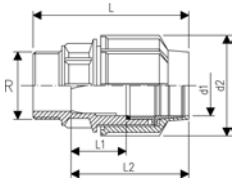

PF 2 85 520 000

d [mm]	R [inch]	PN	Code	GP	kg	d1 [mm]	d2 [mm]	L [mm]	L1 [mm]	L2 [mm]
16	½	10	700 627 854	350	0.039	22	44	73	27	52
16	¾	10	700 627 855	325	0.040	22	44	71	31	57
20	½	10	700 627 670	350	0.035	22	44	76	24	55
20	¾	10	700 627 671	325	0.037	22	44	75	25	55
25	½	10	700 627 856	200	0.050	28	52	81	32	61
25	¾	10	700 627 672	200	0.063	28	52	80	29	60
25	1	10	700 627 673	200	0.064	28	52	80	32	60
32	¾	10	700 627 857	125	0.066	34	60	83	26	63
32	1	10	700 627 674	125	0.085	34	60	83	26	63
32	1 ¼	10	700 627 675	125	0.069	34	60	81	25	60
40	1	10	700 627 955	-	0.138	42	77	104	30	78
40	1 ¼	10	700 627 676	-	0.139	42	77	105	30	78
40	1 ½	10	700 627 858	-	0.138	42	77	105	30	78
50	1 ½	10	700 627 677	-	0.160	52	88	109	32	82
50	2	10	700 627 859	-	0.165	52	88	109	32	82
63	1 ½	10	700 627 860	-	0.317	66	106	128	43	103
63	2	10	700 627 678	-	0.328	66	106	133	43	103
63	2 ½	10	700 627 861	-	0.577	65	117	160	41	119
75	2	10	700 627 862	-	0.773	78	134	173	56	136
75	2 ½	10	700 627 863	-	0.776	78	134	174	56	136
75	3	10	700 627 956	-	0.789	78	134	178	56	136
90	2	10	700 627 864	-	0.967	93	160	205	68	168
90	2 ½	10	158 001 020	-	0.978	93	156	203	68	161
90	3	10	700 627 865	-	0.993	93	156	203	68	161
90	4	10	700 627 866	-	1.038	93	156	203	68	161
110	4	10	700 627 867	-	1.301	114	177	226	71	175

Flanged joint without metal flange



PF 2 85 520 000

d [mm]	Inch	DN [mm]	PN	Code	GP	kg	d1 [mm]	d2 [mm]	d3 [mm]	d4 [mm]	L [mm]	L1 [mm]	L2 [mm]
50	2	50	10	700 627 947	-	0.541	54	93	174	125	170	36	100
63	2	50	10	700 627 948	-	0.818	65	117	174	125	193	48	126
63	2 ½	65	10	700 627 949	-	0.864	65	117	185	145	195	48	127
75	2 ½	65	10	700 627 950	-	0.979	78	134	185	145	197	104	185
75	3	80	10	700 627 951	-	1.076	78	134	200	160	197	82	162
90	3	80	10	700 627 952	-	1.666	93	160	200	160	232	65	166
90	4	100	10	700 627 953	-	1.770	93	160	220	181	232	65	166
110	4	100	10	700 627 954	-	2.091	113	181	220	181	239	107	220

Female adaptor

- With stainless steel reinforcement ring (*)



PF 2 85 520 000

d [mm]	Rp [inch]	PN	Code	GP	kg	d1 [mm]	d2 [mm]	L [mm]	L1 [mm]	L2 [mm]
16	½	10	700 627 868	325	0.046	22	44	77	25	54
16	¾	10	700 627 957	300	0.052	22	44	77	25	54
20	½	10	700 627 679	325	0.045	22	44	77	25	54
20	¾	10	700 627 869	300	0.045	22	44	77	25	54
25	½	10	700 627 870	200	0.050	28	54	87	21	63
25	¾	10	700 627 680	200	0.064	28	54	87	21	63
25	1	10	700 627 871	150	0.071	28	54	87	21	63
32	¾	10	700 627 872	125	0.100	34	64	94	21	67
32	1	10	700 627 681	125	0.095	34	64	94	21	67
*32	1 ¼	10	700 627 682	125	0.097	34	64	92	18	64
40	1	10	700 627 873	-	0.151	42	77	105	30	78
*40	1 ¼	10	700 627 683	-	0.143	42	77	105	30	78
*50	1 ¼	10	700 627 874	-	0.176	52	86	111	32	82
*50	1 ½	10	700 627 684	-	0.221	52	86	111	32	82
*63	1 ½	10	700 627 875	-	0.335	66	106	127	34	94
*63	2	10	700 627 685	-	0.371	66	106	127	34	94
*75	2	10	700 627 876	-	0.792	78	134	169	55	136
*75	2 ½	10	700 627 958	-	0.844	78	134	174	55	135
*90	2	10	700 627 877	-	1.294	93	156	202	68	160
*90	2 ½	10	158 001 021	-	1.056	93	156	202	68	160
*90	3	10	700 627 878	-	1.358	93	156	202	68	160
*110	3	10	700 627 879	-	1.556	114	177	222	71	175
*110	4	10	700 627 880	-	1.849	114	177	222	71	175

Coupling

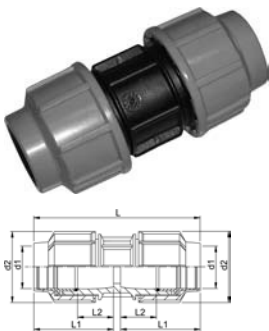

PF 2 85 520 000

d [mm]	PN	Code	GP	kg	d1 [mm]	d2 [mm]	L [mm]	L1 [mm]	L2 [mm]
16	10	700 627 881	175	0.075	22	44	117	57	32
20	10	700 627 686	175	0.078	22	44	122	60	32
25	10	700 627 687	100	0.109	28	54	119	58	16
32	10	700 627 688	50	0.151	34	64	134	66	17
40	10	700 627 689	-	0.261	42	77	178	88	40
50	10	700 627 690	-	0.339	52	88	195	96	46
63	10	700 627 691	-	0.573	66	106	214	105	45
75	10	700 627 882	-	1.412	78	134	290	143	53
90	10	700 627 883	-	1.726	93	156	290	140	42
110	10	700 627 884	-	2.271	114	177	320	150	48

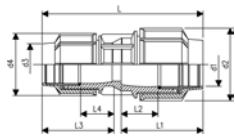

PF 2 85 520 000

Reducing coupling

d-d [mm]	PN	Code	GP	kg	d1 [mm]	d2 [mm]	d3 [mm]	d4 [mm]	L [mm]	L1 [mm]	L2 [mm]	L3 [mm]	L4 [mm]
20 - 16	10	700 627 885	175	0.071	22	44	22	44	118	60	33	56	31
25 - 20	10	700 627 710	150	0.078	28	52	22	44	121	59	30	61	33
32 - 25	10	700 627 711	75	0.103	34	60	28	52	124	61	25	61	32
40 - 32	10	700 627 712	-	0.200	42	77	34	60	164	110	62	61	25
50 - 40	10	700 627 713	-	0.482	52	88	42	77	194	125	76	110	62
63 - 50	10	700 627 714	-	0.468	66	106	52	86	205	135	75	70	21
75 - 63	10	700 627 886	-	1.164	78	134	65	117	249	129	48	116	37
90 - 63	10	700 627 959	-	1.985	93	156	65	117	355	188	87	160	82
90 - 75	10	700 627 887	-	1.900	93	156	78	134	366	188	87	175	94
110 - 90	10	700 627 888	-	2.801	114	177	93	156	411	211	93	195	87

90° Tee

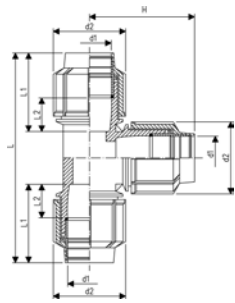

PF 2 85 520 000

d [mm]	PN	Code	GP	kg	d1 [mm]	d2 [mm]	L [mm]	L1 [mm]	L2 [mm]	H [mm]
16	10	700 627 889	100	0.111	22	44	134	53	28	68
20	10	700 627 692	100	0.124	22	44	137	54	26	69
25	10	700 627 693	50	0.166	28	54	150	62	18	75
32	10	700 627 694	30	0.252	34	64	170	68	19	85
40	10	700 627 695	-	0.423	42	77	210	78	30	105
50	10	700 627 696	-	0.481	52	88	210	75	27	105
63	10	700 627 697	-	0.922	66	106	262	95	29	130
75	6	700 627 890	-	2.205	78	134	360	129	48	180
90	6	700 627 891	-	3.255	93	156	455	175	83	227
110	6	700 627 892	-	4.125	114	177	490	182	79	224

90° Tee with threaded female offtake

- With stainless steel reinforcement ring (*)

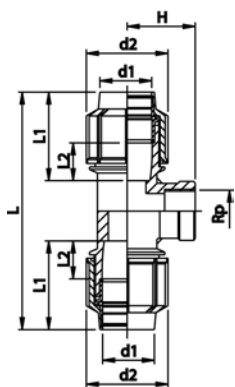

PF 2 85 520 000

d [mm]	Rp [inch]	PN	Code	GP	kg	d1 [mm]	d2 [mm]	L [mm]	L1 [mm]	L2 [mm]	H [mm]
16	1/2	10	700 627 893	125	0.092	22	44	134	53	28	48
16	3/4	10	700 627 894	125	0.096	22	44	134	53	28	53
20	1/2	10	700 627 698	125	0.084	22	44	137	54	26	48
20	3/4	10	700 627 895	125	0.084	22	44	137	54	26	53
25	1/2	10	700 627 896	75	0.142	28	54	150	62	18	32
25	3/4	10	700 627 699	75	0.136	28	54	150	62	18	32
25	1	10	700 627 897	75	0.149	28	54	150	62	18	40
32	1/2	10	700 627 898	45	0.225	34	64	170	68	19	40
32	3/4	10	700 627 899	45	0.219	34	64	170	68	19	40
32	1	10	700 627 700	45	0.207	34	64	170	68	19	40
40	1	10	158 001 022	-	0.464	44	82	238	87	27	53
*40	1 1/4	10	700 627 701	-	0.348	42	77	210	78	30	54
*50	1 1/2	10	700 627 702	-	0.403	52	88	210	76	27	55
*63	1 1/2	10	700 627 901	-	1.195	65	117	317	113	35	70
*63	2	10	700 627 703	-	0.764	66	106	262	95	29	70
*75	2 1/2	10	700 627 902	-	1.682	78	134	360	129	48	75
*90	3	10	700 627 903	-	2.450	93	156	455	175	83	101
*110	4	10	700 627 904	-	3.120	114	177	490	182	79	115

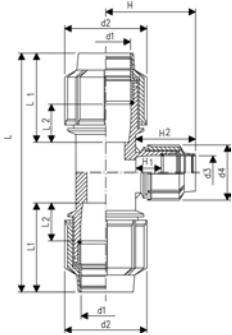

PF 2 85 520 000

90° Reducing-increasing Tee

d-d-d [mm]	PN	Code	GP	kg
20 - 16 - 20	10	700 627 905	100	0.118
20 - 25 - 20	10	700 627 906	75	0.134
25 - 20 - 25	10	700 627 907	50	0.162
25 - 32 - 25	10	700 627 908	45	0.189
32 - 25 - 32	10	700 627 909	30	0.237
40 - 32 - 40	10	700 627 850	-	0.517
50 - 40 - 50	10	700 627 910	-	0.795
63 - 50 - 63	10	700 627 911	-	1.384
75 - 63 - 75	10	700 627 977	-	2.127

d-d-d [mm]	d1 [mm]	d2 [mm]	d3 [mm]	d4 [mm]	L [mm]	L1 [mm]	L2 [mm]	L3 [mm]	L4 [mm]
20 - 16 - 20	22	46	22	46	143	58	18	57	18
20 - 25 - 20	22	46	28	54	144	58	18	59	17
25 - 20 - 25	28	54	22	46	153	58	17	58	18
25 - 32 - 25	28	54	35	64	155	59	17	65	19
32 - 25 - 32	35	64	28	54	173	64	19	63	21
40 - 32 - 40	44	82	35	64	238	87	27	66	21
50 - 40 - 50	53	93	44	82	259	96	28	94	38
63 - 50 - 63	65	117	53	93	317	113	35	90	28
75 - 63 - 75	78	134	65	117	360	129	48	113	35

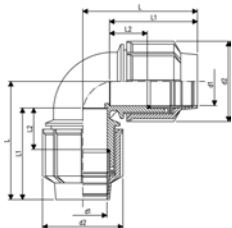

PF 2 85 520 000

90° Elbow

d [mm]	PN	Code	GP	kg	d1 [mm]	d2 [mm]	L [mm]	L1 [mm]	L2 [mm]
16	10	700 627 912	150	0.084	22	46	71	58	18
20	10	700 627 704	150	0.080	22	44	69	54	26
25	10	700 627 705	100	0.110	28	54	75	60	17
32	10	700 627 706	50	0.168	34	64	85	68	18
40	10	700 627 707	-	0.288	42	77	105	78	30
50	10	700 627 708	-	0.364	52	88	105	76	27
63	10	700 627 709	-	0.642	66	106	130	95	29
75	10	700 627 913	-	1.530	78	134	178	129	48
90	10	700 627 914	-	2.240	93	156	227	155	63
110	10	700 627 915	-	2.893	114	177	247	159	57

POLYFAST AZ CLAMP SADDLES

550 - Black clamp saddles with O-ring gasket and galvanized bolts and nuts (PN10)



- Note: sale in full box (GP) only
- B = No. of bolts
- M = bolt type

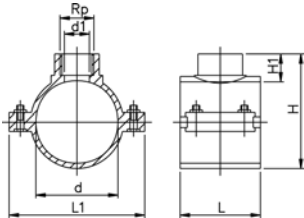

d [mm]	Rp [inch]	PN	B	M	Code	GP	kg	d1 [mm]	L [mm]	L1 [mm]	H [mm]	H1 [mm]
25	1/2	10	2	M6X35	158 001 270	200	0.055	13	36	75	50	17
25	3/4	10	2	M6X35	158 001 271	200	0.058	13	36	75	52	19
32	1/2	10	2	M6X35	158 001 272	150	0.058	13	45	80	60	17
32	3/4	10	2	M6X35	158 001 273	150	0.063	13	45	80	62	19
40	1/2	10	2	M6X35	158 001 274	130	0.062	15	45	80	68	17
40	3/4	10	2	M6X35	158 001 275	130	0.066	20	45	80	70	19
40	1	10	2	M6X35	158 001 276	130	0.069	20	45	80	70	19
50	1/2	10	2	M6X35	158 001 277	130	0.070	15	46	80	78	17
50	3/4	10	2	M6X35	158 001 278	130	0.073	22	46	80	80	19
50	1	10	2	M6X35	158 001 279	130	0.076	28	46	80	80	19
63	1/2	10	4	M8X60	158 001 280	70	0.217	15	60	100	90	17
63	3/4	10	4	M8X60	158 001 281	70	0.218	22	60	100	92	19
63	1	10	4	M8X60	158 001 282	70	0.221	28	60	100	92	19
75	1/2	10	4	M8X60	158 001 283	40	0.269	15	80	110	110	17
75	3/4	10	4	M8X60	158 001 284	40	0.248	22	80	110	112	19
75	1	10	4	M8X60	158 001 285	40	0.251	28	80	110	112	19
75	1 1/4	10	4	M8X60	158 001 287	40	0.257	35	80	110	116	23
75	1 1/2	10	4	M8X60	158 001 286	40	0.259	41	80	110	116	23
90	1/2	10	4	M8X70	158 001 288	35	0.289	15	80	125	123	17
90	3/4	10	4	M8X70	158 001 289	35	0.293	22	80	125	125	19
90	1	10	4	M8X70	158 001 290	35	0.294	28	80	125	125	19
90	1 1/4	10	4	M8X70	158 001 292	35	0.268	35	80	125	129	23
90	1 1/2	10	4	M8X70	158 001 291	30	0.301	41	80	125	129	23
110	1/2	10	4	M8X70	158 001 293	30	0.322	15	82	147	141	17
110	3/4	10	4	M8X70	158 001 294	30	0.324	22	82	147	143	19
110	1	10	4	M8X70	158 001 295	30	0.327	28	82	147	143	19
110	1 1/4	10	4	M8X70	158 001 297	30	0.330	35	82	147	147	23
110	1 1/2	10	4	M8X70	158 001 296	30	0.332	41	82	147	147	23
110	2	10	4	M8X70	158 001 298	30	0.342	41	82	147	148	24

PF 2 85 523 050



PRIMOFIT®

PRIMOFIT®

Steel x PE, galvanised

PRIMOFIT is a compression fitting which offers full end load capability. Additionally it bears a misalignment of the connected pipes up to 3° per compression joint. Transition Coupling according to EN 10284 for connection of galvanised steel pipes with measurements according to ISO 65 with polyethylene pipes according to EN 1555-2 (Gas) and EN 12201-2 (Water), with material PE 100 or PE 80.

Please pay attention to the different wall thicknesses of the PE pipe!

Pipe Specification

	PE, EN 12201-2/Water			PE, EN 1555-2/Gas		Steel/ISO 65	
SDR	7,4	11	17,6(17)	11	17,6	-	
S	3,2	5	8,3	5	8,3	-	
Da [mm]	s [mm]	s [mm]	s [mm]	s [mm]	s [mm]	Dim. [inch]	D [mm]
20	3,0	2,0	-	3,0	2,3	1/2	21,3
25	3,5	2,3	2,0(2,0)	3,0*	2,3	3/4	26,9
32	4,4	3,0	2,0(2,0)	3,0*	2,3	1	33,7
40	5,5	3,7	2,3(2,4)	3,7	2,3	1 1/4	42,4
50	6,9	4,6	2,9(3,0)	4,6	2,9	1 1/2	48,3
63	8,6	5,8	3,6(3,8)	5,8	3,6	2	60,3

Da/s ... nominal outer diameter/ wall thickness of the PE pipe

D ... nominal outer diameter of the steel pipe

* For Da 25 and 32 s=2,0mm are allowed for existing pipe services <0,1 bar.

Important

Scope of delivery includes the stiffener.

To choose the correct coupling, please pay attention to the wall thickness given in the assortment-tables together with the pipe diameter.

Applications

For the different applications please refer to the individual appropriate International, European or National Application Standards.

The max. operating pressure is depending upon PE pipe specification and local regulations!

Seal	Medium	max. working pressure	max. working temperature
NBR	Gas*	5 bar	40°C
	Water**	16 bar	40°C
EPDM	Potable Water	16 bar	40°C
FPM	Fuels***	10 bar	40°C

* LP Gas (not permitted in all countries with PE) and Natural Gas.

Steel – PE joints are not allowed for in-house (natural) gas installation; please refer to the FIREJOINT products, the fire resistant version of PRIMOFIT.

** EN 12502 part 3 gives indication for the applicability of hot dip galvanised iron materials for specific water conditions.

*** Unleaded and leaded petrol and diesel.

Materials

Malleable cast iron EN-GJMW-400-5 acc. to EN 1562, sealing materials as above. Corrosion protection by hot dip galvanising according to EN 10284.

Please refer to the technical section for details regarding: pipe specification, fitting instruction, applications and approvals.

PRIMOFIT



Coupling, short, galvanized equal, for ISO 65 Steel pipe to PE SDR 7,4/S 3,2

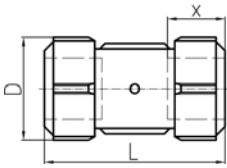

PF 1 27 140 011

Dim. St [inch]	Dim. PE [mm]	NBR Code	GP	kg	D [mm]	L [mm]	x [mm]	x1 [mm]	
1/2	20 x 3,0	775 102 701	-	0.378	45	85	30 - 34	31 - 33	
3/4	25 x 3,5	775 102 702	-	0.403	51	89	30 - 34	31 - 33	
1	32 x 4,4	775 102 703	-	0.632	59	95	30 - 34	31 - 33	
1 1/4	40 x 5,5	775 102 704	-	0.760	68	96	30 - 36	32 - 38	
1 1/2	50 x 6,9	775 102 705	-	0.900	75	103	32 - 38	35 - 43	
2	63 x 8,6	775 102 706	-	1.680	96	113	36 - 42	39 - 47	



Coupling, short, galvanized equal, for ISO 65 Steel pipe to PE SDR 11/S 5

*** according to EN 1555-2

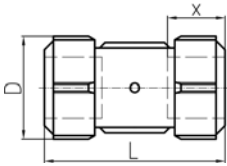

PF 1 27 140 011

	Dim. St [inch]	Dim. PE [mm]	NBR Code	EPDM Code	FPM Code	GP	kg	
***	1/2	20 x 2,0	775 102 501	-	-	-	0.320	
	3/4	25 x 2,3	775 102 502	-	-	-	0.408	
	3/4	25 x 3,0	775 102 442	-	-	-	0.408	
	1	32 x 3,0	775 102 503	775 106 503	-	-	-	
	1 1/4	40 x 3,7	775 102 504	-	-	-	0.760	
	1 1/2	50 x 4,6	775 102 505	-	-	-	0.920	
	2	63 x 5,8	775 102 506	-	775 108 506	-	1.210	

	Dim. St [inch]	Dim. PE [mm]	D [mm]	L [mm]	x [mm]	x1 [mm]	
***	1/2	20 x 2,0	45	85	30 - 34	31 - 33	
	3/4	25 x 2,3	51	89	30 - 34	31 - 33	
	3/4	25 x 3,0	51	89	30 - 34	31 - 33	
	1	32 x 3,0	59	95	30 - 34	31 - 33	
	1 1/4	40 x 3,7	68	96	30 - 36	32 - 38	
	1 1/2	50 x 4,6	75	103	32 - 38	35 - 43	
	2	63 x 5,8	96	113	36 - 42	39 - 47	



Coupling, short, galvanized reducing, for ISO 65 Steel pipe to PE SDR 11/S 5

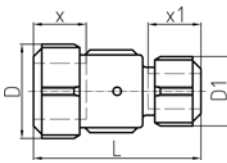

PF 1 27 140 010

Dim. St [inch]	Dim. PE [mm]	NBR Code	GP	kg	D [mm]	D1 [mm]	L [mm]	x [mm]	x1 [mm]	
1/2	25 x 2,3	775 102 526	-	0.328	45	51	90	30 - 34	31 - 33	
3/4	32 x 3,0	775 102 531	-	0.540	51	59	97	30 - 34	31 - 33	
1	40 x 3,7	775 102 535	-	0.740	59	68	97	30 - 34	32 - 38	
1 1/4	32 x 3,0	775 102 516	-	0.700	68	59	98	30 - 36	31 - 33	
1 1/4	50 x 4,6	775 102 538	-	0.757	68	75	100	30 - 36	35 - 43	
1 1/2	40 x 3,7	775 102 520	-	0.860	75	68	97	32 - 38	32 - 38	
1 1/2	63 x 5,8	775 102 540	-	1.540	75	96	112	32 - 38	39 - 47	
2	50 x 4,6	775 102 525	-	1.440	96	75	112	36 - 42	35 - 43	



Coupling, short, galvanised equal, for ISO 65 Steel pipe to PE SDR 17,6/S 8,3

*** according to EN 1555-2

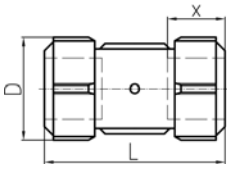

	Dim. St [inch]	Dim. PE [mm]	NBR Code	GP	kg	D [mm]	L [mm]	x [mm]	x1 [mm]
***	3/4	25 x 2,0	775 102 602	-	0.403	51	89	30 - 34	31 - 33
	3/4	25 x 2,3	775 102 452	-	0.462	51	89	30 - 34	31 - 33
***	1	32 x 2,0	775 102 603	-	0.644	59	95	30 - 34	31 - 33
	1	32 x 2,3	775 102 453	-	0.644	59	95	30 - 34	31 - 33
	1 1/4	40 x 2,3	775 102 604	-	0.770	68	96	30 - 36	32 - 38
	1 1/2	50 x 2,9	775 102 605	-	0.900	75	103	32 - 38	35 - 43
	2	63 x 3,6	775 102 606	-	1.836	96	113	36 - 42	39 - 47

PF 1 27 140 777



Coupling, short, galvanised reducing, for ISO 65 Steel pipe to PE SDR 17,6/S 8,3

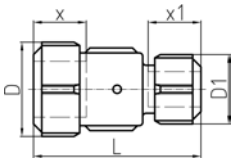

	Dim. St [inch]	Dim. PE [mm]	NBR Code	GP	kg	D [mm]	D1 [mm]	L [mm]	x [mm]	x1 [mm]
	1	25 x 2,0	775 102 613	-	0.469	59	51	96	30 - 34	31 - 33

PF 1 27 140 777



Male Adaptor, galvanised for PE SDR 11/S 5 to R/ISO 7

*** according to EN 1555-2

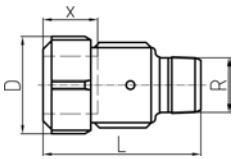

	Dim. PE [mm]	Dim. R [inch]	NBR Code	FPM Code	GP	kg	D [mm]	L [mm]	x [mm]
***	20 x 2,0	1/2	775 202 201	-	-	0.260	45	73	31 - 33
	25 x 2,3	3/4	775 202 202	-	20	0.300	51	79	31 - 33
	25 x 3,0	3/4	775 202 442	-	-	0.300	51	79	31 - 33
	32 x 3,0	1	775 202 203	775 208 203	-	0.422	59	89	31 - 33
	40 x 3,7	1 1/4	775 202 204	-	-	0.600	68	92	32 - 38
	50 x 4,6	1 1/2	775 202 205	775 208 205	-	0.729	75	96	35 - 43
	63 x 5,8	2	775 202 206	775 208 206	-	0.997	96	106	39 - 47

PF 1 27 140 210

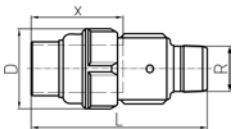

Male Adaptor with GRP Sleeving Nut, galvanised for PE SDR 11/S 5 to R/ISO 7

	Dim. PE [mm]	Dim. R [inch]	NBR Code	D [mm]	L [mm]	x [mm]
	20 x 2,0	1/2	775 222 101	45	109	68
	25 x 2,3	3/4	775 222 102	51	123	76
	32 x 3,0	1	775 222 103	59	124	67

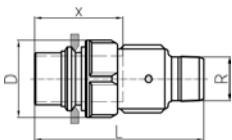

Boss Male Adaptor with GRP Sleeving Nut + fixing clip, galvanised for PE SDR 11/S 5 to R/ISO 7

	Dim. PE [mm]	Dim. R [inch]	NBR Code	D [mm]	L [mm]	x [mm]
	25 x 2,3	3/4	775 262 202	51	123	76

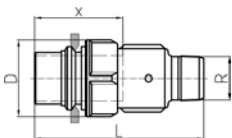

Male Adaptor with GRP Sleeving Nut + fixing clip, galvanised for PE SDR 11/S 5 to R/ISO 7

Dim. PE [mm]	Dim. R [inch]	NBR Code	D [mm]	L [mm]	x [mm]
20 x 2,0	½	775 232 201	45	109	68
25 x 2,3	¾	775 232 202	51	123	76
32 x 3,0	1	775 232 203	59	124	67



Male Adaptor without insert stiffener, galvanised for PE SDR 11/S 5 to R/ISO 7

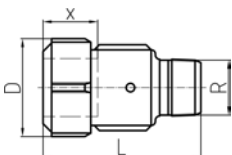

Dim. PE [mm]	Dim. R [inch]	NBR Code	D [mm]	L [mm]	x [mm]
20 x 2,0	½	775 202 771	45	73	31 - 33
25 x 2,3	¾	775 202 772	51	79	31 - 33
32 x 3,0	1	775 202 773	59	89	31 - 33
40 x 3,7	1 ¼	775 202 774	68	92	32 - 38
50 x 4,6	1 ½	775 202 775	75	96	35 - 43
63 x 5,8	2	775 202 776			



Male Adaptor, galvanised for PE SDR 17,6/S 8,3 to R/ISO 7

*** according to EN 1555-2

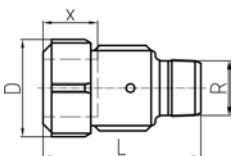

	Dim. PE [mm]	Dim. R [inch]	NBR Code	GP	kg	D [mm]	L [mm]	x [mm]
***	25 x 2,0	¾	775 202 602	-	0.295	51	79	31 - 33
***	25 x 2,3	¾	775 202 452	-	0.295	51	79	31 - 33
***	32 x 2,0	1	775 202 603	-	0.460	59	89	31 - 33
***	32 x 2,3	1	775 202 453	-	0.460	59	89	31 - 33
***	40 x 2,3	1 ¼	775 202 454	5	0.600	68	92	32 - 38
***	50 x 2,9	1 ½	775 202 455	5	0.760	75	96	35 - 43
***	63 x 3,6	2	775 202 456	5	1.343	96	106	39 - 47

PF 1 27 140 011



Female Adaptor, galvanised for PE SDR 11/S 5 to Rp/ISO 7

*** according to EN 1555-2

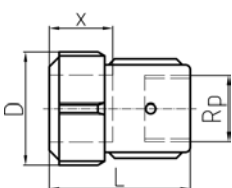

	Dim. PE [mm]	Dim. Rp [inch]	NBR Code	GP	kg	D [mm]	L [mm]	x [mm]
***	20 x 2,0	½	775 212 201	-	0.227	45	58	31 - 33
***	25 x 2,3	¾	775 212 202	-	0.300	51	62	31 - 33
***	25 x 3,0	¾	775 212 442	-	0.300	51	62	31 - 33
***	32 x 3,0	1	775 212 203	10	0.400	59	68	31 - 33
***	40 x 3,7	1 ¼	775 212 204	-	0.560	68	70	32 - 38
***	50 x 4,6	1 ½	775 212 205	-	0.700	75	75	35 - 43
***	63 x 5,8	2	775 212 206	-	1.308	96	83	39 - 47

PF 1 27 140 310

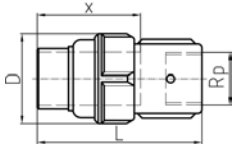

Female Adaptor with GRP Sleeving Nut, galvanised equal, for PE SDR 11/S 5 to Rp/ISO 7

Dim. PE [mm]	Dim. Rp [inch]	NBR Code	D [mm]	L [mm]	x [mm]
25 x 2,3	¾	775 322 102	51	98	76
32 x 3,0	1	775 322 103	59	112	67



Female Adapter without insert stiffener, galvanised for PE SDR 11/S 5 to Rp/ISO 7

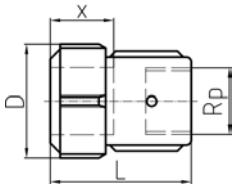

Dim. PE [mm]	Dim. Rp [inch]	NBR Code	D [mm]	L [mm]	x [mm]
20 x 2,0	½	775 212 771	45	58	31 - 33
25 x 2,3	¾	775 212 772	51	62	31 - 33
32 x 3,0	1	775 212 773	59	68	31 - 33
40 x 3,7	1 ¼	775 212 774	68	70	32 - 38
50 x 4,6	1 ½	775 212 775	75	75	35 - 43
63 x 5,8	2	775 212 776	96	83	39 - 47



Female Adaptor, galvanised for PE SDR 17,6/S 8,3 to Rp/ISO 7

*** according to EN 1555-2

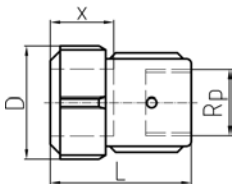

PF 1 27 140 011

	Dim. PE [mm]	Dim. Rp [inch]	NBR Code	GP	kg	D [mm]	L [mm]	x [mm]
***	25 x 2,3	¾	775 212 452	-	0.300	51	63	30 - 34
***	32 x 2,3	1	775 212 453	-	0.400	59	68	30 - 34
***	40 x 2,3	1 ¼	775 212 454	5	0.560	68	70	32 - 38
***	50 x 2,9	1 ½	775 212 455	5	0.700	75	75	35 - 43
***	63 x 3,6	2	775 212 456	5	1.308	96	83	39 - 47



Elbow, galvanised for ISO 65 Steel pipe to PE SDR 11/S 5

*** according to EN 1555-2

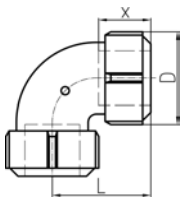

PF 1 27 140 400

	Dim. St [inch]	Dim. PE [mm]	NBR Code	FPM Code	GP	kg
***	¾	25 x 2,3	775 402 502	-	-	0.460
***	¾	25 x 3,0	775 402 442	-	-	0.460
***	1	32 x 3,0	775 402 503	-	-	0.660
***	1 ¼	40 x 3,7	775 402 504	-	-	0.889
***	1 ½	50 x 4,6	775 402 505	-	-	1.140
***	2	63 x 5,8	775 402 506	775 408 506	-	-

	Dim. St [inch]	Dim. PE [mm]	D [mm]	L [mm]	x [mm]	x1 [mm]
***	¾	25 x 2,3	51	59	30 - 34	31 - 33
***	¾	25 x 3,0	51	59	30 - 34	31 - 33
***	1	32 x 3,0	59	59	30 - 34	31 - 33
***	1 ¼	40 x 3,7	68	59	30 - 36	32 - 38
***	1 ½	50 x 4,6	75	78	32 - 38	35 - 43
***	2	63 x 5,8	96	75	36 - 42	39 - 47

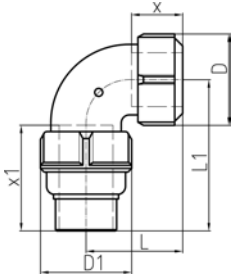

Elbow with GRP Sleeving Nut, galvanised for ISO 65 Steel pipe to PE SDR 11/S 5

Dim. St [inch]	Dim. PE [mm]	NBR Code	D [mm]	L [mm]	x [mm]	x1 [mm]
¾ 1	25 x 2,3	775 412 152	51	103	30 - 34	76
	32 x 3,0	775 412 153	59	94	30 - 34	67

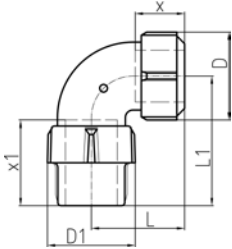

Elbow with Anti-Shear-Nut, galvanised for ISO 65 Steel pipe to PE SDR 11/S 5

Dim. St [inch]	Dim. PE [mm]	NBR Code	D [mm]	L [mm]	x [mm]	x1 [mm]
¾	25 x 2,3	775 412 752	51	83	30 - 34	56



Elbow, galvanised for ISO 65 Steel pipe to PE SDR 17,6/S 8,3

*** according to EN 1555-2

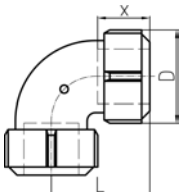

PF 1 27 140 410

	Dim. St [inch]	Dim. PE [mm]	NBR Code	GP	kg	D [mm]	L [mm]	x [mm]	x1 [mm]
***	1	32 x 2,3	775 402 453	-	0.660	59	59	30 - 34	31 - 33
***	1 ¼	40 x 2,3	775 402 454	-	0.889	68	59	30 - 36	32 - 38
***	1 ½	50 x 2,9	775 402 455	-	1.140	75	78	32 - 38	35 - 43
***	2	63 x 3,6	775 402 456	-	1.615	96	75	36 - 42	39 - 47



Tee, galvanised for ISO 65 Steel pipe to PE SDR 11/S 5

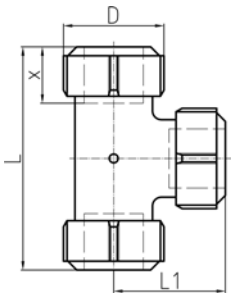

Dim. St [inch]	Dim. PE [mm]	FPM Code	GP	kg	D [mm]	L [mm]	L1 [mm]	x [mm]	x1 [mm]
2	63 x 5,8	775 308 226	5	2.240	96	166	83	39 - 47	36 - 42



Threaded Outlet Tee, galvanized for PE SDR 11/S 5 to Rp/ISO 7

Dim. PE [mm]	Dim. Rp [inch]	NBR Code	FPM Code	GP	kg	D [mm]	L [mm]	L1 [mm]	x [mm]
32 x 3,0	1	775 312 203	-	-	0.718	59	112	38	31 - 33
63 x 5,8	2	-	775 318 206	-	2.000	96	155	62	39 - 47

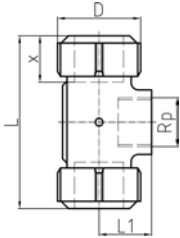

PF 1 27 140 610



Cap, galvanized for PE SDR 11/S 5

*** according to EN 1555-2

	Dim. PE [mm]	NBR Code	GP	kg	D [mm]	L [mm]	x [mm]
***	20 x 2,0	775 452 201	-	0.200	45	46	31 - 33
	25 x 2,3	775 452 202	-	0.240	51	48	31 - 33
	25 x 3,0	775 452 442	-	0.240	51	48	31 - 33
	32 x 3,0	775 452 203	-	0.329	59	52	31 - 33
	40 x 3,7	775 452 204	-	0.492	68	53	32 - 38
	50 x 4,6	775 452 205	-	0.620	75	57	35 - 43
	63 x 5,8	775 452 206	-	1.140	96	60	39 - 47

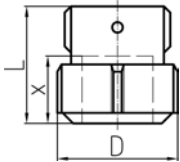

PF 1 27 140 710



Insert Stiffener for PE SDR 17,6/S 8,3

*** according to EN 1555-2

	Dim. PE [mm]	Code	GP	kg
***	25 x 2,0	775 950 302	50	0.040
	25 x 2,3	780 888 925	-	0.010
***	32 x 2,0	775 950 303	-	0.053
	32 x 2,3	780 925 551	-	0.053
***	40 x 2,3	775 950 354	-	0.044
***	50 x 2,9	775 950 255	25	0.061
***	63 x 3,6	775 950 256	25	0.094

PF 1 27 148 100

Index

Code	Page
09202002P	128
09202504P	128
158 001 000	122
158 001 001	122
158 001 002	122
158 001 003	123
158 001 004	131
158 001 005	131
158 001 006	131
158 001 007	131
158 001 008	131
158 001 009	131
158 001 015	125
158 001 016	125
158 001 017	127
158 001 018	127
158 001 019	151
158 001 020	152
158 001 021	153
158 001 022	154
158 001 125	147
158 001 126	147
158 001 127	147
158 001 128	147
158 001 129	147
158 001 130	147
158 001 131	147
158 001 132	147
158 001 133	147
158 001 134	147
158 001 135	147
158 001 136	147
158 001 137	147
158 001 138	147
158 001 139	147
158 001 140	147
158 001 141	147
158 001 142	147
158 001 143	147
158 001 144	147
158 001 145	147
158 001 146	147
158 001 147	147
158 001 148	147
158 001 149	147
158 001 150	147
158 001 151	147
158 001 152	147
158 001 153	147
158 001 154	147
158 001 155	147
158 001 156	147
158 001 157	147
158 001 158	147
158 001 159	147
158 001 160	147
158 001 161	147
158 001 162	147
158 001 163	147
158 001 164	147
158 001 165	147
158 001 166	147
158 001 167	147
158 001 168	147
158 001 169	147
158 001 170	147
158 001 171	148

Code	Page
158 001 172	148
158 001 173	148
158 001 174	148
158 001 175	148
158 001 176	148
158 001 177	148
158 001 178	148
158 001 179	148
158 001 180	148
158 001 181	148
158 001 182	148
158 001 183	148
158 001 184	148
158 001 185	148
158 001 186	148
158 001 187	148
158 001 188	148
158 001 189	148
158 001 190	148
158 001 191	148
158 001 192	148
158 001 193	148
158 001 194	148
158 001 195	148
158 001 196	148
158 001 197	148
158 001 198	148
158 001 199	148
158 001 200	148
158 001 201	148
158 001 202	148
158 001 218	150
158 001 219	150
158 001 220	150
158 001 221	150
158 001 222	150
158 001 223	150
158 001 224	150
158 001 225	150
158 001 226	150
158 001 227	150
158 001 228	150
158 001 229	150
158 001 230	150
158 001 231	150
158 001 232	150
158 001 233	150
158 001 234	150
158 001 235	150
158 001 236	150
158 001 237	150
158 001 238	150
158 001 239	150
158 001 240	150
158 001 241	150
158 001 242	150
158 001 243	150
158 001 244	150
158 001 245	150
158 001 246	150
158 001 247	150
158 001 248	150
158 001 249	150
158 001 250	150
158 001 251	150
158 001 252	150
158 001 253	150

Code	Page
158 001 254	150
158 001 255	150
158 001 256	150
158 001 270	156
158 001 271	156
158 001 272	156
158 001 273	156
158 001 274	156
158 001 275	156
158 001 276	156
158 001 277	156
158 001 278	156
158 001 279	156
158 001 280	156
158 001 281	156
158 001 282	156
158 001 283	156
158 001 284	156
158 001 285	156
158 001 286	156
158 001 287	156
158 001 288	156
158 001 289	156
158 001 290	156
158 001 291	156
158 001 292	156
158 001 293	156
158 001 294	156
158 001 295	156
158 001 296	156
158 001 297	156
158 001 298	156
158 001 578	126
158 001 579	126
158 001 580	126
158 001 581	126
158 001 582	126
158 001 583	126
158 001 584	127
158 001 585	127
158 001 586	127
158 001 587	127
158 001 588	127
158 001 589	127
158 001 692	123
158 001 710	123
158 001 713	134
158 001 714	134
158 001 715	134
158 001 716	134
158 001 717	134
158 001 718	134
158 001 719	134
158 001 720	134
158 001 721	134
158 001 722	134
158 001 723	135
158 001 724	135
158 001 725	135
158 001 727	121
158 001 728	115
158 001 729	115
158 001 730	118
158 001 731	118
158 001 732	121
158 001 733	121
158 001 777	142

Index

Code	Page
158 001 778	142
158 001 779	142
158 001 872	133
158 001 874	133
158 001 876	133
158 001 919	128
158 001 920	128
158 050 437	128
158 050 438	128
158 050 439	128
158 050 440	128
158 050 441	128
158 050 442	121
158 050 443	121
160 050 520	62
160 050 521	62
160 050 522	62
160 050 523	62
160 050 620	62
160 050 621	62
160 050 622	62
160 050 623	62
173 103 045	64
173 103 056	65
173 103 075	65
173 103 076	65
173 103 080	65
173 103 081	65
173 103 082	64
173 103 083	64
173 103 084	64
173 103 105	65
173 281 925	37
193 103 031	64
193 103 032	64
193 103 033	64
193 103 034	64
193 103 035	64
193 103 036	64
193 103 037	64
193 103 038	64
193 103 039	64
193 103 040	64
193 103 042	64
193 103 043	64
193 103 044	64
193 104 038	64
193 104 039	64
193 104 042	64
193 127 017	61
193 127 027	61
193 127 037	61
193 127 047	61
193 127 057	61
193 127 067	61
193 127 077	61
193 127 097	61
193 127 107	61
193 127 117	61
193 127 127	61
193 130 037	41
193 130 047	41
193 130 057	41
193 130 067	41
193 130 077	41
193 130 087	41
193 130 097	41

Code	Page
193 130 107	41
193 130 117	41
193 130 127	41
193 130 137	41
193 130 147	41
193 130 157	41
193 130 234	61
193 130 237	61
193 130 244	61
193 130 247	61
193 130 254	61
193 130 257	61
193 130 264	61
193 130 267	61
193 130 274	61
193 130 277	61
193 130 284	61
193 130 287	61
193 130 294	61
193 130 297	61
193 130 304	61
193 130 307	61
193 130 314	61
193 130 317	61
193 130 324	61
193 130 327	61
193 130 334	61
193 130 337	61
193 130 347	61
193 130 357	61
193 130 432	46
193 130 434	46
193 130 452	46
193 130 454	46
193 130 462	46
193 130 464	46
193 130 472	46
193 130 474	46
193 130 492	46
193 130 494	46
193 130 604	52
193 130 614	46
193 130 624	46
193 130 634	46
193 130 637	52
193 130 644	52
193 130 647	52
193 130 654	52
193 130 657	52
193 130 664	52
193 130 667	52
193 130 674	52
193 130 677	52
193 130 684	52
193 130 687	52
193 130 694	52
193 130 697	52
193 130 704	52
193 130 707	52
193 130 714	52
193 130 717	52
193 130 724	52
193 130 727	52
193 130 734	52
193 130 737	52
193 130 804	53
193 130 814	47

Code	Page
193 130 824	47
193 130 834	47
193 130 837	53
193 130 844	53
193 130 847	53
193 130 854	53
193 130 857	53
193 130 864	53
193 130 867	53
193 130 874	53
193 130 877	53
193 130 884	53
193 130 887	53
193 130 894	53
193 130 897	53
193 130 904	53
193 130 907	53
193 130 914	53
193 130 917	53
193 130 924	53
193 130 927	53
193 130 934	53
193 130 937	53
193 131 037	41
193 131 047	41
193 131 057	41
193 131 067	41
193 131 077	41
193 131 087	41
193 131 097	41
193 131 107	41
193 131 117	41
193 131 127	41
193 131 137	41
193 131 147	41
193 131 157	41
193 131 234	60
193 131 237	60
193 131 244	60
193 131 247	60
193 131 254	60
193 131 257	60
193 131 264	60
193 131 267	60
193 131 274	60
193 131 277	60
193 131 284	60
193 131 287	60
193 131 294	60
193 131 297	60
193 131 304	60
193 131 307	60
193 131 314	60
193 131 317	60
193 131 324	60
193 131 327	60
193 131 334	60
193 131 337	60
193 131 347	60
193 131 357	60
193 131 402	48
193 131 403	48
193 131 404	48
193 131 405	48
193 131 412	43
193 131 413	43
193 131 414	43

Index

Code	Page
193 131 422	43
193 131 423	43
193 131 424	43
193 131 437	48
193 131 442	48
193 131 443	48
193 131 444	48
193 131 445	48
193 131 447	48
193 131 452	48
193 131 453	48
193 131 454	48
193 131 455	48
193 131 457	48
193 131 462	48
193 131 463	48
193 131 464	48
193 131 465	48
193 131 467	48
193 131 472	48
193 131 473	48
193 131 474	48
193 131 475	48
193 131 477	48
193 131 482	48
193 131 483	48
193 131 484	48
193 131 485	48
193 131 487	48
193 131 492	48
193 131 493	48
193 131 494	48
193 131 495	48
193 131 497	48
193 131 502	48
193 131 503	48
193 131 504	48
193 131 505	48
193 131 507	48
193 131 512	48
193 131 513	48
193 131 514	48
193 131 515	48
193 131 517	48
193 131 522	48
193 131 523	48
193 131 524	48
193 131 525	49
193 131 527	49
193 131 532	49
193 131 533	49
193 131 534	49
193 131 535	49
193 131 537	49
193 131 547	49
193 131 557	49
193 131 632	45
193 131 633	45
193 131 634	45
193 131 932	44
193 131 933	44
193 131 934	44
193 131 952	44
193 131 953	44
193 131 954	44
193 131 962	44
193 131 963	44

Code	Page
193 131 964	44
193 131 967	44
193 131 972	44
193 131 973	44
193 131 974	44
193 131 992	44
193 131 993	44
193 131 994	44
193 131 997	44
193 132 402	50
193 132 403	50
193 132 404	50
193 132 405	50
193 132 412	44
193 132 413	44
193 132 414	44
193 132 422	44
193 132 423	44
193 132 424	44
193 132 435	44
193 132 436	50
193 132 437	50
193 132 442	50
193 132 443	50
193 132 444	50
193 132 445	50
193 132 446	50
193 132 447	50
193 132 452	50
193 132 453	50
193 132 454	50
193 132 455	50
193 132 456	50
193 132 457	50
193 132 462	50
193 132 463	50
193 132 464	50
193 132 465	50
193 132 466	50
193 132 467	50
193 132 472	50
193 132 473	50
193 132 474	50
193 132 475	50
193 132 476	50
193 132 477	50
193 132 482	50
193 132 483	50
193 132 484	50
193 132 485	50
193 132 486	50
193 132 487	50
193 132 492	50
193 132 493	50
193 132 494	50
193 132 495	50
193 132 496	50
193 132 497	50
193 132 502	50
193 132 503	50
193 132 504	50
193 132 505	50
193 132 506	51
193 132 507	51
193 132 512	51
193 132 513	51
193 132 514	51

Code	Page
193 132 515	51
193 132 516	51
193 132 517	51
193 132 522	51
193 132 523	51
193 132 524	51
193 132 525	51
193 132 526	51
193 132 527	51
193 132 532	51
193 132 533	51
193 132 534	51
193 132 535	51
193 132 536	51
193 132 537	51
193 132 544	51
193 132 545	51
193 132 546	51
193 132 547	51
193 132 554	51
193 132 555	51
193 132 556	51
193 132 557	51
193 135 009	27
193 135 010	27
193 135 019	27
193 135 020	27
193 135 029	27
193 135 030	27
193 135 039	27
193 135 040	27
193 135 041	27
193 135 049	27
193 135 050	27
193 135 051	27
193 135 059	27
193 135 060	27
193 135 061	27
193 135 069	27
193 135 070	27
193 135 071	27
193 135 079	27
193 135 080	27
193 135 081	27
193 135 099	28
193 135 100	28
193 135 101	28
193 135 129	28
193 135 130	28
193 135 131	28
193 135 159	28
193 135 160	28
193 135 161	28
193 149 237	42
193 149 247	42
193 149 257	42
193 149 267	42
193 149 277	42
193 149 287	42
193 149 297	42
193 149 307	42
193 149 317	42
193 149 327	42
193 149 337	42
193 149 347	42
193 149 357	42
193 149 437	42

Index

Code	Page
193 149 447	42
193 149 457	42
193 149 467	42
193 149 477	42
193 149 487	42
193 149 497	42
193 149 507	42
193 149 517	42
193 149 527	42
193 149 537	42
193 149 547	42
193 149 557	42
193 152 034	55
193 152 035	55
193 152 036	55
193 152 037	55
193 152 044	55
193 152 045	55
193 152 046	55
193 152 047	55
193 152 054	55
193 152 055	55
193 152 056	55
193 152 057	55
193 152 064	55
193 152 065	55
193 152 066	55
193 152 067	55
193 152 074	55
193 152 075	55
193 152 076	55
193 152 077	55
193 152 084	55
193 152 085	55
193 152 086	55
193 152 087	55
193 152 094	55
193 152 095	55
193 152 096	55
193 152 097	55
193 152 104	55
193 152 105	55
193 152 106	55
193 152 107	55
193 152 114	55
193 152 115	55
193 152 116	55
193 152 117	55
193 152 124	55
193 152 125	55
193 152 126	55
193 152 127	55
193 152 134	56
193 152 135	56
193 152 136	56
193 152 137	56
193 152 144	56
193 152 145	56
193 152 146	56
193 152 147	56
193 152 154	56
193 152 155	56
193 152 156	56
193 152 157	56
193 152 234	53
193 152 237	53
193 152 244	53

Code	Page
193 152 247	53
193 152 254	53
193 152 257	53
193 152 264	53
193 152 267	53
193 152 274	53
193 152 277	53
193 152 284	53
193 152 287	53
193 152 294	53
193 152 297	53
193 152 304	53
193 152 307	53
193 152 314	53
193 152 317	53
193 152 324	53
193 152 327	53
193 152 334	54
193 152 337	54
193 152 344	54
193 152 347	54
193 152 354	54
193 152 357	54
193 154 034	58
193 154 035	58
193 154 036	58
193 154 037	58
193 154 044	58
193 154 045	58
193 154 046	58
193 154 047	58
193 154 054	58
193 154 055	58
193 154 056	58
193 154 057	58
193 154 064	58
193 154 065	58
193 154 066	58
193 154 067	58
193 154 074	58
193 154 075	58
193 154 076	58
193 154 077	58
193 154 084	58
193 154 085	58
193 154 086	58
193 154 087	58
193 154 094	58
193 154 095	58
193 154 096	58
193 154 097	58
193 154 104	58
193 154 105	58
193 154 106	58
193 154 107	58
193 154 114	58
193 154 115	58
193 154 116	58
193 154 117	58
193 154 124	58
193 154 125	58
193 154 126	58
193 154 127	58
193 154 134	59
193 154 135	59
193 154 136	59
193 154 137	59

Code	Page
193 154 144	59
193 154 145	59
193 154 146	59
193 154 147	59
193 154 154	59
193 154 155	59
193 154 156	59
193 154 157	59
193 154 234	56
193 154 237	56
193 154 244	56
193 154 247	56
193 154 254	56
193 154 257	56
193 154 264	56
193 154 267	56
193 154 274	56
193 154 277	56
193 154 284	56
193 154 287	56
193 154 294	56
193 154 297	56
193 154 304	56
193 154 307	56
193 154 314	56
193 154 317	56
193 154 324	56
193 154 327	56
193 154 334	57
193 154 337	57
193 154 344	57
193 154 347	57
193 154 354	57
193 154 357	57
193 280 153	31
193 280 154	31
193 280 184	29
193 280 185	29
193 280 272	33
193 280 273	33
193 280 274	33
193 280 279	33
193 280 294	33
193 280 300	30
193 280 301	30
193 280 358	29
193 280 359	29
193 280 360	29
193 280 410	31
193 280 680	31
193 280 711	29
193 280 880	27
193 280 881	27
193 280 950	18
193 280 951	18
193 280 952	18
193 280 953	18
193 280 954	18
193 280 958	18
193 280 959	18
193 280 961	16
193 280 963	16
193 280 965	16
193 280 969	16
193 280 992	18
193 280 993	18
193 280 994	18

Index

Code	Page
193 280 995	18
193 280 996	18
193 280 997	17
193 280 998	16
193 280 999	16
193 281 004	16
193 281 005	16
193 281 006	17
193 281 007	17
193 281 008	17
193 281 009	17
193 281 010	17
193 281 011	17
193 281 012	17
193 281 013	17
193 281 027	27
193 281 030	17
193 281 031	17
193 281 032	16
193 281 033	16
193 281 046	31
193 281 047	31
193 281 048	30
193 281 049	30
193 281 052	30
193 281 053	30
193 281 054	29
193 281 055	29
193 281 058	32
193 281 059	32
193 281 060	32
193 281 061	32
193 281 102	104
193 281 103	104
193 281 105	104
193 281 113	45
193 281 122	51
193 281 130	32
193 281 131	32
193 281 147	104
193 281 148	104
193 281 152	45
193 281 154	51
193 281 155	51
193 281 156	51
193 281 157	51
193 281 158	51
193 281 159	51
193 281 160	51
193 281 161	51
193 281 162	51
193 281 163	51
193 281 164	51
193 281 177	32
193 281 178	32
193 281 200	102
193 281 201	102
193 281 202	102
193 281 204	103
193 281 205	103
193 281 207	103
193 281 208	103
193 281 214	103
193 281 215	103
193 281 217	103
193 281 218	103
193 281 250	31

Code	Page
193 281 300	102
193 281 301	102
193 281 302	102
193 281 435	51
193 281 437	51
193 281 438	51
193 281 439	51
193 281 459	43
193 281 558	31
193 301 008	67
193 301 011	67
193 301 016	67
193 301 017	67
193 301 018	67
193 301 019	67
193 301 020	67
193 301 021	67
193 301 028	68
193 301 031	68
193 301 037	68
193 301 038	68
193 301 039	68
193 301 040	68
193 301 100	69
193 301 101	69
193 301 102	69
193 301 103	69
193 301 104	69
193 301 105	69
193 301 106	69
700 627 581	151
700 627 582	151
700 627 658	151
700 627 659	151
700 627 660	151
700 627 661	151
700 627 662	151
700 627 663	151
700 627 664	152
700 627 665	152
700 627 666	152
700 627 667	152
700 627 668	152
700 627 669	152
700 627 670	152
700 627 671	152
700 627 672	152
700 627 673	152
700 627 674	152
700 627 675	152
700 627 676	152
700 627 677	152
700 627 678	152
700 627 679	153
700 627 680	153
700 627 681	153
700 627 682	153
700 627 683	153
700 627 684	153
700 627 685	153
700 627 686	153
700 627 687	153
700 627 688	153
700 627 689	153
700 627 690	153
700 627 691	153
700 627 692	154

Code	Page
700 627 693	154
700 627 694	154
700 627 695	154
700 627 696	154
700 627 697	154
700 627 698	154
700 627 699	154
700 627 700	154
700 627 701	154
700 627 702	154
700 627 703	154
700 627 704	155
700 627 705	155
700 627 706	155
700 627 707	155
700 627 708	155
700 627 709	155
700 627 710	154
700 627 711	154
700 627 712	154
700 627 713	154
700 627 714	154
700 627 715	138
700 627 716	138
700 627 717	138
700 627 718	138
700 627 719	138
700 627 720	138
700 627 721	138
700 627 722	138
700 627 723	138
700 627 724	138
700 627 725	138
700 627 726	138
700 627 727	138
700 627 728	138
700 627 729	138
700 627 730	138
700 627 731	138
700 627 732	138
700 627 733	138
700 627 734	138
700 627 735	138
700 627 736	138
700 627 737	138
700 627 738	138
700 627 739	138
700 627 740	138
700 627 741	138
700 627 742	138
700 627 743	138
700 627 744	138
700 627 745	138
700 627 746	138
700 627 747	138
700 627 748	140
700 627 749	140
700 627 750	140
700 627 751	140
700 627 752	140
700 627 753	140
700 627 754	140
700 627 755	140
700 627 756	140
700 627 757	140
700 627 758	140
700 627 759	140

Index

Code	Page
700 627 760	140
700 627 761	140
700 627 762	140
700 627 763	140
700 627 764	140
700 627 765	140
700 627 766	140
700 627 767	140
700 627 768	140
700 627 769	140
700 627 770	140
700 627 771	140
700 627 772	140
700 627 773	140
700 627 774	140
700 627 775	140
700 627 776	140
700 627 777	140
700 627 778	140
700 627 779	140
700 627 780	140
700 627 781	139
700 627 782	139
700 627 783	139
700 627 784	139
700 627 785	139
700 627 786	139
700 627 787	139
700 627 788	139
700 627 789	139
700 627 790	139
700 627 791	141
700 627 792	141
700 627 793	141
700 627 794	141
700 627 795	141
700 627 796	141
700 627 797	141
700 627 798	141
700 627 799	141
700 627 800	141
700 627 850	155
700 627 853	151
700 627 854	152
700 627 855	152
700 627 856	152
700 627 857	152
700 627 858	152
700 627 859	152
700 627 860	152
700 627 861	152
700 627 862	152
700 627 863	152
700 627 864	152
700 627 865	152
700 627 866	152
700 627 867	152
700 627 868	153
700 627 869	153
700 627 870	153
700 627 871	153
700 627 872	153
700 627 873	153
700 627 874	153
700 627 875	153
700 627 876	153
700 627 877	153

Code	Page
700 627 878	153
700 627 879	153
700 627 880	153
700 627 881	153
700 627 882	153
700 627 883	153
700 627 884	153
700 627 885	154
700 627 886	154
700 627 887	154
700 627 888	154
700 627 889	154
700 627 890	154
700 627 891	154
700 627 892	154
700 627 893	154
700 627 894	154
700 627 895	154
700 627 896	154
700 627 897	154
700 627 898	154
700 627 899	154
700 627 901	154
700 627 902	154
700 627 903	154
700 627 904	154
700 627 905	155
700 627 906	155
700 627 907	155
700 627 908	155
700 627 909	155
700 627 910	155
700 627 911	155
700 627 912	155
700 627 913	155
700 627 914	155
700 627 915	155
700 627 916	151
700 627 917	151
700 627 918	151
700 627 919	151
700 627 920	151
700 627 921	151
700 627 922	151
700 627 923	151
700 627 924	151
700 627 925	151
700 627 926	151
700 627 927	151
700 627 928	151
700 627 929	151
700 627 930	151
700 627 931	151
700 627 932	151
700 627 933	151
700 627 934	151
700 627 935	151
700 627 936	151
700 627 937	151
700 627 938	151
700 627 939	151
700 627 940	151
700 627 941	151
700 627 942	151
700 627 943	152
700 627 944	152
700 627 945	152

Code	Page
700 627 946	152
700 627 947	153
700 627 948	153
700 627 949	153
700 627 950	153
700 627 951	153
700 627 952	153
700 627 953	153
700 627 954	153
700 627 955	152
700 627 956	152
700 627 957	153
700 627 958	153
700 627 959	154
700 627 960	151
700 627 961	151
700 627 976	151
700 627 977	155
701 473 803	37
701 473 804	37
701 473 805	37
701 473 806	37
701 473 807	37
701 473 808	37
701 473 809	37
701 473 810	37
701 473 811	37
701 473 812	37
701 473 813	37
701 473 814	37
701 474 382	106
701 474 383	107
701 474 386	106
701 474 387	106
701 474 388	107
701 474 390	106
701 474 391	106
701 474 392	106
701 474 393	106
701 474 394	106
701 474 395	106
701 474 396	106
701 474 397	106
701 474 398	106
701 474 399	107
701 474 400	107
701 474 401	107
701 480 475	106
701 480 476	106
701 480 477	106
701 480 478	106
701 480 479	106
701 480 480	106
701 480 481	106
701 480 482	106
701 480 483	106
701 480 492	107
701 480 493	107
701 480 494	107
701 485 560	36
701 485 561	36
701 485 562	36
701 485 563	36
701 485 564	36
701 485 565	36
720 100 007	23
720 100 008	23

Index

Code	Page
720 100 009	23
720 100 010	23
720 100 011	23
720 100 017	23
720 100 018	23
720 100 019	23
720 100 020	23
720 100 021	23
720 100 028	23
720 100 029	23
720 100 030	23
720 100 031	23
720 100 040	23
720 100 041	23
720 100 051	23
720 100 206	120
720 100 207	120
720 100 258	21
720 100 259	21
720 100 260	21
720 100 261	21
720 100 281	21
720 100 282	21
720 100 283	21
720 100 756	21
720 100 757	21
720 100 758	21
720 100 759	21
720 100 760	21
720 100 761	21
720 100 766	21
720 100 767	21
720 100 771	21
720 100 772	21
720 100 776	21
720 100 777	21
720 100 782	21
720 100 783	21
720 150 008	24
720 150 009	24
720 150 010	24
720 150 011	24
720 150 018	24
720 150 019	24
720 150 020	24
720 150 021	24
720 150 028	24
720 150 029	24
720 150 030	24
720 150 031	24
720 150 040	24
720 150 041	24
720 150 051	24
720 150 258	22
720 150 259	22
720 150 260	22
720 150 261	22
720 150 281	22
720 150 282	22
720 150 283	22
720 150 758	22
720 150 759	22
720 150 760	22
720 150 761	22
720 150 766	22
720 150 767	22
720 150 771	22

Code	Page
720 150 772	22
720 150 776	22
720 150 777	22
720 150 782	22
720 150 783	22
720 910 007	23
720 910 008	23
720 910 009	23
720 910 010	23
720 910 011	23
720 910 017	23
720 910 018	23
720 910 019	23
720 910 020	23
720 910 021	23
720 910 028	23
720 910 029	23
720 910 030	23
720 910 031	23
720 910 040	23
720 910 041	23
720 910 051	23
720 920 007	35
720 920 008	35
720 920 009	35
720 920 010	35
720 920 011	35
720 920 017	35
720 920 018	35
720 920 019	35
720 920 020	35
720 920 021	35
720 920 028	35
720 920 029	35
720 920 030	35
720 920 031	35
720 920 040	35
720 920 041	35
720 920 051	35
720 920 208	34
720 920 209	34
720 920 210	34
720 920 211	34
720 920 221	34
720 920 231	34
720 920 241	34
720 920 258	20
720 920 259	20
720 920 260	20
720 920 261	20
720 920 281	20
720 920 282	20
720 920 283	20
720 920 706	34
720 920 707	34
720 920 708	34
720 920 709	34
720 920 710	34
720 920 711	34
720 920 718	34
720 920 719	34
720 920 720	34
720 920 721	34
720 920 728	34
720 920 729	34
720 920 730	34
720 920 731	34

Code	Page
720 920 754	20
720 920 756	20
720 920 757	20
720 920 758	20
720 920 759	20
720 920 760	20
720 920 761	20
720 920 763	20
720 920 764	20
720 920 765	20
720 920 766	20
720 920 767	20
720 920 768	20
720 920 771	20
720 920 772	20
720 920 773	20
720 920 776	20
720 920 777	20
720 920 778	20
720 920 781	20
720 920 782	20
720 920 783	20
724 100 256	25
724 100 257	25
724 100 258	25
724 100 259	25
724 100 260	25
724 100 261	25
724 100 756	25
724 100 757	25
724 100 758	25
724 100 759	25
724 100 760	25
724 100 761	25
724 100 771	25
724 100 772	25
724 700 319	106
724 700 320	106
724 700 321	106
724 700 322	106
724 700 323	106
724 700 324	106
724 700 325	106
724 700 424	105
724 700 425	105
724 700 426	105
724 700 427	105
724 700 428	105
724 700 429	105
724 920 206	35
724 920 207	35
724 920 208	35
724 920 209	35
724 920 210	35
724 920 211	35
724 920 256	25
724 920 257	25
724 920 258	25
724 920 259	25
724 920 260	25
724 920 261	25
724 920 706	35
724 920 707	35
724 920 708	35
724 920 709	35
724 920 710	35
724 920 711	35

Index

Code	Page
724 920 718	35
724 920 719	35
724 920 721	35
724 920 756	24
724 920 757	24
724 920 758	24
724 920 759	24
724 920 760	24
724 920 761	24
724 920 767	24
724 920 771	24
724 920 772	24
727 106 305	120
727 106 306	120
727 106 307	120
727 106 308	120
727 106 309	120
727 106 310	120
727 106 311	120
727 106 312	120
727 106 313	120
727 106 314	120
727 116 306	121
727 116 307	121
727 116 308	121
727 116 309	121
727 116 310	121
727 116 311	121
727 116 312	121
727 116 313	121
727 116 314	121
727 116 318	121
727 116 319	121
727 116 320	121
727 116 321	121
727 116 329	121
727 116 330	121
727 116 333	121
727 116 336	121
727 116 337	121
727 116 340	121
727 116 341	121
727 116 342	121
727 116 345	121
727 116 346	121
727 116 347	121
727 116 351	121
727 126 306	123
727 126 307	123
727 126 308	123
727 126 309	123
727 126 310	123
727 126 311	123
727 126 312	123
727 126 313	123
727 126 314	123
727 126 316	123
727 126 317	123
727 126 329	123
727 126 330	123
727 126 333	123
727 126 336	123
727 126 337	123
727 126 338	123
727 126 339	123
727 126 344	123
727 126 345	123

Code	Page
727 126 352	123
727 126 506	127
727 126 507	127
727 126 508	127
727 126 509	127
727 126 510	127
727 126 511	127
727 126 512	127
727 126 513	127
727 126 514	127
727 126 515	123
727 156 306	123
727 156 307	123
727 156 308	123
727 156 309	123
727 156 310	123
727 156 311	123
727 166 306	124
727 166 307	124
727 166 308	124
727 166 309	124
727 166 310	124
727 166 311	124
727 206 305	117
727 206 306	117
727 206 307	117
727 206 308	117
727 206 309	117
727 206 310	117
727 206 311	117
727 206 312	117
727 206 313	117
727 206 314	117
727 206 334	119
727 206 335	119
727 206 337	119
727 206 338	119
727 206 341	119
727 206 346	119
727 206 352	119
727 206 353	119
727 206 357	119
727 206 358	119
727 206 364	119
727 206 366	119
727 206 367	119
727 216 306	118
727 216 307	118
727 216 308	118
727 216 309	118
727 216 310	118
727 216 311	118
727 216 312	118
727 216 313	118
727 216 314	118
727 216 329	118
727 216 330	118
727 216 333	118
727 216 336	118
727 216 337	118
727 216 340	118
727 216 341	118
727 216 342	118
727 216 345	118
727 216 346	118
727 216 347	118
727 216 351	118

Code	Page
727 216 352	118
727 216 353	118
727 216 358	118
727 216 359	118
727 226 306	122
727 226 307	122
727 226 308	122
727 226 309	122
727 226 310	122
727 226 311	122
727 226 329	122
727 226 330	122
727 226 333	122
727 226 336	122
727 226 337	122
727 226 341	122
727 226 347	122
727 226 349	122
727 226 354	122
727 226 355	122
727 226 357	122
727 226 358	122
727 226 359	122
727 226 361	122
727 627 001	144
727 627 011	144
727 627 012	144
727 627 021	144
727 627 022	144
727 627 023	144
727 627 031	144
727 627 032	144
727 627 033	144
727 627 041	144
727 627 042	144
727 627 043	144
727 627 044	144
727 627 051	144
727 627 052	144
727 627 053	144
727 627 054	144
727 627 055	144
727 627 061	144
727 627 062	144
727 627 063	144
727 627 064	144
727 627 065	144
727 627 066	144
727 627 071	144
727 627 072	144
727 627 073	144
727 627 074	144
727 627 075	144
727 627 076	144
727 627 081	144
727 627 082	144
727 627 083	144
727 627 084	144
727 627 085	144
727 627 086	144
727 627 087	144
727 627 091	144
727 627 092	144
727 627 093	144
727 627 094	144
727 627 095	144
727 627 096	144

Index

Code	Page
727 627 097	144
727 627 098	144
727 627 101	145
727 627 102	145
727 627 103	145
727 627 104	145
727 627 105	145
727 627 106	145
727 627 107	145
727 627 108	145
727 627 111	145
727 627 112	145
727 627 113	145
727 627 114	145
727 627 115	145
727 627 116	145
727 627 117	145
727 627 118	145
727 627 123	145
727 627 124	145
727 627 125	145
727 627 126	145
727 627 127	145
727 627 128	145
727 627 135	145
727 627 136	145
727 627 137	145
727 627 138	145
727 627 145	145
727 627 146	145
727 627 147	145
727 627 148	145
727 627 156	145
727 627 157	145
727 627 158	145
727 627 166	145
727 627 167	145
727 627 168	145
727 627 176	145
727 627 177	145
727 627 178	145
727 696 406	132
727 696 407	132
727 696 408	132
727 696 409	132
727 696 410	132
727 696 411	132
727 696 412	132
727 696 413	132
727 696 414	132
727 700 206	105
727 700 207	105
727 700 208	105
727 700 209	105
727 700 210	105
727 700 211	105
727 700 212	105
727 700 313	105
727 700 314	105
727 700 315	105
727 700 316	105
727 700 317	105
727 700 318	105
727 700 319	105
727 700 320	105
727 700 321	105
727 700 322	105

Code	Page
727 700 323	105
727 700 324	105
727 700 325	105
727 706 311	114
727 706 312	114
727 706 313	114
727 706 314	114
727 706 350	114
727 706 351	114
727 706 357	114
727 706 363	114
727 706 369	114
727 816 400	132
727 816 401	132
727 816 402	132
727 816 405	132
727 816 406	132
727 816 407	132
727 816 408	132
727 816 409	132
727 816 410	132
727 816 411	132
727 826 400	129
727 826 401	129
727 826 402	129
727 826 405	131
727 826 406	131
727 826 407	131
727 826 408	131
727 826 409	131
727 826 410	131
727 826 411	131
727 826 415	129
727 826 416	129
727 826 417	129
727 826 418	129
727 826 419	129
727 826 420	129
727 826 421	131
727 826 422	131
727 826 423	131
727 826 430	129
727 826 431	129
727 826 432	129
727 826 433	129
727 826 434	129
727 826 435	129
727 826 436	129
727 826 437	129
727 826 438	129
727 826 439	129
727 826 440	129
727 826 441	129
727 826 442	129
727 826 506	129
727 826 507	129
727 826 508	129
727 826 509	129
727 826 510	129
727 826 511	129
727 826 512	129
727 826 513	129
727 826 514	129
727 906 305	116
727 906 306	116
727 906 307	116
727 906 308	116

Code	Page
727 906 309	116
727 906 310	116
727 906 311	116
727 906 312	116
727 906 313	116
727 906 314	116
727 906 334	117
727 906 335	117
727 906 337	117
727 906 340	117
727 906 341	117
727 906 346	117
727 906 347	117
727 906 352	117
727 906 353	117
727 906 356	117
727 906 357	117
727 906 358	117
727 906 363	117
727 906 364	117
727 906 370	117
727 906 371	117
727 906 376	117
727 916 306	115
727 916 307	115
727 916 308	115
727 916 309	115
727 916 310	115
727 916 311	115
727 916 312	115
727 916 313	115
727 916 314	115
727 916 329	115
727 916 330	115
727 916 333	115
727 916 336	115
727 916 337	115
727 916 340	115
727 916 341	115
727 916 345	115
727 916 346	115
727 916 351	115
727 916 352	115
727 916 353	115
727 916 358	115
727 916 364	115
727 916 371	115
727 916 372	115
727 916 376	115
727 916 506	126
727 916 507	126
727 916 509	126
727 916 512	126
727 916 513	126
727 916 514	126
727 926 306	114
727 926 307	114
727 926 308	114
727 926 309	114
727 926 310	114
727 926 311	114
727 926 312	114
727 926 313	114
727 926 314	114
727 926 329	114
727 926 330	114
727 926 332	114

Index

Code	Page
727 926 333	114
727 926 336	114
727 926 337	114
727 926 339	114
727 926 340	114
727 926 341	114
727 926 345	114
727 926 346	114
727 926 347	114
727 926 351	114
727 926 352	114
727 926 353	114
727 926 357	114
727 926 358	114
727 926 363	114
727 926 364	114
727 926 369	114
727 926 371	114
727 926 372	114
727 926 376	114
727 926 506	125
727 926 507	125
727 926 508	125
727 926 509	125
727 926 510	125
727 926 511	125
727 926 512	125
727 926 513	125
727 926 514	125
727 926 515	125
727 926 516	125
727 926 517	125
727 936 306	116
727 936 307	116
727 936 308	116
727 936 309	116
727 936 310	116
727 936 311	116
727 936 312	116
727 936 313	116
727 936 314	116
727 966 305	124
727 966 306	124
727 966 307	124
727 966 308	124
727 966 309	124
727 966 310	124
727 966 311	124
727 966 312	124
727 966 313	124
727 966 314	124
745 416 400	131
745 416 401	131
745 416 402	131
745 416 405	131
745 416 406	131
745 416 407	131
745 416 408	131
745 416 409	131
745 416 410	131
745 416 411	131
745 440 706	109
745 440 707	109
745 440 708	109
745 440 709	109
745 440 710	109
745 440 711	109
745 440 712	109

Code	Page
745 440 712	109
745 440 713	109
745 440 714	109
745 440 715	109
745 440 716	109
745 440 717	109
745 440 719	109
745 440 720	109
745 440 721	109
745 440 722	109
745 440 723	109
745 440 724	109
745 440 725	109
745 440 726	109
745 440 727	109
745 440 728	109
745 440 729	109
748 400 305	108
748 400 306	108
748 400 307	108
748 400 308	108
748 400 309	108
748 400 310	108
748 400 311	108
748 400 312	108
748 400 313	108
748 400 314	108
748 400 315	108
748 400 316	108
748 400 317	108
748 400 319	108
748 400 320	108
748 400 321	108
748 400 322	108
748 400 323	108
748 440 705	110
748 440 706	110
748 440 707	110
748 440 708	110
748 440 709	110
748 440 710	110
748 440 711	110
748 440 712	110
748 440 713	110
748 440 714	110
748 440 715	110
748 440 716	110
748 440 717	110
748 440 719	110
748 440 720	110
748 440 721	110
748 440 722	110
748 440 723	110
748 440 724	110
748 440 725	110
748 440 726	110
748 440 727	110
748 440 728	110
748 440 729	110
749 440 705	110
749 440 706	110
749 440 707	110
749 440 708	110
749 440 709	110
749 440 710	110
749 440 711	110
749 440 712	110

Code	Page
749 440 713	110
749 440 714	110
749 440 715	110
749 440 716	110
749 440 717	110
749 440 719	110
749 440 720	110
749 440 721	110
749 440 722	110
749 440 723	110
749 440 724	110
749 440 725	110
749 440 726	110
749 440 727	110
749 440 728	110
749 440 729	110
753 000 813	75
753 000 814	75
753 000 815	75
753 000 816	75
753 000 817	75
753 000 818	75
753 000 819	75
753 000 820	75
753 000 821	75
753 000 822	75
753 000 823	75
753 000 824	75
753 000 825	75
753 000 826	75
753 000 827	75
753 000 828	75
753 000 829	75
753 001 006	75
753 001 007	75
753 001 008	75
753 001 009	75
753 001 010	75
753 001 011	75
753 001 012	75
753 001 013	75
753 001 014	75
753 001 015	75
753 001 016	75
753 001 017	75
753 001 018	75
753 001 019	75
753 001 020	75
753 001 021	75
753 001 022	75
753 001 023	75
753 001 024	75
753 001 025	75
753 001 026	75
753 001 027	75
753 001 028	75
753 001 029	75
753 020 821	93
753 020 822	93
753 020 823	93
753 020 824	93
753 020 825	93
753 020 826	93
753 020 827	93
753 021 021	93
753 021 022	93
753 021 023	93

Index

Code	Page
753 021 024	93
753 021 025	93
753 021 026	93
753 021 027	93
753 050 813	77
753 050 814	77
753 050 815	77
753 050 816	77
753 050 817	77
753 050 818	77
753 050 819	77
753 050 820	77
753 050 821	77
753 050 822	77
753 050 823	77
753 050 824	77
753 050 825	77
753 050 826	77
753 050 827	77
753 050 828	77
753 050 829	77
753 051 008	77
753 051 009	77
753 051 010	77
753 051 011	77
753 051 012	77
753 051 013	77
753 051 014	77
753 051 015	77
753 051 016	77
753 051 017	77
753 051 018	77
753 051 019	77
753 051 020	77
753 051 021	77
753 051 022	77
753 051 023	77
753 051 024	77
753 051 025	77
753 051 026	77
753 051 027	77
753 051 028	77
753 051 029	77
753 060 813	78
753 060 814	78
753 060 815	78
753 060 816	78
753 060 817	78
753 060 818	78
753 060 819	78
753 060 820	78
753 060 821	78
753 060 822	78
753 060 823	78
753 060 824	78
753 060 825	78
753 060 826	78
753 060 827	78
753 060 828	78
753 060 829	78
753 061 008	78
753 061 009	78
753 061 010	78
753 061 011	78
753 061 012	78
753 061 013	78
753 061 014	78

Code	Page
753 061 015	78
753 061 016	78
753 061 017	78
753 061 018	78
753 061 019	78
753 061 020	78
753 061 021	78
753 061 022	78
753 061 023	78
753 061 024	78
753 061 025	78
753 061 026	78
753 061 027	78
753 061 028	78
753 061 029	78
753 070 813	76
753 070 814	76
753 070 815	76
753 070 816	76
753 070 817	76
753 070 818	76
753 070 819	76
753 070 820	76
753 070 821	76
753 070 822	76
753 070 823	76
753 070 824	76
753 070 825	76
753 070 826	76
753 070 827	76
753 070 828	76
753 070 829	76
753 071 008	76
753 071 009	76
753 071 010	76
753 071 011	76
753 071 012	76
753 071 013	76
753 071 014	76
753 071 015	76
753 071 016	76
753 071 017	76
753 071 018	76
753 071 019	76
753 071 020	76
753 071 021	76
753 071 022	76
753 071 023	76
753 071 024	76
753 071 025	76
753 071 026	76
753 071 027	76
753 071 028	76
753 071 029	76
753 080 813	79
753 080 814	79
753 080 815	79
753 080 816	79
753 080 817	79
753 080 818	79
753 080 819	79
753 080 820	79
753 080 821	79
753 080 822	79
753 080 823	79
753 080 824	79
753 080 825	79

Code	Page
753 080 826	79
753 080 827	79
753 080 828	79
753 080 829	79
753 081 008	79
753 081 009	79
753 081 010	79
753 081 011	79
753 081 012	79
753 081 013	79
753 081 014	79
753 081 015	79
753 081 016	79
753 081 017	79
753 081 018	79
753 081 019	79
753 081 020	79
753 081 021	79
753 081 022	79
753 081 023	79
753 081 024	79
753 081 025	79
753 081 026	79
753 081 027	79
753 081 028	79
753 081 029	79
753 090 813	80
753 090 814	80
753 090 815	80
753 090 816	80
753 090 817	80
753 090 818	80
753 090 819	80
753 090 820	80
753 090 821	80
753 090 822	80
753 090 823	80
753 090 824	80
753 090 825	80
753 090 826	80
753 090 827	80
753 090 828	80
753 090 829	80
753 091 008	80
753 091 009	80
753 091 010	80
753 091 011	80
753 091 012	80
753 091 013	80
753 091 014	80
753 091 015	80
753 091 016	80
753 091 017	80
753 091 018	80
753 091 019	80
753 091 020	80
753 091 021	80
753 091 022	80
753 091 023	80
753 091 024	80
753 091 025	80
753 091 026	80
753 091 027	80
753 091 028	80
753 091 029	80
753 100 813	71
753 100 814	71

Index

Code	Page
753 100 815	71
753 100 816	71
753 100 817	71
753 100 818	71
753 100 819	71
753 100 820	71
753 100 821	71
753 100 822	71
753 100 823	71
753 100 922	71
753 100 923	71
753 101 001	71
753 101 006	71
753 101 007	71
753 101 008	71
753 101 009	71
753 101 010	71
753 101 011	71
753 101 012	71
753 101 013	71
753 101 014	71
753 101 015	71
753 101 016	71
753 101 017	71
753 101 018	71
753 101 019	71
753 101 020	71
753 101 606	13
753 101 607	13
753 101 608	13
753 101 609	13
753 101 610	13
753 101 611	13
753 101 812	13
753 101 813	13
753 101 814	13
753 101 815	13
753 101 817	13
753 101 818	13
753 101 819	13
753 101 820	13
753 101 821	13
753 120 813	73
753 120 814	73
753 120 815	73
753 120 816	73
753 120 817	73
753 120 818	73
753 120 819	73
753 120 820	73
753 120 821	73
753 120 822	73
753 120 823	73
753 120 908	73
753 120 909	73
753 120 910	73
753 120 911	73
753 120 912	73
753 120 913	73
753 120 914	73
753 120 915	73
753 120 916	73
753 120 917	73
753 120 918	73
753 120 919	73
753 120 920	73
753 120 921	73

Code	Page
753 120 922	73
753 120 923	73
753 140 813	74
753 140 814	74
753 140 815	74
753 140 816	74
753 140 817	74
753 140 818	74
753 140 819	74
753 140 820	74
753 140 821	74
753 140 822	74
753 140 823	74
753 141 008	74
753 141 009	74
753 141 010	74
753 141 011	74
753 141 012	74
753 141 013	74
753 141 014	74
753 141 015	74
753 141 016	74
753 141 017	74
753 141 018	74
753 141 019	74
753 141 020	74
753 141 021	74
753 141 022	74
753 141 023	74
753 150 813	72
753 150 814	72
753 150 815	72
753 150 816	72
753 150 817	72
753 150 818	72
753 150 819	72
753 150 820	72
753 150 821	72
753 150 822	72
753 150 823	72
753 150 922	72
753 150 923	72
753 151 006	72
753 151 007	72
753 151 008	72
753 151 009	72
753 151 010	72
753 151 011	72
753 151 012	72
753 151 013	72
753 151 014	72
753 151 015	72
753 151 016	72
753 151 017	72
753 151 018	72
753 151 019	72
753 151 020	72
753 151 021	72
753 151 608	14
753 151 609	14
753 151 610	14
753 151 611	14
753 151 812	14
753 151 813	14
753 151 814	14
753 151 815	14
753 151 817	14

Code	Page
753 151 818	14
753 151 819	14
753 151 820	14
753 151 821	14
753 200 801	85
753 200 802	81
753 200 803	81
753 200 804	81
753 200 805	81
753 200 806	81
753 200 807	81
753 200 808	81
753 200 809	81
753 200 810	85
753 200 811	85
753 200 812	85
753 200 813	81
753 200 814	81
753 200 815	81
753 200 816	81
753 200 817	81
753 200 818	81
753 200 819	81
753 200 820	81
753 200 821	81
753 200 822	85
753 200 823	85
753 200 824	85
753 200 825	85
753 200 826	85
753 200 827	85
753 200 828	83
753 200 829	83
753 200 830	83
753 200 831	83
753 200 832	83
753 200 833	83
753 200 834	83
753 200 835	83
753 200 836	83
753 200 837	83
753 200 838	83
753 200 839	83
753 200 840	83
753 200 841	83
753 200 842	83
753 200 843	83
753 200 844	83
753 200 845	85
753 200 846	85
753 200 847	85
753 200 848	85
753 200 849	85
753 200 850	85
753 200 851	83
753 200 852	83
753 200 853	83
753 200 854	83
753 200 855	85
753 200 856	85
753 200 857	85
753 200 858	85
753 200 859	85
753 200 860	85
753 200 861	85
753 200 862	85
753 200 863	85

Index

Code	Page
753 200 864	85
753 200 865	85
753 200 866	85
753 200 867	85
753 200 868	85
753 200 869	85
753 200 870	85
753 200 902	81
753 200 903	81
753 200 904	81
753 200 905	81
753 200 906	81
753 200 907	81
753 200 908	81
753 200 909	81
753 201 001	81
753 201 002	84
753 201 003	84
753 201 004	84
753 201 005	84
753 201 006	81
753 201 007	81
753 201 008	81
753 201 009	81
753 201 010	81
753 201 011	81
753 201 012	81
753 201 013	81
753 201 014	81
753 201 015	81
753 201 016	81
753 201 017	81
753 201 018	81
753 201 019	81
753 201 020	81
753 201 027	82
753 201 028	82
753 201 029	82
753 201 030	82
753 201 031	82
753 201 032	82
753 201 033	82
753 201 034	82
753 201 035	82
753 201 036	82
753 201 037	82
753 201 038	82
753 201 039	82
753 201 040	82
753 201 041	82
753 201 042	82
753 201 043	82
753 201 044	82
753 201 045	82
753 201 046	82
753 201 047	82
753 201 048	82
753 201 049	82
753 201 050	82
753 201 051	82
753 201 052	82
753 201 053	82
753 201 054	82
753 201 069	84
753 201 070	84
753 201 072	84
753 201 073	82

Code	Page
753 201 074	82
753 201 075	82
753 201 076	82
753 201 077	84
753 201 078	82
753 201 079	82
753 201 080	84
753 201 081	84
753 201 082	84
753 201 084	84
753 201 085	84
753 201 086	84
753 201 087	84
753 201 089	84
753 201 090	84
753 201 091	84
753 201 092	84
753 201 093	84
753 201 094	84
753 201 095	84
753 201 096	84
753 201 097	84
753 201 098	84
753 201 099	84
753 201 100	84
753 201 101	84
753 201 102	84
753 201 103	84
753 201 104	84
753 201 105	84
753 201 106	84
753 201 107	84
753 201 108	84
753 201 109	84
753 201 110	84
753 201 111	84
753 201 112	84
753 201 113	84
753 201 114	84
753 201 115	84
753 201 116	84
753 201 606	17
753 201 607	17
753 201 608	17
753 201 609	17
753 201 610	17
753 201 611	17
753 201 613	17
753 201 614	17
753 201 615	17
753 201 617	17
753 201 618	17
753 201 812	15
753 201 813	15
753 201 814	15
753 201 815	15
753 201 817	15
753 201 818	15
753 201 819	15
753 201 820	15
753 201 821	15
753 201 827	83
753 201 873	83
753 201 874	83
753 201 875	83
753 201 876	83
753 201 878	83

Code	Page
753 201 879	83
753 211 037	16
753 211 039	16
753 211 040	16
753 211 059	16
753 211 060	16
753 211 063	16
753 211 069	16
753 211 070	16
753 211 073	16
753 211 080	16
753 211 083	16
753 211 606	15
753 211 607	15
753 211 608	15
753 211 609	15
753 211 610	15
753 211 611	15
753 220 821	94
753 220 822	94
753 220 823	94
753 220 824	94
753 220 825	94
753 220 826	94
753 220 827	94
753 220 832	95
753 221 021	94
753 221 022	94
753 221 023	94
753 221 024	94
753 221 025	94
753 221 026	94
753 221 027	94
753 221 031	95
753 221 032	95
753 251 011	86
753 251 012	86
753 251 013	86
753 251 014	86
753 251 063	86
753 251 064	86
753 700 611	107
753 700 612	107
753 700 613	107
753 700 614	107
753 700 615	107
753 700 616	107
753 700 617	107
753 700 618	107
753 700 619	107
753 700 620	107
753 700 621	107
753 700 622	107
753 700 623	107
753 700 624	107
753 700 625	107
753 700 626	107
753 700 627	107
753 700 628	107
753 700 629	107
753 798 826	98
753 798 827	98
753 798 828	98
753 798 829	98
753 798 830	98
753 798 831	98
753 798 832	98

Index

Code	Page
753 798 833	98
753 798 834	98
753 798 851	98
753 798 852	98
753 798 853	98
753 798 854	98
753 798 855	98
753 798 856	98
753 798 857	98
753 798 858	98
753 798 859	98
753 800 006	91
753 800 007	91
753 800 008	91
753 800 009	91
753 800 010	91
753 800 011	91
753 800 012	91
753 800 013	91
753 800 014	91
753 800 015	91
753 800 016	91
753 800 017	91
753 800 018	91
753 800 019	91
753 800 020	91
753 800 021	91
753 800 022	91
753 800 023	91
753 800 024	91
753 800 025	91
753 800 026	91
753 800 027	91
753 800 028	91
753 800 029	91
753 800 085	92
753 800 086	92
753 800 087	92
753 800 088	92
753 800 089	92
753 800 090	92
753 800 091	92
753 800 092	92
753 800 093	92
753 800 094	92
753 800 095	92
753 800 096	92
753 800 097	92
753 800 098	92
753 800 099	92
753 800 100	92
753 800 101	92
753 800 102	92
753 800 103	92
753 800 104	92
753 900 000	96
753 900 001	96
753 900 002	96
753 900 003	96
753 900 004	96
753 900 005	96
753 900 006	96
753 900 007	96
753 900 008	96
753 900 009	96
753 900 010	96
753 900 011	96

Code	Page
753 900 012	96
753 900 013	96
753 900 014	96
753 900 015	96
753 900 016	96
753 900 017	96
753 900 018	96
753 900 019	96
753 900 020	96
753 900 021	96
753 900 022	96
753 900 023	96
753 900 024	96
753 900 025	96
753 900 026	96
753 900 027	96
753 900 800	89
753 900 801	89
753 900 802	89
753 900 803	89
753 900 804	89
753 900 805	89
753 900 806	89
753 900 807	89
753 900 808	89
753 900 809	89
753 900 810	89
753 900 811	89
753 900 812	89
753 900 813	89
753 900 814	89
753 900 815	89
753 900 816	89
753 900 817	89
753 900 818	89
753 900 819	89
753 900 820	89
753 900 821	89
753 900 822	89
753 900 823	89
753 900 824	89
753 900 825	89
753 900 826	89
753 900 827	89
753 900 828	89
753 900 829	89
753 900 831	89
753 900 832	89
753 900 866	89
753 900 867	89
753 900 868	89
753 900 870	89
753 900 872	89
753 900 873	89
753 900 874	89
753 900 875	89
753 900 876	89
753 900 877	89
753 900 880	89
753 900 881	89
753 900 882	89
753 900 884	89
753 900 885	89
753 900 886	89
753 900 887	89
753 900 888	89
753 900 889	89

Code	Page
753 900 890	89
753 900 891	89
753 900 892	89
753 900 893	89
753 900 894	89
753 900 895	89
753 900 896	89
753 900 897	99
753 900 898	89
753 900 899	89
753 900 997	99
753 901 000	87
753 901 001	87
753 901 002	87
753 901 003	87
753 901 004	87
753 901 005	87
753 901 012	87
753 901 013	87
753 901 014	88
753 901 015	88
753 901 016	88
753 901 017	88
753 901 018	88
753 901 019	88
753 901 020	88
753 901 022	88
753 901 024	88
753 901 025	88
753 901 026	88
753 901 027	88
753 901 029	88
753 901 030	88
753 901 032	87
753 901 033	87
753 901 034	87
753 901 038	87
753 901 039	88
753 901 040	88
753 901 041	87
753 901 042	87
753 901 043	88
753 901 044	88
753 901 045	88
753 901 046	87
753 901 047	87
753 901 048	87
753 901 049	88
753 901 050	88
753 901 052	87
753 901 053	87
753 901 054	87
753 901 055	87
753 901 058	87
753 901 059	87
753 901 060	87
753 901 063	87
753 901 064	87
753 901 065	87
753 901 066	87
753 901 067	87
753 901 068	87
753 901 070	87
753 901 071	87
753 901 072	87
753 901 073	87
753 901 074	87

Index

Code	Page
753 901 075	87
753 901 076	87
753 901 077	87
753 901 078	87
753 901 080	87
753 901 081	87
753 901 082	87
753 901 083	87
753 901 084	87
753 901 085	87
753 901 086	87
753 901 087	87
753 901 088	87
753 901 089	87
753 901 090	87
753 901 091	87
753 901 092	87
753 901 094	87
753 901 095	87
753 901 096	87
753 901 097	87
753 901 098	87
753 901 099	87
753 901 605	38
753 901 606	38
753 901 607	38
753 901 612	39
753 901 613	39
753 901 614	39
753 901 639	17
753 901 640	17
753 901 641	17
753 901 644	17
753 901 645	17
753 901 646	17
753 901 651	17
753 901 652	17
753 901 656	17
753 901 657	17
753 901 658	17
753 901 831	18
753 901 833	18
753 901 834	18
753 901 835	18
753 901 836	18
753 901 837	18
753 901 838	18
753 901 840	18
753 901 841	18
753 902 800	97
753 902 801	97
753 902 802	97
753 902 803	97
753 902 804	97
753 902 805	97
753 902 806	97
753 902 807	97
753 902 808	97
753 902 809	97
753 902 810	97
753 902 811	97
753 902 812	97
753 902 813	97
753 902 814	97
753 902 815	97
753 902 816	97
753 902 817	97

Code	Page
753 902 818	97
753 902 819	97
753 902 820	97
753 902 821	97
753 902 822	97
753 902 823	97
753 902 824	97
753 902 825	97
753 902 826	97
753 902 827	97
753 902 828	97
753 902 829	97
753 902 830	97
753 902 831	97
753 902 832	97
753 902 833	97
753 902 834	97
753 911 208	12
753 911 209	12
753 911 210	12
753 911 211	12
753 911 606	11
753 911 607	11
753 911 608	11
753 911 609	11
753 911 610	11
753 911 611	11
753 911 612	11
753 911 613	11
753 911 614	11
753 911 615	11
753 911 616	11
753 911 617	11
753 911 618	11
753 911 619	11
753 911 620	11
753 911 621	11
753 911 622	11
753 911 623	11
753 911 624	11
753 911 625	11
753 911 817	12
753 911 818	12
753 911 819	12
753 911 820	12
753 911 821	12
753 911 822	12
753 911 823	12
753 911 824	12
753 911 825	12
753 911 826	12
753 911 827	12
753 911 828	12
753 911 829	12
753 920 608	38
753 920 609	38
753 920 610	38
753 920 611	38
753 920 708	38
753 920 709	38
753 920 710	38
753 920 711	38
753 920 831	99
753 920 832	99
753 921 031	99
753 930 831	100
753 930 898	100

Code	Page
753 931 031	100
753 931 098	100
753 960 810	90
753 960 811	90
753 960 812	90
753 960 813	90
753 960 814	90
753 960 815	90
753 960 816	90
753 960 817	90
753 960 818	90
753 960 819	90
753 960 820	90
753 960 821	90
753 960 822	90
753 960 823	90
753 960 824	90
753 960 825	90
753 960 826	90
753 960 827	90
753 960 828	90
753 960 829	90
753 960 922	90
753 960 923	90
753 960 924	90
753 960 925	90
753 960 926	90
753 960 927	90
753 960 928	90
753 960 929	90
753 961 006	90
753 961 007	90
753 961 008	90
753 961 009	90
753 961 010	90
753 961 011	90
753 961 012	90
753 961 013	90
753 961 014	90
753 961 015	90
753 961 016	90
753 961 017	90
753 961 018	90
753 961 019	90
753 961 020	90
753 961 021	90
753 961 606	19
753 961 607	19
753 961 608	19
753 961 609	19
753 961 610	19
753 961 611	19
753 961 617	19
753 961 619	19
753 961 620	19
753 961 621	19
753 961 712	19
753 961 713	19
753 961 714	19
753 961 715	19
753 961 716	19
753 961 717	19
753 961 718	19
753 961 719	19
753 961 720	19
775 102 442	159
775 102 452	160

Index

Code	Page
775 102 453	160
775 102 501	159
775 102 502	159
775 102 503	159
775 102 504	159
775 102 505	159
775 102 506	159
775 102 516	159
775 102 520	159
775 102 525	159
775 102 526	159
775 102 531	159
775 102 535	159
775 102 538	159
775 102 540	159
775 102 602	160
775 102 603	160
775 102 604	160
775 102 605	160
775 102 606	160
775 102 613	160
775 102 701	159
775 102 702	159
775 102 703	159
775 102 704	159
775 102 705	159
775 102 706	159
775 106 503	159
775 108 506	159
775 202 201	160
775 202 202	160
775 202 203	160
775 202 204	160
775 202 205	160
775 202 206	160
775 202 442	160
775 202 452	161
775 202 453	161
775 202 454	161
775 202 455	161
775 202 456	161
775 202 602	161
775 202 603	161
775 202 771	161
775 202 772	161
775 202 773	161
775 202 774	161
775 202 775	161
775 202 776	161
775 208 203	160
775 208 205	160
775 208 206	160
775 212 201	161
775 212 202	161
775 212 203	161
775 212 204	161
775 212 205	161
775 212 206	161
775 212 442	161
775 212 452	162
775 212 453	162
775 212 454	162
775 212 455	162
775 212 456	162
775 212 771	162
775 212 772	162
775 212 773	162

Code	Page
775 212 774	162
775 212 775	162
775 212 776	162
775 222 101	160
775 222 102	160
775 222 103	160
775 232 201	161
775 232 202	161
775 232 203	161
775 262 202	160
775 308 226	163
775 312 203	164
775 318 206	164
775 322 102	162
775 322 103	162
775 402 442	162
775 402 453	163
775 402 454	163
775 402 455	163
775 402 456	163
775 402 502	162
775 402 503	162
775 402 504	162
775 402 505	162
775 402 506	162
775 408 506	162
775 412 152	163
775 412 153	163
775 412 752	163
775 452 201	164
775 452 202	164
775 452 203	164
775 452 204	164
775 452 205	164
775 452 206	164
775 452 442	164
775 641 502	36
775 641 507	36
775 641 510	36
775 641 514	36
775 641 518	36
775 641 524	36
775 641 632	36
775 641 636	36
775 641 640	36
775 641 641	36
775 641 645	36
775 641 655	36
775 641 659	36
775 642 664	36
775 642 665	36
775 642 666	36
775 642 669	36
775 642 672	36
775 642 673	36
775 642 675	36
775 642 678	36
775 950 255	164
775 950 256	164
775 950 302	164
775 950 303	164
775 950 354	164
780 888 925	164
780 925 551	164
799 198 097	128
799 198 098	128
799 198 099	128

Code	Page
99905100K	142
99905101K	142
99905102K	142

Consistent and Solution Oriented in Gas and Water Supply



ELGEF Plus

The modularity of this system renders ELGEF Plus a very convincing electrofusion system for Georg Fischer PE pressure piping.



POLY 16 Plus

POLYFAST AZ

POLY 16 Plus and POLYFAST AZ compression fittings from Georg Fischer Alprene – the safe, detachable connection with an active sealing system consisting of thrust ring and double lip gasket.

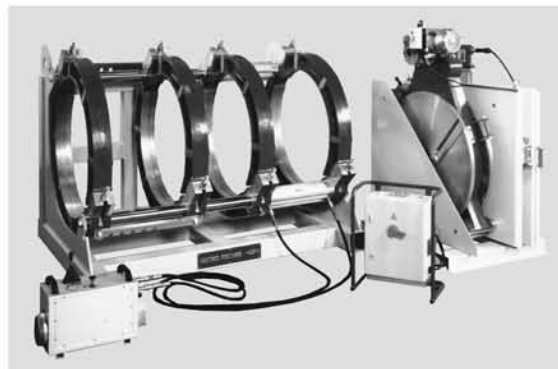

Butt Fusion Machines

Georg Fischer Pipe Jointing Technology provides a comprehensive range of hydraulic-controlled, on-site fusion machines.



MULTI/JOINT

With Georg Fischer WAGA and MULTI/JOINT you always have the right product for a restraint or flexible connection for a variety of pipe materials.



PRIMOFIT

Georg Fischer Castings has a complete range of metal compression fittings on offer. The PRIMOFIT fitting is a robust way of connecting plastic and metal pipes in gas and water supply.

Training

Invest in the training of your employees

Qualified personnel is one of the key factors for the success of a company.

Only skilled employees with the appropriate know-how and customer focus are reliable partners.



GF Piping Systems, as a professional system and solution provider, offers you training courses with a focus on products, applications, sales arguments and different customer requirements.

The jointing technologies, as well as measurement and control technology are increasingly innovative. To stay up-to-date, you need continuing education.

GF Piping Systems contributes essentially to your know-how. No matter what your expert field may be – utilities, building technology or industrial applications – you can benefit from the training courses, which are adapted to the different market segments and applications.

We offer a customised programme for salespersonnel and occupational groups like installers, planners and constructors. Besides the theory, we attach great importance to hands-on practice. Our rooms are especially equipped for practical training. They are suitable for simultaneous training of up to 100 persons under ideal conditions.

For the choice of trainers, we work closely with our sales staff. There are Basic, Advanced and Master Courses covering the full spectrum of issues. More information about our current training program:

<http://www.piping.georgfischer.com>



General Condition of Supply of Georg Fischer Piping Systems Limited, Schaffhausen

1 General

- 1.1 These General Conditions shall apply to all Products supplied by Georg Fischer to the Purchaser. They shall also apply to all future business even when no express reference is made to them.
- 1.2 Any deviating or supplementary conditions especially Purchaser's general conditions of purchase and verbal agreements shall only be applicable if accepted in writing by Georg Fischer.
- 1.3 The written form shall be deemed to be fulfilled by all forms of transmission, evidenced in the form of text, such as telefax, e-mail, etc.

2 Tenders

- Tenders shall only be binding if they contain a specifically stated period for acceptance.

3 Scope of Delivery

- 3.1 Georg Fischer's product range is subject to change.
- 3.2 The confirmation of order shall govern the scope and execution of the contract.

4 Data and Documents

- 4.1 Technical documents such as drawings, descriptions, illustrations and data on dimensions, performance and weight as well as the reference to standards are for information purposes only. They are not warranted characteristics and are subject to change.
- 4.2 All technical documents shall remain the exclusive property of Georg Fischer and may only be used for the agreed purposes or as Georg Fischer may consent.

5 Confidentiality, Protection of Personal Data

- 5.1 Each party shall keep in strict confidence all commercial or technical information relating to the business of the other party, of which it has gained knowledge in the course of its dealing with the other party. Such information shall neither be disclosed to third parties nor used for other purposes than those for which the information has been supplied.
- 5.2 In the context of the contractual relation with the Purchaser personal data may be processed. The Purchaser agrees to the disclosure of said data to third parties such as foreign subcontractors and suppliers etc.

6 Local Laws and Regulations, Export Controls

- 6.1 The Purchaser shall bring to the attention of Georg Fischer all local laws and regulations at the place of destination which bear connection with the execution of the contract and the adherence to relevant safety regulations and approval procedures.
- 6.2 In case of re-exports, Purchaser shall be responsible for compliance with pertinent export control regulations.

7 Price

- 7.1 Unless agreed otherwise, the prices shall be deemed quoted net ex works (according to Incoterms of the ICC, latest version) including standard packing. All supplementary costs such as the cost of carriage, insurance, export-, transit- and importances etc. shall be borne by the Purchaser. The Purchaser shall also bear the costs of all taxes, fees, duties etc. connected with the contract.
- 7.2 If the costs of packing, carriage, insurance, fees and other supplementary costs are included in the tender price or contract price or are referred to specifically in the tender or confirmation of order, Georg Fischer reserve the right to revise their prices accordingly should any change occur in the relevant tariffs.

8 Terms of Payment

- 8.1 The Purchaser shall make payment in the manner agreed by the parties without any deductions such as discounts, costs, taxes or dues.
- 8.2 The Purchaser may only withhold or off-set payments due against counter claims which are either expressly acknowledged by Georg Fischer or finally awarded to the Purchaser. In particular, payment shall still be made when unessential items are still out-standing provided that the Products already delivered are not rendered unusable as a result.

9 Retention of Title

- 9.1 The Products shall remain the property of Georg Fischer until the Purchaser shall have settled all claims, present and future, which Georg Fischer may have against him.
- 9.2 Should the Purchaser resell Products to which title is reserved, in the ordinary course of business, he shall hereby be deemed to have tacitly assigned to Georg Fischer the proceeds deriving from their sale together with all collateral rights, securities and reservations of title until all claims held by Georg Fischer shall have been settled. Until revoked by Georg Fischer, this assignment shall not preclude Purchaser's right to collect the assigned receivables.
- 9.3 To the extent the value of the Products to which title is reserved together with collateral securities exceeds Georg Fischer's claims against the Purchaser by more than 20%, Georg Fischer shall re-assign the above proceeds to Purchaser at his request.

10 Delivery

- 10.1 The term of delivery shall commence as soon as the contract has been entered into, all official formalities such as import and payment permits have been obtained and all essential technical issues have been settled. The term of delivery shall be deemed duly observed when, upon its expiry, the Products are ready for despatch.
- 10.2 Delivery is subject to the following conditions, i.e. the term of delivery shall be reasonably extended:
 - a) if Georg Fischer are not supplied in time with the information necessary for the execution of the contract or if subsequent changes causing delays are made by the Purchaser.
 - b) if Georg Fischer are prevented from performing the contract by force majeure. Force majeure shall equally be deemed to be any unforeseeable event beyond Georg Fischer's control which renders Georg Fischer's performance commercially unpractical or impossible, such as delayed or defective supplies from sub contractors labour disputes, governmental orders or regulations, shortages in materials or energy, serious disturbances in Georg Fischer's works, such as the total or partial destruction of plant and equipment or the breakdown of essential facilities, serious disruptions in transport facilities, e.g. impassable roads.
Should the effect of force majeure exceed a period of six months, either party may cancel the contract forthwith.
Georg Fischer shall not be liable for any damage or loss of any kind whatsoever resulting therefrom, any suspension or cancellation being without prejudice to Georg Fischer's right to recover all sums due in respect of consignments delivered and costs incurred to date.
 - c) if the Purchaser is in delay with the fulfilment of his obligations under the contract, in particular, if he does not adhere to the agreed conditions of payment or if he has failed to timely provide the agreed securities.
- 10.3 If for reasons attributable to Georg Fischer the agreed term of delivery or a reasonable extension thereof is exceeded, Georg Fischer shall not be deemed in default until the Purchaser has granted to Georg Fischer in writing a reasonable extension thereof of not less than one month which equally is not met.
The Purchaser shall then be entitled to the remedies provided at law, it being however understood that, subject to limitations of Art. 16, damage claims shall be limited to max. 10% of the price of the delayed delivery.
- 10.4 Part shipments shall be allowed and Georg Fischer shall be entitled to invoice for such partial deliveries.
- 10.5 If the Purchaser fails to take delivery within a reasonable time of Products notified as ready for despatch, Georg Fischer shall be entitled to store the Products at the Purchaser's expense and risk and to invoice them as delivered. If Purchaser fails to effect payment, Georg Fischer shall be entitled to dispose of the Products.
- 10.6 Should Purchaser cancel an order without justification and should Georg Fischer not insist on the performance of the contract, Georg Fischer shall be entitled to liquidated damages in the amount of 10% of the contract price, Georg Fischer's right to prove and claim higher damages remaining reserved. Purchaser shall be entitled to prove, that Georg Fischer has suffered no or a considerably lower damage.

11 Packing

- If the Products are provided with additional packing over and above the standard packing, such packing shall be charged additionally.

12 Passing of Risk

- 12.1 The risk in the Products shall pass to the Purchaser as soon as they have left Georg Fischer's works (EX WORKS, Incoterms ICC, latest version), even if delivery is made carriage-paid, under similar clauses or including installation or when carriage is organized and managed by Georg Fischer.
- 12.2 If delivery is delayed for reasons beyond Georg Fischer's control, the risk shall pass to the Purchaser when he is notified that the Products are ready for despatch.

13 Carriage and Insurance

- 13.1 Unless agreed otherwise, the Purchaser shall bear the cost of carriage.
- 13.2 The Purchaser shall be responsible for transport insurance against damage of whatever kind. Even when such insurance is arranged by Georg Fischer it shall be deemed taken out by the order of and for the account of the Purchaser and at his risk.
- 13.3 Special requests regarding carriage and insurance shall be communicated to Georg Fischer in due time. Otherwise carriage shall be arranged by Georg Fischer at their discretion, but without responsibility, by the quickest and cheapest method possible.
In case of carriage-paid delivery transport arrangements shall be made by Georg Fischer. If the Purchaser specifies particular requirements, any extra costs involved shall be borne by him.
- 13.4 In the event of damage or loss of the Products during carriage the Purchaser shall mark the delivery documents accordingly and immediately have the damage ascertained by the carrier. Not readily ascertainable damages sustained during carriage shall be notified to the carrier within six days after receipt of the Products.

14 Inspection, Notification of Defects and Damages

- 14.1 The Products will be subject to normal inspection by Georg Fischer during manufacture. Additional tests required by the Purchaser shall be agreed upon in writing and shall be charged to the Purchaser.
- 14.2 It shall be a condition of Georg Fischer's obligation under the warranties stated hereinafter that Georg Fischer be notified in writing by the Purchaser of any purported defect immediately upon discovery. Notice concerning weight, numbers or apparent defects is to be given latest within 30 days from receipt of the Products, notice of other defects immediately latest within 7 working days after discovery, in any event within the agreed warranty period.
- 14.3 Purchaser shall not dispose of allegedly defective Products until all warranty and/or damage claims are finally settled. At its request, defective Products are to be placed at Georg Fischer's disposal.
- 14.4 At its request, Georg Fischer shall be given the opportunity to inspect the defect and/or damage, prior to commencement of remedial work, either itself or by third party experts.

15 Warranty

- 15.1 At the written request of the Purchaser, Georg Fischer undertake to repair or replace at their discretion, as quickly as possible and free of charge all Products supplied which demonstrably suffer from faulty design, materials or workman-ship or from faulty operating or installation instructions.
In order to protect employees from toxic or radioactive substances which may have been transported through defective parts returned to Georg Fischer's sales organisation, said parts must be accompanied by a Material Safety Disclosure Form. The form may be obtained from Georg Fischer's local sales company or via www.piping.georgfischer.com.
Replaced parts shall become property of Georg Fischer.
- 15.2 For Products which are manufactured to specifications, drawings or patterns supplied by the Purchaser, Georg Fischer's warranty shall be restricted to proper materials and workmanship.
- 15.3 The Purchaser shall be entitled to cancel the contract or to demand a reduction in the contract price if also a second attempt to repair or replace the Products has failed.
- 15.4 For Products or essential components manufactured by a third party and supplied by Georg Fischer under this contract, Georg Fischer's warranty is limited to the warranty provided by said third party.
- 15.5 This warranty shall not apply to damage resulting from normal wear and tear, improper storage and maintenance, failure to observe the operating instructions, overstraining or overloading, unsuitable operating media, unsuitable construction work or unsuitable building ground, improper repairs or alterations by the Purchaser or third parties, the use of other than original spare parts and other reasons beyond Georg Fischer's control.
- 15.6 No action or claim may be brought by the Purchaser on account of any alleged breach of warranty or any other obligation of Georg Fischer after the expiration of twelve (12) months from receipt of the Products by the end user or at the latest within eighteen (18) months of the Products being despatched by Georg Fischer.
- 15.7 In case of Products for use in domestic installations or in utilities
 - Georg Fischer will assume the costs of dismantling the defective Product and restoring the damaged object as well as, in case of negligence, all other direct damages caused by the defective Product (damage to property and injury to or death of persons) up to CHF 1 000 000 per occurrence.
 - the statute of limitations for warranty or damage claims - contrary to Section 15.6 - will be 5 years from the date of installation.

16 Limitation of Liability

- All cases of breach of contract and the relevant consequences as well as all rights and claims on the part of the customer, irrespective of what ground they are based, are exhaustively covered by these general conditions of supply. In particular, any claims not expressly mentioned for damages, reduction of price, termination of or withdrawal from the contract are excluded. In no case whatsoever shall the customer be entitled to claim damages other than compensation for costs of remedying defects in the supplies. This in particular refers, but shall not be limited, to loss of production, loss of use, loss of orders, loss of profit and other direct or indirect or consequential damage. This exclusion of liability, however, does not apply to unlawful intent or gross negligence on the part of Georg Fischer and in case of strict liability under applicable product liability statutes, but does apply to unlawful intent or gross negligence of persons employed or appointed by Georg Fischer to perform any of its obligations.

17 Severability

- Should any term or clause of these General Conditions in whole or in part be found to be unenforceable or void, all other provisions shall remain in full force and effect and the unenforceable or void provision shall be replaced by a valid provision, which comes closest to the original intention of the unenforceable or invalid provision.

18 Place of Performance and Jurisdiction

- 18.1 Place of performance for the Products shall be the Georg Fischer works from which the Products are despatched.
- 18.2 Any civil action based upon any alleged breach of this contract shall be filed and prosecuted exclusively in the courts of Schaffhausen, Switzerland.
Georg Fischer however reserves the right to file actions in any court having jurisdiction over controversies arising out of or in connection with the present contract.
- 18.3 The contract shall be governed by Swiss law without regard to conflict of law provisions that would require the application of another law.

GF Piping Systems → worldwide at home

Our sales companies and representatives ensure local customer support in over 100 countries.

www.piping.georgfischer.com

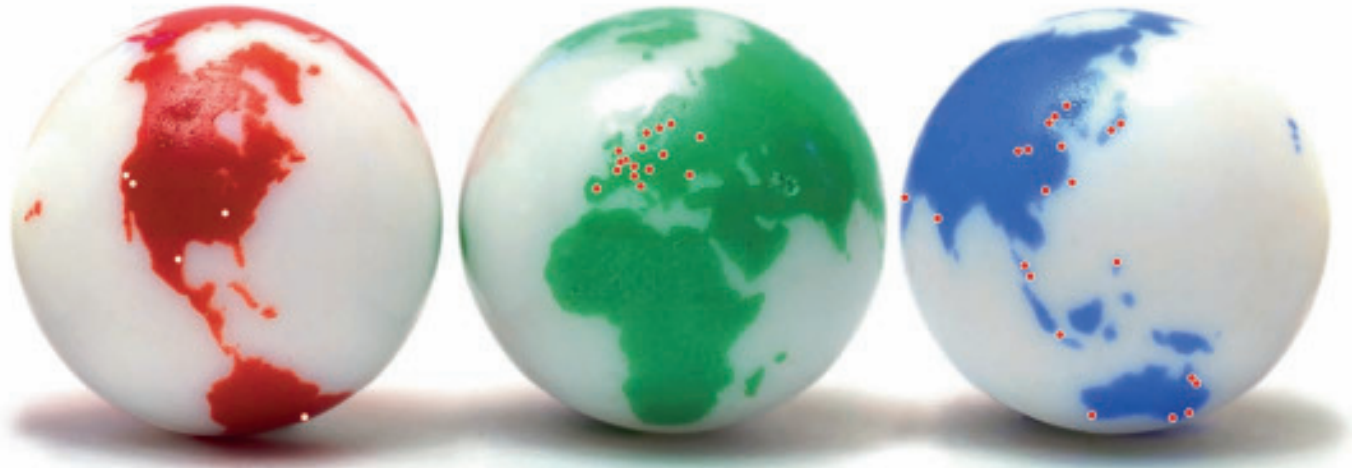

The technical data is not binding. They neither constitute expressly warranted characteristics nor guaranteed properties nor a guaranteed durability. They are subject to modification. Our General Terms of Sale apply.

Adding Quality to People's Lives

Australia George Fischer Pty Ltd Riverwood NSW 2210 Australia Phone +61(0)2 9502 8000 australia.ps@georgfischer.com www.georgfischer.com.au	Denmark/Iceland Georg Fischer A/S 2630 Taastrup Phone +45 (0)70 22 19 75 info.dk.ps@georgfischer.com www.georgfischer.dk	Japan Georg Fischer Ltd 556-0011 Osaka, Phone +81(0)6 6635 2691 jp.ps@georgfischer.com www.georgfischer.jp	Norway Georg Fischer AS 1351 Rud Phone +47(0)67 18 29 00 no.ps@georgfischer.com www.georgfischer.no	Switzerland Georg Fischer Rohrleitungssysteme (Schweiz) AG 8201 Schaffhausen Phone +41(0)52 631 30 26 ch.ps@georgfischer.com www.piping.georgfischer.ch
Austria Georg Fischer Rohrleitungssysteme GmbH 3130 Herzogenburg Phone +43(0)2782 856 43-0 austria.ps@georgfischer.com www.georgfischer.at	France Georg Fischer SAS 95932 Roissy Charles de Gaulle Cedex Phone +33(0)1 41 84 68 84 fr.ps@georgfischer.com www.georgfischer.fr	Korea Georg Fischer Piping Systems Guro-3 dong, Guro-gu, Seoul, Korea Phone +82(0)2 2081 1450 Fax +82(0)2 2081 1453 kor.ps@georgfischer.com	Poland Georg Fischer Sp. z o.o. 02-226 Warszawa Phone +48(0)22 313 10 50 poland.ps@georgfischer.com www.georgfischer.pl	Taiwan Georg Fischer Piping Systems San Chung City, Taipei Hsien Phone +886 2 8512 2822 Ext. 15 Fax +886 2 8512 2823
Germany Georg Fischer Fittings GmbH 3160 Traisen Phone +43 (0)2762 90300 fittings.ps@georgfischer.com www.fittings.at	Germany Georg Fischer GmbH 73095 Albershausen Phone +49(0)7161 302-0 info.de.ps@georgfischer.com www.georgfischer.de	Malaysia Georg Fischer (M) Sdn. Bhd. 40460 Shah Alam, Selangor Phone +60 (0)3 5122 5585 conne.kong@georgfischer.com	Romania Georg Fischer Piping Systems Ltd 020257 Bucharest - Sector 2 Phone +40(0)21 230 53 80 ro.ps@georgfischer.com	United Kingdom/Ireland Georg Fischer Sales Limited Coventry, CV2 2ST Phone +44(0)2476 535 535 uk.ps@georgfischer.com www.georgfischer.co.uk
Belgium/Luxembourg Georg Fischer NV/SA 1070 Bruxelles/Brüssel Phone +32(0)2 556 40 20 be.ps@georgfischer.com www.georgfischer.be	India Georg Fischer Piping Systems Ltd 400 076 Mumbai Phone +91 224007 2001 in.ps@georgfischer.com www.georgfischer.in	Mexico Georg Fischer S.A. de C.V. Apodaca, Nuevo Leon CP66636 Mexico Phone +52 (81)1340 8586 Fax +52 (81)1522 8906	Russia Georg Fischer Piping Systems Moscow 125047 Tel. +7 495 258 60 80 ru.ps@georgfischer.com	USA/Canada/Latin America/Caribbean Georg Fischer LLC Tustin, CA 92780-7258 Phone +1(714) 731 88 00 Toll Free 800/854 40 90 us.ps@georgfischer.com www.us.piping.georgfischer.com
Brazil Georg Fischer Ltda 04795-100 São Paulo Phone +55(0)11 5687 1311 br.ps@georgfischer.com	Italy Georg Fischer S.p.A. 20063 Cernusco S/N (MI) Phone +3902 921 861 it.ps@georgfischer.com www.georgfischer.it	Middle East Georg Fischer Piping Systems Dubai, United Arab Emirates Phone +971 4 289 41 20 gfdubai@emirates.net.ae www.piping.georgfischer.com	Singapore Georg Fischer Pte Ltd 528 872 Singapore Phone +65(0)67 47 06 11 sgp.ps@georgfischer.com www.georgfischer.com.sg	Export Georg Fischer Piping Systems (Switzerland) Ltd. 8201 Schaffhausen Phone +41(0)52 631 30 03 Fax +41(0)52 631 28 93 info.export@georgfischer.com www.piping.georgfischer.ch
China Georg Fischer Piping Systems Ltd Shanghai Pudong, Shanghai 201319 Phone +86(0)21 58 13 33 33 china.ps@georgfischer.com www.cn.piping.georgfischer.com	Georg Fischer TPA Srl Via Bonazzi, 32 IT-40013 Castel Maggiore (BO) Phone +39 051 632 42 11 tpa.ps@georgfischer.com www.alprene.com	Netherlands Georg Fischer N.V. 8161 PA Epe Phone +31(0)578 678 222 nl.ps@georgfischer.com www.georgfischer.nl	Spain/Portugal Georg Fischer S.A. 280046 Madrid Phone +34(0)91 781 98 90 es.ps@georgfischer.com www.georgfischer.es	
		NL-8160 AG Epe Phone +31 (0)578 678 378 waga.ps@georgfischer.com www.waga.nl	Sweden/Finland Georg Fischer AB 12523 Älvsjö-Stockholm Phone +46(0)8 506 775 00 info.se.ps@georgfischer.com www.georgfischer.se	