

Quantometer MZ

MZ meters are flow meters. The flow of gas turns the turbine wheel, and thus the rotating speed of the turbine is proportional to the linear speed of the gas.

The movement is mechanically transmitted to the totaliser through a magnetic coupling.

Description

The MZ meter is composed of five 5 main parts:

- > a body part containing all the components (1)
- > a flow straightener to stabilise and accelerate the flow before the turbine wheel (2)
- > a measuring unit including the turbine wheel (3)
- > a magnetic coupling to transmit the movement of the turbine wheel to the totaliser (4)
- > a totaliser to register the measured gas (5)

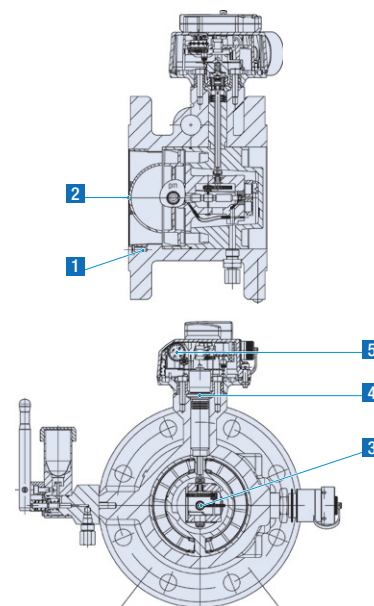

Applications

MZ meters are designed to measure natural gas, and various filtered, and non-corrosive gases.

They are used to measure low to medium and high flow, at low or medium, or high pressure.

They have been especially designed for industrial use and for secondary measurement.

The possibility of fitting various options such as the oil pump or the PTFE coating version, means that they are also suitable for use in heavy duty measurement.

Features

Intrinsic safety approval	L.C.I.E. 06 ATEX 6031 X
Flow rate	From 6 m ³ /h to 10000 m ³ /h
Nominal diameters	From DN 2" to 16", 50 to 400 mm
Material	Ductile iron, cast steel or welded steel. Compliant with the Pressure Equipment Directive 97/23/EC
Maximum working pressure	Up to 100 bar depending on the body material and flanging.
Temperature range	Ambient: -30°C to +60°C Gas: -30°C to +60°C Storing temperature: -40°C to +70°C
Metrology	The tolerance of acceptance is +/-1.5% from Qmin to Qmax.

Typical calibration curve

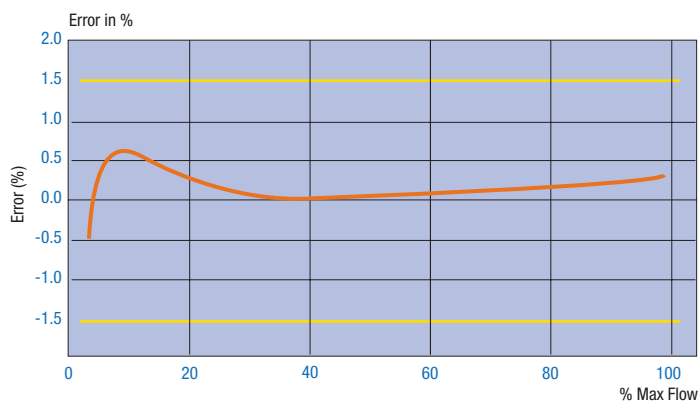

- > High accuracy budget meter
- > Flow rate up to 10000 m³/h
- > Pressure range up to 100 bar
- > Equipped as standard with the cycle target.
- > Various options available:
Low and high frequency transmitters,
thermowell, oil pump, version for aggressive gases, etc.

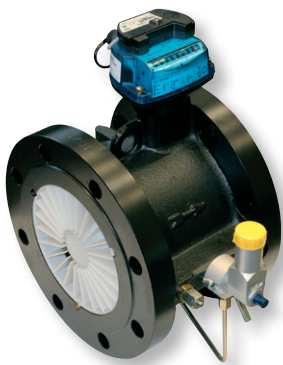

> Quantometer MZ DN150, Qmax: 1600 m³/h

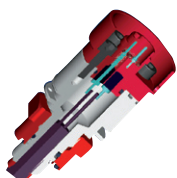
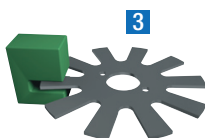
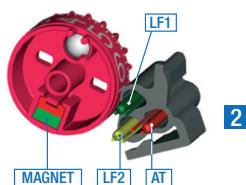

Totaliser:

- 9-digit index to register a larger volume
- 45° orientation for an easy reading
- Equipped as standard with the cyble target: it allows the installation of the cyble sensor at any time.
- Free-rotating totaliser
- Equipped with 1 built-in silicagel cartridge
- Fitted with a reflecting disc on the first drum.
- IP67 protection
- UV resistant cover
- Unit: m³



> Universal totaliser fitted as standard with the Cyble target

Transmitters

- 1 Cyble sensor: it can be delivered mounted onto the meter or installed afterwards at any time. The Cyble sensor is a bounce-free transmitter. It allows also the counting of eventual back flows.
- 2 Low Frequency (LF): two Reed switches are fitted as an option on the whole range. Anti-tampering (AT): this device is fitted as an option on the whole range.
- 3 Medium Frequency (MF): one transmitter is supplied as an option.
- 4 High Frequency (HF): a transmitter is supplied as an option on the whole range, and it is fitted close to the turbine wheel.

Oil pump

- 5 It lubricates the ball bearings in the measuring unit. The oiling can be done even when the meter is under pressure. The oil reservoir can be easily turned to fit with vertical installed meters.

Turbine wheel

- 6 This is the most important component of the meter for achieving high accuracy at low and high pressure. It can be made in aluminium for the whole range or in polyacetal for the DN≤200. Depending on the maximum flow rate, the blade of turbine wheel is oriented at 45° or 60°. Turbine wheel at 60° is used to avoid over-speed of the wheel. When a HF is requested, the wheel must be in aluminium. For high pressure use, or for measuring dirty gases, an aluminium wheel is recommended.

Thermowell

- 7 A thermowell can be installed as an option into the meter. It allows the gas temperature to be measured at the reference point. (Installation of a thermowell cannot be done into a meter equipped with HF transmitter)

Volume converter

- 8 It can be installed directly onto the meter thanks to a mounting kit

Pressure tapping:

This device allows the gas pressure to be measured at the reference point. It is installed as standard.

Measurement of aggressive gases:

A version with a PTFE (Teflon) coating, is available, as an option. The coating is applied on the internal parts of the meter.

Characteristics

A) Technical data sheet

Rangeability and pulse values

With correction gears 32/40 (correction 0%)										
DN (mm)	Max Flow (m ³ /h)	Min Flow (m ³ /h)	Pressure loss (mbar) $\rho = 0.8 \text{ kg/m}^3$	1 Imp LF & Cyble (m ³ /Imp)	Freq LF Qmax (Hz)	1 Imp MF (dm ³ /Imp)	Freq MF Qmax (Hz)	1 Imp HF (dm ³ /Imp)	Freq HF Qmax (Hz)	RPM Qmax (Rot/min)
50	100	6	8.1	0.1	0.28	5.8947	4.71	0.00970	2864	14322
80	160	10	2	1	0.04	23.07692	1.93	0.03797	1171	5853
	250	16	4.8		0.07	23.07692	3.01	0.03797	1829	9146
	400	25	11		0.11	39.11111	2.84	0.06434	1727	8634
100	250	16	2	1	0.07	23.07692	3.01	0.06271	1107	4153
	400	25	4.8		0.11	23.07692	4.81	0.06271	1772	6644
	650	40	11		0.18	39.11111	4.62	0.10628	1699	6371
150	650	40	1.5	1	0.18	23.07692	7.82	0.15385	1174	3521
	1000	65	4.3		0.28	23.07692	12.04	0.15385	1806	5417
	1600	100	9		0.44	39.11111	11.36	0.26074	1705	5114
200	1000	65	1.5	10	0.03	230.7692	1.2	0.37661	738	2213
	1600	100	4.3		0.04	230.7692	1.93	0.37661	1180	3540
	2500	160	9		0.07	391.1111	1.78	0.63829	1088	3264
250	1600	100	1.5	10	0.04	230.7692	1.93	0.5787	768	1920
	2500	160	4.3		0.07	230.7692	3.01	0.5787	1200	3000
	4000	250	9		0.11	391.1111	2.84	0.9808	1133	2832
300	2500	160	1.5	10	0.07	218.1818	3.18	0.85763	810	1735
	4000	250	4.3		0.11	218.1818	5.09	0.85763	1296	2776
	6500	400	9		0.18	391.1111	4.62	1.53739	1174	2517
400	4000	250	1.5	10	0.11	218.1818	5.09	2.04673	543	1163
	6500	400	4.3		0.18	218.1818	8.28	2.04673	882	1890
	10000	650	9		0.28	391.1111	7.1	3.66896	757	1622

Body construction

DN (mm)	ISO PN 10	ISO PN 16	ISO PN 25	ISO PN 40	ISO PN 20 ANSI 150	ISO PN 50 ANSI 300	PN 110 ANSI 600
50	A	A	A	A	A	-	-
80	A	A	A	A	A	C	C
100	B	B	B	B	B	C	C
150	B	B	B	B	B	C	C
200	B	B	C	C	B	C	C
250	D	D	D	D	D	D	D
300	D	D	D	D	D	D	D
400	D	D	D	D	D	D	D

A: EN-GJS-400-18LT Sandwich body

B: EN-GJS-400-18LT flanges body

C: Steel Sandwich body

D: Steel flanges body (cast or welded)

Note: for the pressure and temperature range of the body material, please check your National Rules

B) Calculation of the extended rangeability

When the density of the measured gas increases, the minimum measured flow rate decreases.

This minimum flow rate in real conditions (Q_{minRC}) can be evaluated using the following formula:

Q_{min1,2}: minimum flowrate (m³/h) for a density of 1.2 kg/m³

ρ_{RC} : density of the gas in real conditions (kg/m³)

$$Q_{minRC} = Q_{min1,2} \times \sqrt{\frac{1.2}{\rho_{RC}}}$$

C) Pressure loss of the MZ meters Values: see table above

Calculation of pressure loss: $\Delta p = \Delta p_r \times \frac{\rho n}{0.83} \times (P_b + 1) \times \left[\frac{q}{Q_{max}} \right]^2 \times \left[\frac{273}{(273 + T_b)} \right]$

> Where:

Δp : Pressure loss in the calculated conditions

Δp_r : Pressure loss in the reference conditions

ρn : Gas density (kg/m³) at 0° C and 1013 mbar

P_b : Operating pressure (Bar gauge)

q : Flow rate (m³/h)

Q_{max} : Maximum flow rate (m³/h)

T_b : Gas temperature (°C).

D) Dimensions (mm) and weights

DN	L	A	B	ISO PN 10 - ISO PN 40 ANSI 150				ISO PN 50 - ISO PN 110 ANSI 300 / ANSI 600			
				C	D	E	Kg	C	D	E	Kg
50	60	15	18	156	160	163	4	-	-	-	-
80	120	35	34	173	180	176	10	165	180	176	32
100	150	54	28	209	180	186	19	186	190	195	47
150	200	71	48	238	225	216	33	221	230	230	78
200	200	69	43	273	250	277	85	252	265	261	120
250	300	89	90	287	292	275	100	376	284	275	140
300	300	78	97	289	320	306	125	403	350	388	185
400	400	132	120	360	326	356	220	360	383	356	310

E) Transmitter characteristics

Intrinsic safety approval: L.C.I.E. 06 ATEX 6031 X
Intrinsic safety level:  II 1/2 G Ex ia IIC T5 c T6

Low Frequency pulse transmitter (LF):

The LF transmitter consists of 2 dry Reed switches, normally open, and controlled by a magnet situated in the first drum of the totaliser. The LF connections are without polarity.

Characteristics of LF transmitter:

- > Hermetically sealed contacts
- > Maximum terminal voltage:
30 Volt and maximum current according to EN 60079-11.
- > Maximum temperature: +60°C
- > Minimum pulse time: 0.4 sec
- > Cyble sensor: It conforms to CENELEC standard EN 60079-11 with:
 - $U_i \leq 14.3$ Volt
 - $i_i \leq 50$ mA

Anti-tampering transmitter (AT):

This consists of one dry Reed switch, normally closed. Attempts at magnetic tampering will open the contact. The electrical characteristics are the same as those for the LF transmitter.

F) Installation

Each meter is delivered with binder plugs for the installed transmitters and oil when an oil pump is installed. Please refer to the instruction manual supplied with the meter.

The advice given therein will ensure optimal use of the MZ quantometer over the years.

Inductive transmitters (MF and HF):

They are inductive sensors actuated by a toothed disc. The frequency is proportional to the instantaneous flow. The polarity of the connections is indicated on the name plate of the meter.

Characteristics of MF and HF transmitters:

- > Proximity detector conform to EN 60947-5-6 (NAMUR) standards
- > They conform to CENELEC standards (EN 60079-0 and EN 60079-11) with:
 - $U_i \leq 16$ Volt
 - $i_i \leq 52$ mA
 - $C_i \leq 50$ nF
 - $L_i \leq 250$ µH
 - $P_i \leq 64$ mW
- > Maximum temperature: + 60°C

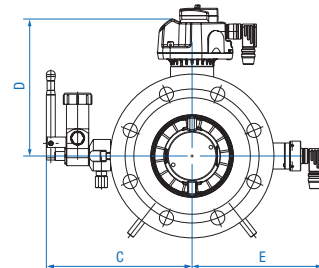
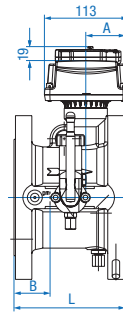

About Itron Inc.

Itron Inc. is a leading technology provider to the global energy and water industries. Our company is the world's leading provider of metering, data collection and utility software solutions, with nearly 8,000 utilities worldwide relying on our technology to optimize the delivery and use of energy and water. Our products include electricity, gas and water meters, data collection and communication systems, including automated meter reading (AMR) and advanced metering infrastructure (AMI); meter data management and related software applications; as well as project management, installation, and consulting services. To know more, start here: www.itron.com

For more information, contact your local sales representative or agency.

Itron

Itron GmbH.

Hardeckstraße 2
D-76185 Karlsruhe
Germany
Phone: +49-721 5981 0
Fax: +49-721 5981 189
www.itron.com